



ASSEMBLY INSTRUCTION

ITEM NO: B2008TF-1 TWIN LOFT BED



PARTS IDENTIFICATION

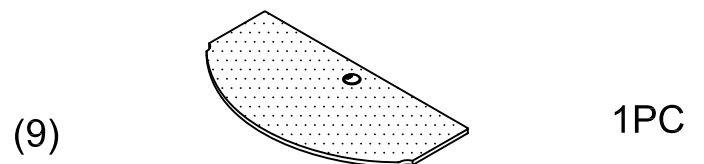
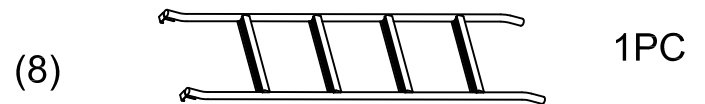
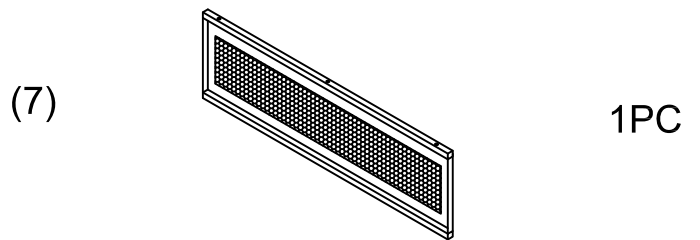
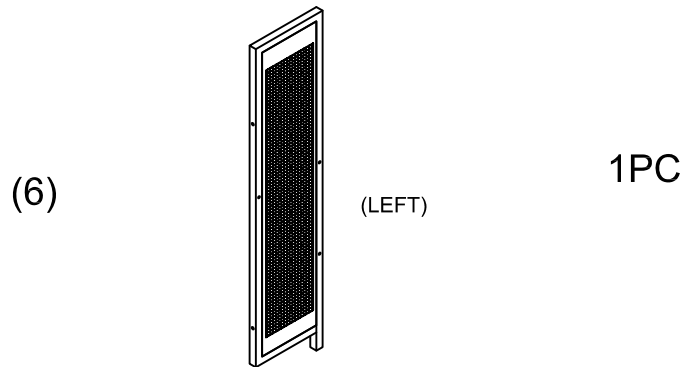
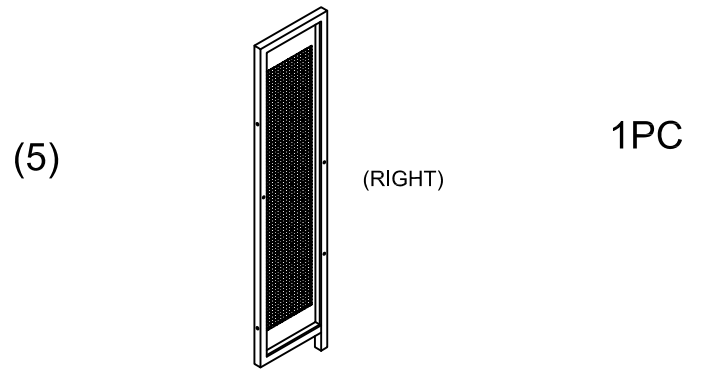
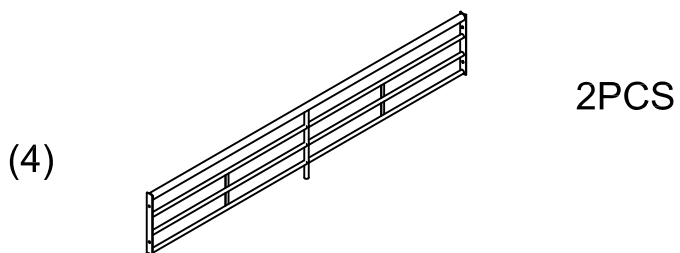
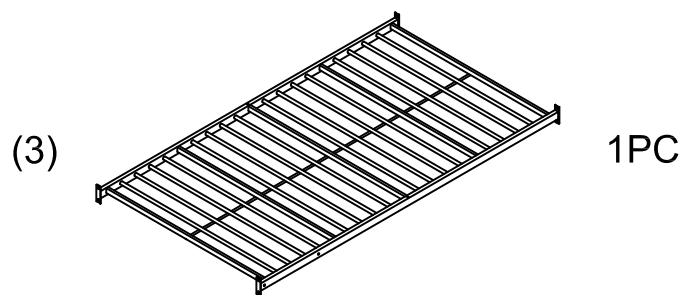
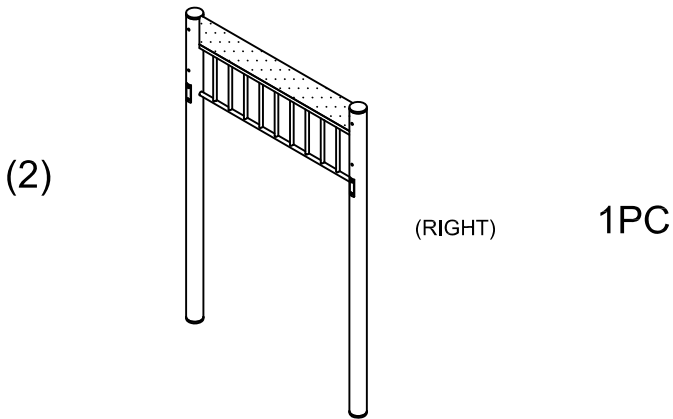
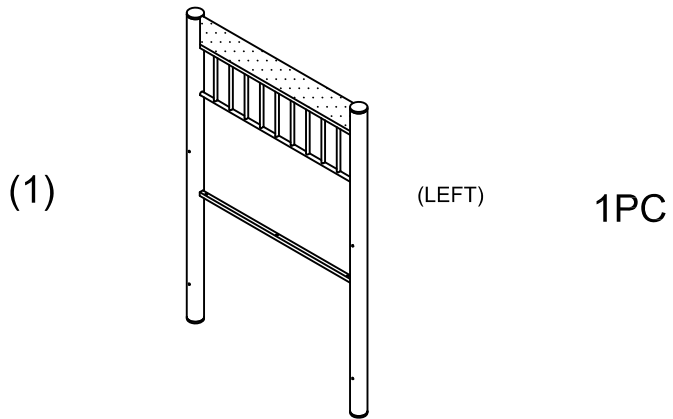

HARDWARE LIST

A		5/16"x2 $\frac{1}{4}$ " BOLT	2PCS
B		5/16"x1 $\frac{1}{4}$ " BOLT	2PCS
C		5/16"x3/4" BOLT	8PCS
D		1/4"x3 $\frac{3}{4}$ " BOLT	4PCS
E		1/4"x1 $\frac{3}{4}$ " BOLT	4PCS
F		1/4"x1 $\frac{1}{4}$ " BOLT	6PCS
G		1/4"x3/4" BOLT	8PCS
H		Ø 18xØ 9x1.0mm	12PCS
I		Ø 16xØ 7x1.0mm	18PCS
J		4mm	1PC
K		5mm	1PC

STEP1.

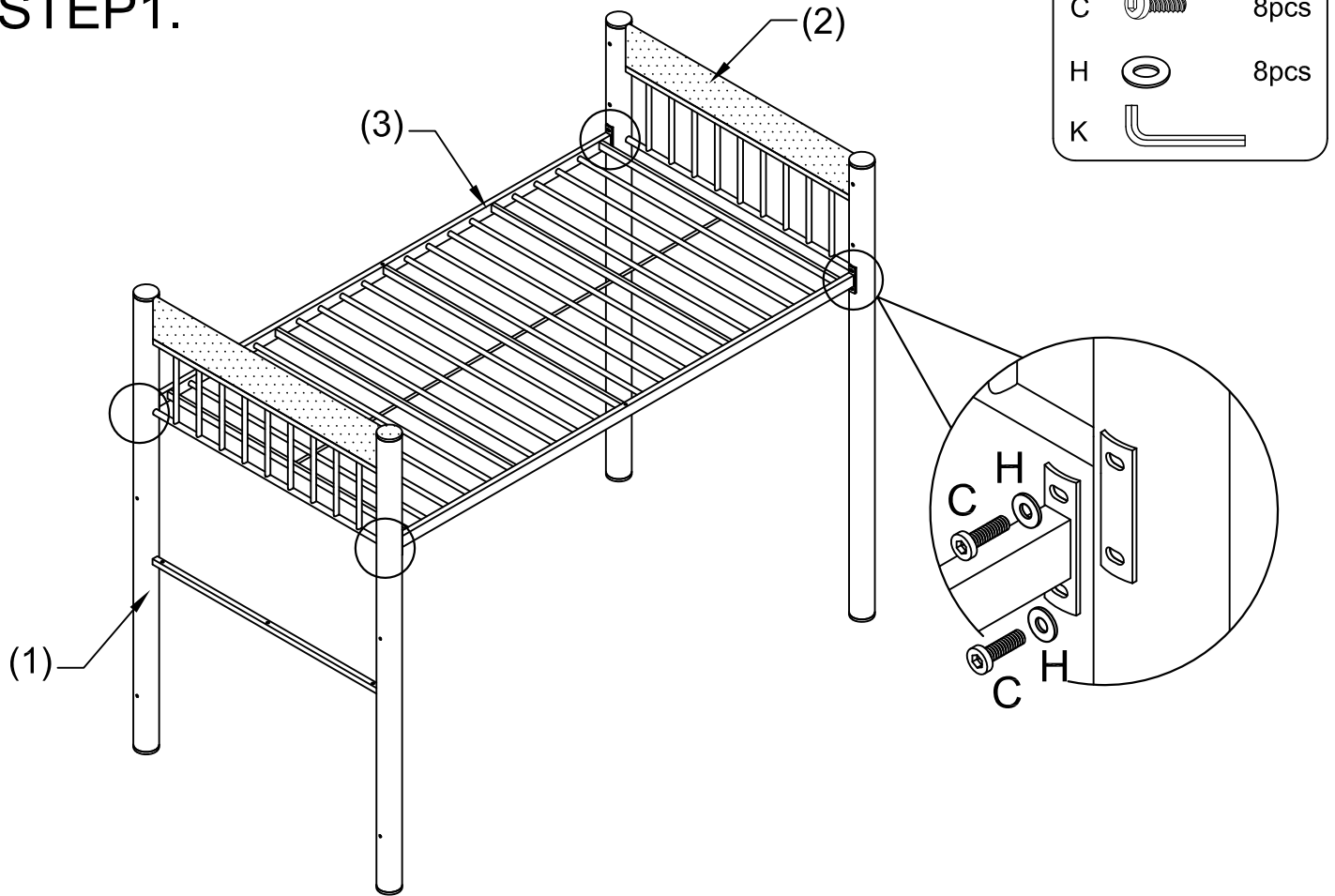

STEP2.

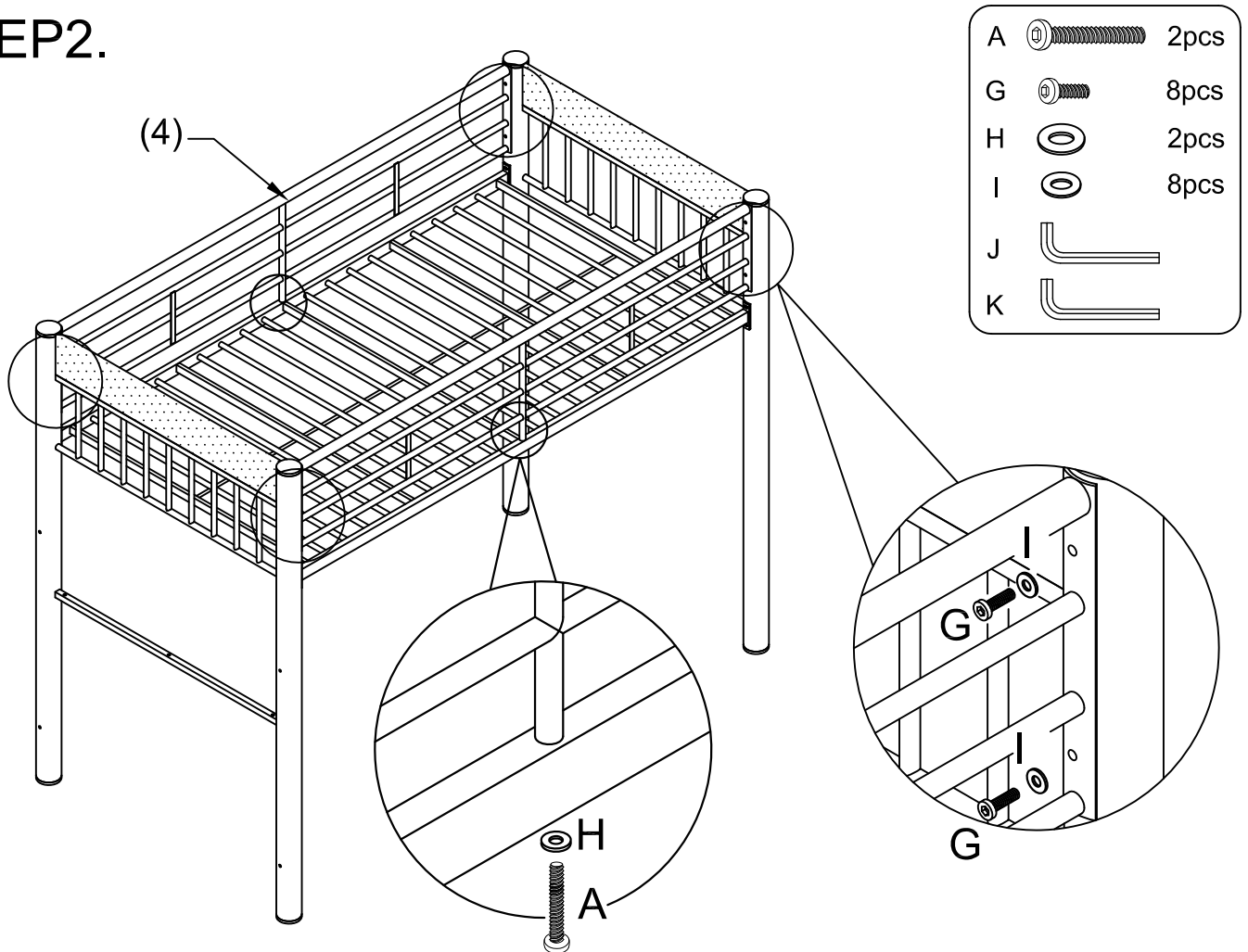

STEP3.

D  4pcs

J 

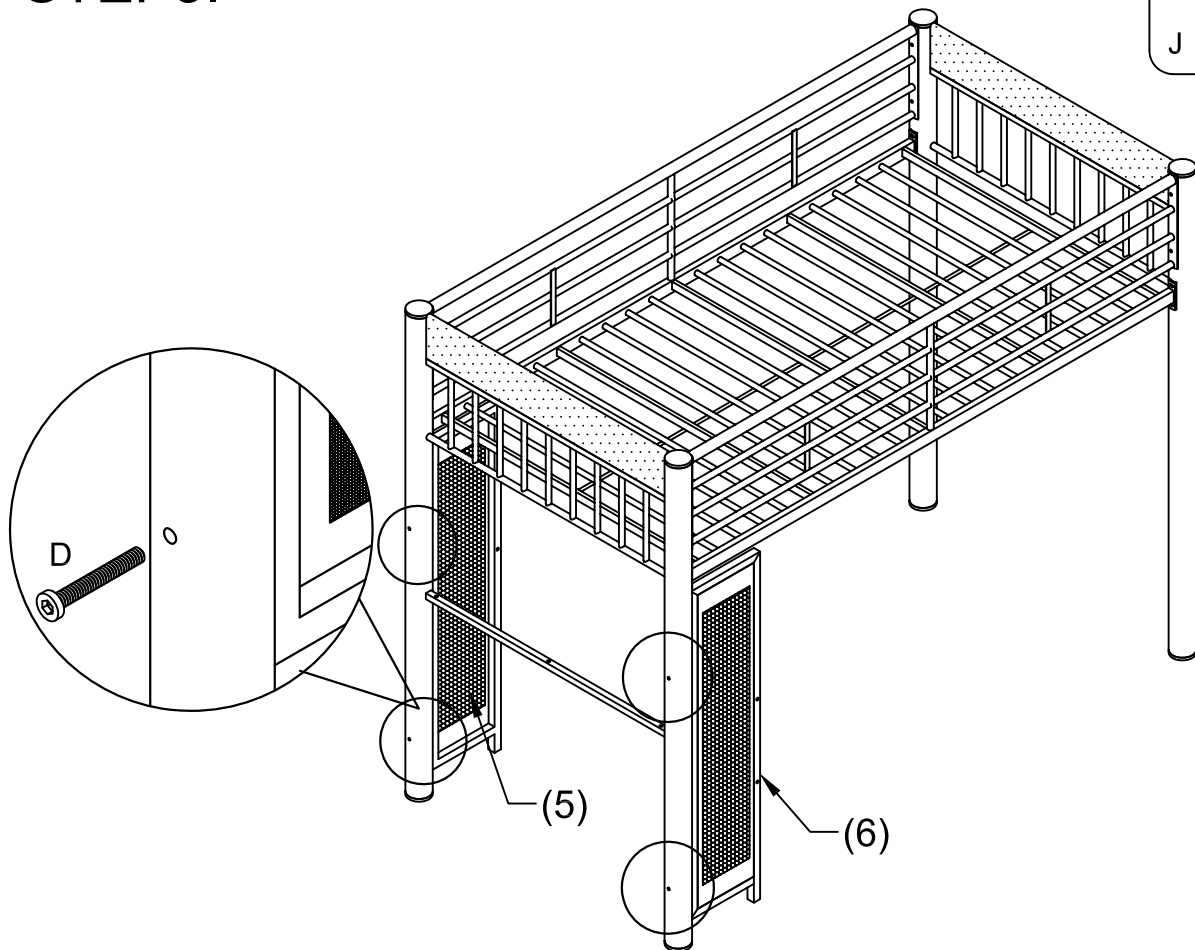

STEP4.



E  4pcs

I  4pcs

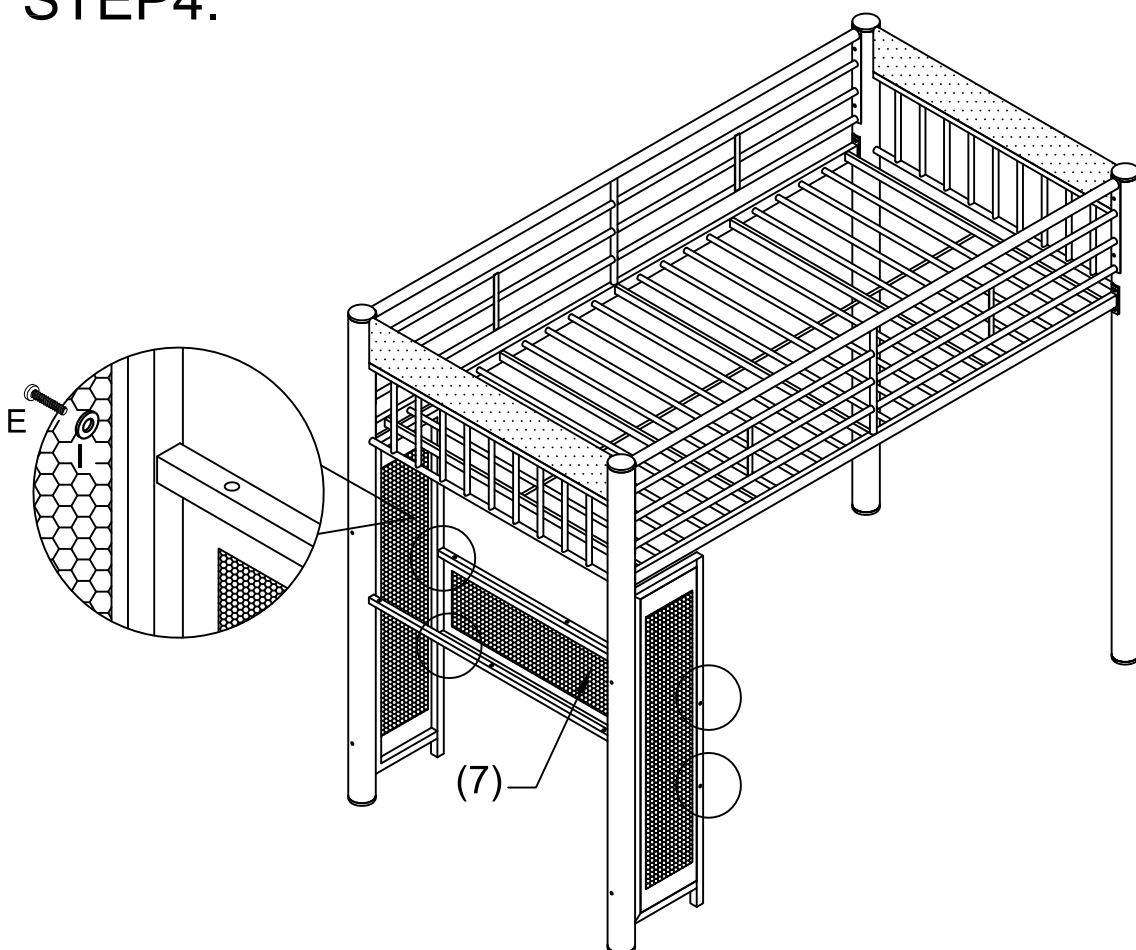
J 



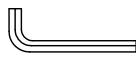

STEP5.

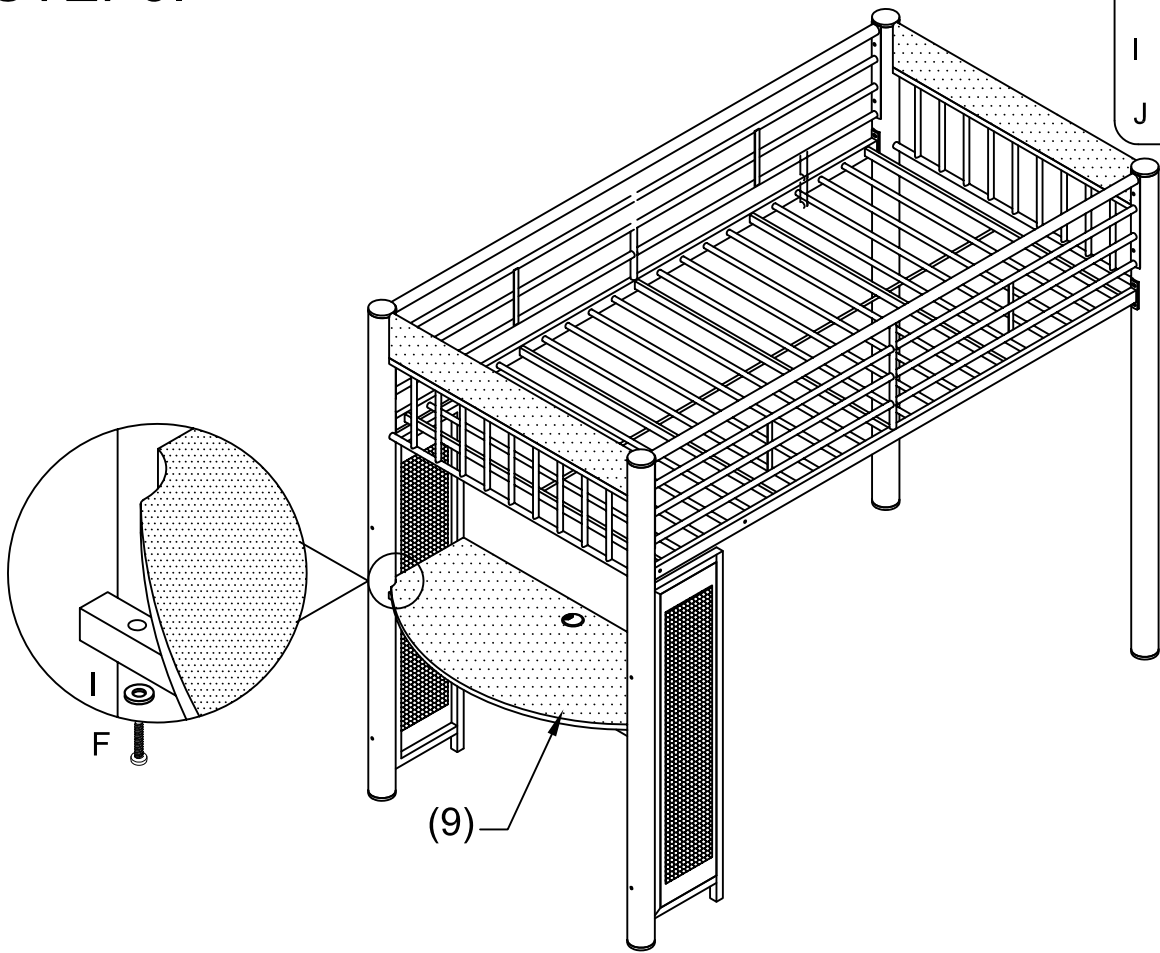
- F  6pcs
- I  6pcs
- J 



STEP6.

- B  2pcs
- H  2pcs
- K 

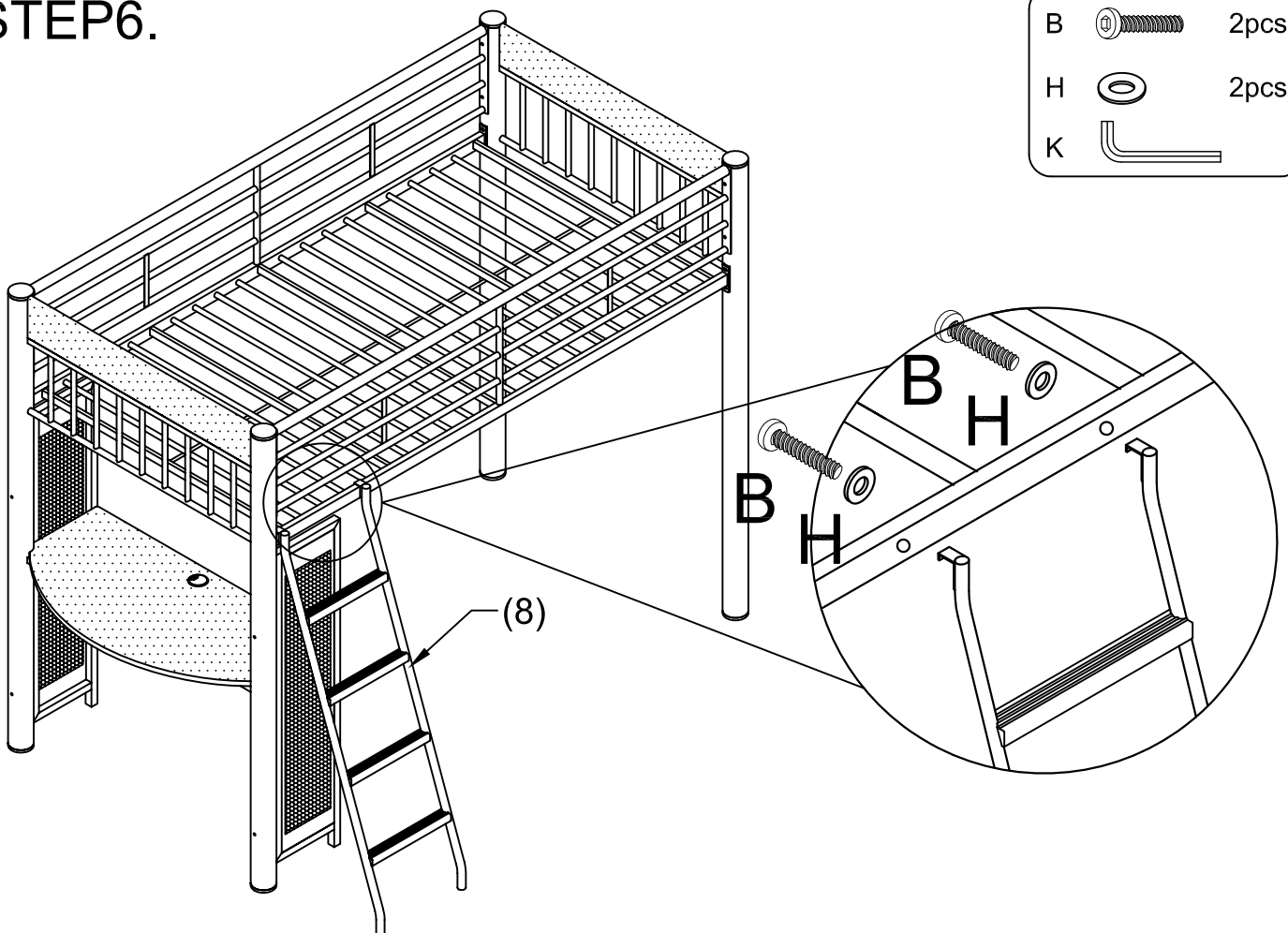

Safety Warnings

1. Follow the information on the warnings appearing on the upper bunk end structure and on the carton . Do not remove warning label from bed.
2. Always use the recommended size mattress or mattress support, or both, to help prevent the likelihood of entrapment or falls.
3. Surface of mattress must be at least 5 in(127mm). below the upper edge of guardrails .
4. Do not allow children under 6 years of age to use the upper bunk.
5. Periodically check and ensure that the guardrail, ladder ,and other components are in the proper position ,free from damage ,and that all connectors are tight .
6. Do not allow horseplay on or under the bed and prohibit jumping on the bed.
7. Always use the ladder for entering and leaving the upper bunk.
8. Do not use substitute parts ,Contact manufacturer or dealer for replacement parts.
9. Use of a night light may provide added safety precaution for a child using the upper bunk.
10. Always use guardrails on both long sides of the upper bunk.
If the bunk bed will be placed next to the wall, the guardrail that runs the full length of the bed should be placed against the wall to prevent entrapment between the bed and the wall.
11. The use of water or sleep flotation mattress is prohibited .
12. Keep these instructions for future reference.
13. Use only mattress which is (74"-75")X(37 $\frac{1}{2}$ "-38 $\frac{1}{2}$ ")X6" on upper bunk
14. Prohibit more than one person on upper bunk.
15. Maximum total weight is not to exceed 400 lbs.on the upper bunk.

STRANGULATION HAZARD:

Never attach or hang items to any part of the bunk bed that are not designed for use with the bed,for example, but not limited to, hooks, belts, and jump ropes.