

SEVILLE ASSEMBLY INSTRUCTION

**MODEL 0194B :
DRESSER & MIRROR**

(Box 1)

BOX OF MIRROR

NO	ITEM	Qty
A	MIRROR	1 PC
B	MIRROR SUPPORT RAIL	2 PCS

(Box. 2)

BOX OF DRESSER

NO	ITEM	Qty
C	DRESSER	1 PC

STEP 1

Draw out mirror support (B) from the carton box.

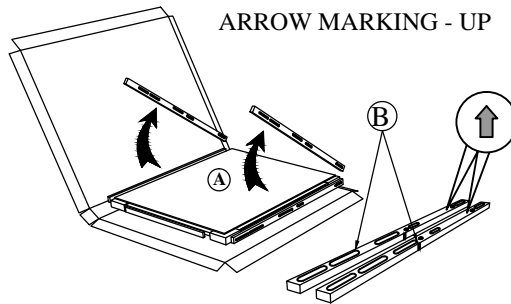

STEP 2 : Align & fasten mirror support (B) to the back of mirror (A) using short JCBC bolt(1),spring washer (3) & flat washer (4). **DO NOT FULLY TIGHTEN AT THIS STEP.**

Note : Make sure arrow marking of the mirror support (B) is aligned up.

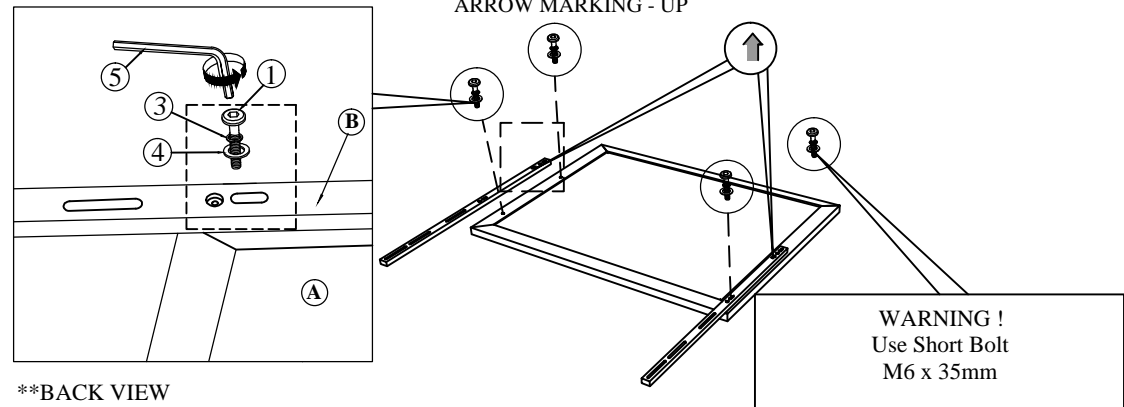

**BACK VIEW

STEP 3 : Place mirror (A) on top of dresser (C). Align & fasten mirror support (B) to the back of dresser (C) using long JCBC bolt (2) , spring washer (3) & flat washer (4) **THEN FULLY TIGHTEN ALL THE BOLTS AT STEP 2 & 3 WITH ALLEN KEY (5).**

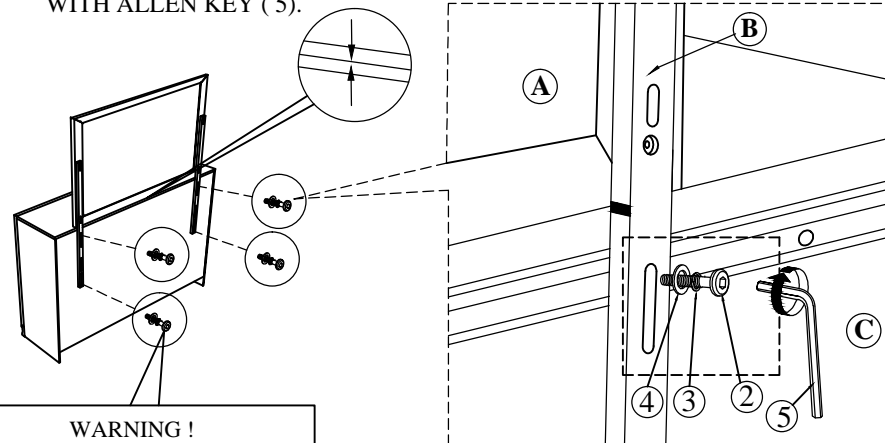

WARNING !
Use Long Bolt
M6 x 40mm

Note : Make sure arrow marking of the mirror support is aligned with the arrow marking of the center of the dresser as show in drawing.

**HARDWARE SET IS IN 1857-6 FOR ASSEMBLY

**(Box. 1)
HARDWARE LIST**

NO	ITEM	Qty
1	JCBC BOLT M6 x 35MM BLK	4 PCS
2	JCBC BOLT M6 x 40MM BLK	4 PCS
3	SPRING WASHER 1/4" RBW	8 PCS
4	FLAT WASHER 1/4" ID x 19mmOD BLK	8 PCS
5	ALLEN KEY m4 x 65mm BLK	1 PC



COMPLETED ASSEMBLY

NOTE : MUST TIGHTEN SCREWS PERIODCALLY WITH USE SCREW WILL BECOME LOOSE CHECK TIGHTNESS OF ALL SCREW EVERY 6-8 WEEKS.