

ASSEMBLY INSTRUCTIONS

MODEL : 0211A
NIGHT STAND

STEP 1 : Remove HANDLE (2) using a Philips head screw driver as shown in illustration STEP - A. Re-install the HANDLE (2) as per diagram STEP - B. Repeat STEP - A STEP - B until HANDLE (2) are attached correctly.



(BOX 1)

BOX OF NIGHT STAND

NO	ITEM	QTY
NIGHT STAND		
A		1 PC

(BOX 1)

HARDWARE LIST

NO	ITEM	QTY
1	Three Head Machine Screw 4x10mm Dia 	2 PCS
2	HANDLE 	2 PCS

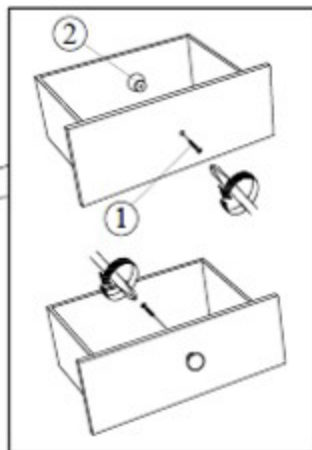
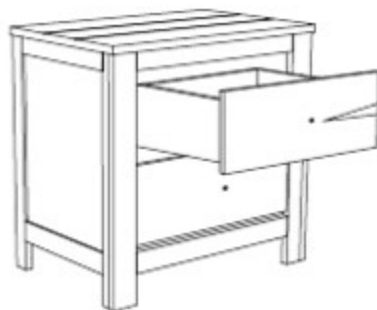

STEP - A

STEP - B



COMPLETED ASSEMBLY

NOTE : MUST TIGHTEN SCREWS **PERIODICALLY** WITH USE SCREW WILL BECOME LOOSE CHECK TIGHTNESS OF ALL SCREW EVERY 6-8 WEEKS.