







# ASSEMBLY INSTRUCTIONS





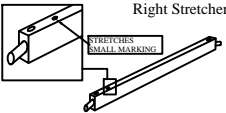
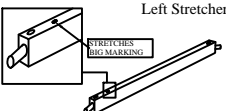

**MODEL : 9025B**  
**MONACO BAR STOOL CHAIR**  
**(Box 1)**

BOX OF BARSTOOL (X2)

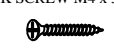
| No | ITEM   | Qty  |
|----|--|------|
| A  | Back Rest<br>                               | 1 pc |
| B  | Right Front Leg with small hole marking<br> | 1 pc |
| C  | Left Front Leg<br>                          | 1 pc |
| D  | Cushion Seat<br>                            | 1 pc |
| E  | Right Stretcher<br>                         | 1 pc |
| F  | Left Stretcher<br>                          | 1 pc |
| G  | Front Stretcher<br>                         | 1 pc |

(Box 1)

HARDWARE LIST(X2)

| No | ITEM   | Qty    |
|----|--|--------|
| 1  | CSK SCREW M4 x 35MM<br>     | 6 pcs  |
| 2  | JCBB BOLT M8 x 50MM<br>     | 4 pcs  |
| 3  | JCBB BOLT M8 x 80MM<br>     | 4 pcs  |
| 4  | JCBB BOLT M8 x 40MM<br>     | 2 pcs  |
| 5  | SPRING WASHER M8 BLK<br>    | 10 pcs |
| 6  | FLAT WASHER M8 x 22 BLK<br> | 10 pcs |
| 7  | ALLEN KEY M5<br>            | 1 pc   |

**STEP 1 :** Remove chair leg from the box seat (D) by open the bottom seat cover as shown.

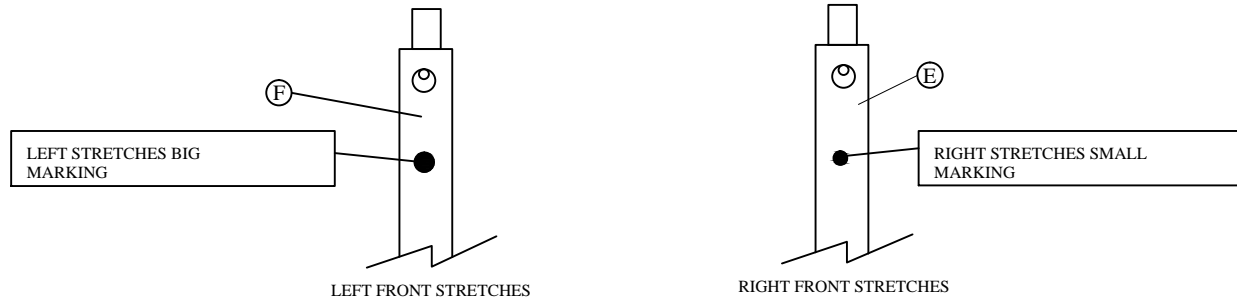

**STEP 2 :** Align the cushion seat (D) to the Back Rest (A) by secure with JCBB Bolt (3), Spring Washer (5) & flat washer (6) and tighten them with Allen Key (7) (DO NOT TIGHTEN BOLTS DURING THIS STEP)

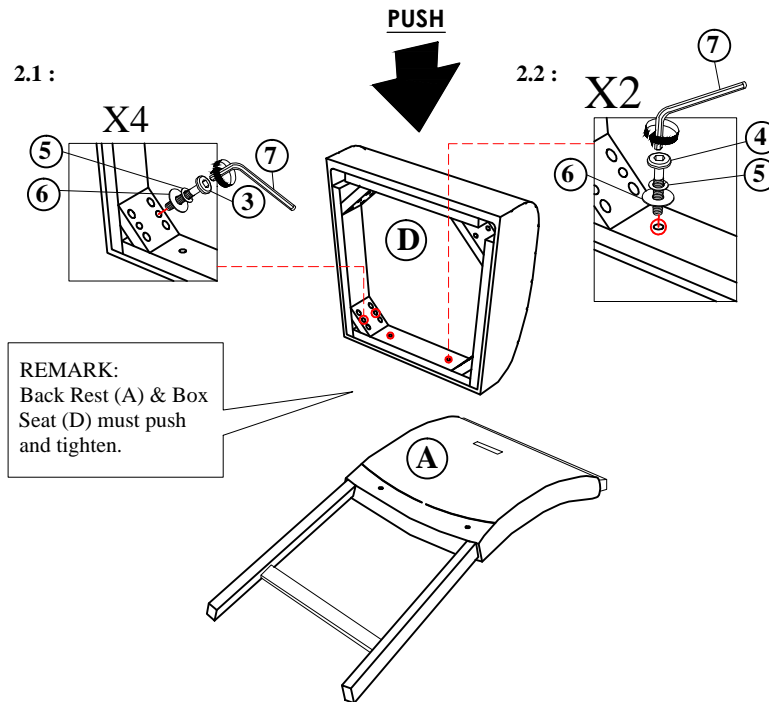

**STEP 3 :** Tighten the Right stretcher ( E ) and Left stretcher ( F ) with Csk Screw ( 1 ) and tighten with Screw Driver . ( Not Included )

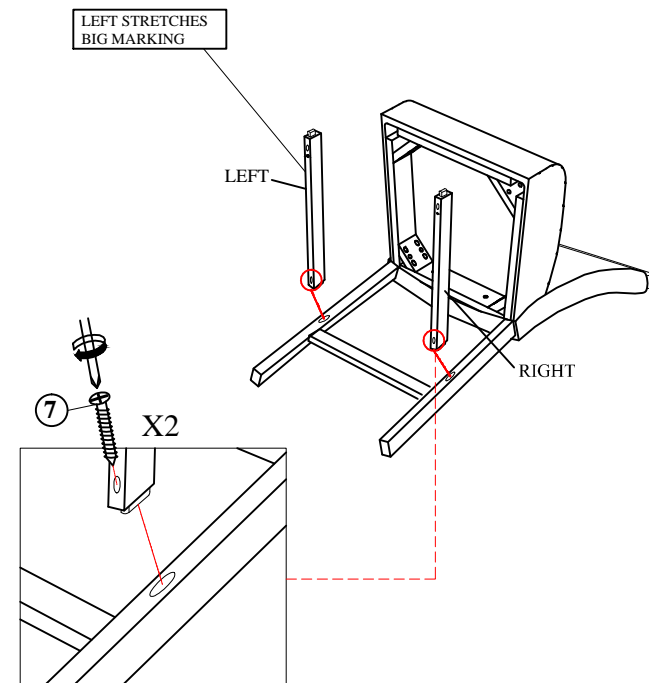

NOTE : MUST TIGHTEN SCREWS PERIODCALLY WITH USE SCREW WILL BECOME LOOSE CHECK TIGHTNESS OF ALL SCREW EVERY 6-8 WEEKS.

**STEP 4 : Fix Front Stretcher ( G ) to Front Leg Right ( B ) & Front Leg Left ( C ) with CSK Screw ( 1 ) and tighten with screw driver . (Not Included)**

**STEP 5 : Tighten the Right stretcher ( E ) and Left stretcher ( F ) with Csk Screw ( 1 ) and tighten with Screw Driver. ( Not Included )**

( Reminder : Make sure all legs stable on the floor surface before FULLY TIGHTEN all the screw. )

**STEP 6 : Fix Front Leg ( B ) & ( C ) to Cusion Seat ( D ) and Secure With JCBC Bolt ( 2 ), Spring Washer ( 5 ) & Flat Washer ( 6 ) and tighten them with Allen Key ( 7 ).**

( Reminder : Make sure all legs stable on the floor surface before FULLY TIGHTEN all the screw. )

STEP 4

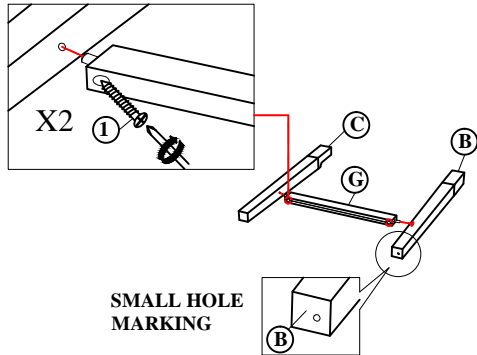

STEP 5

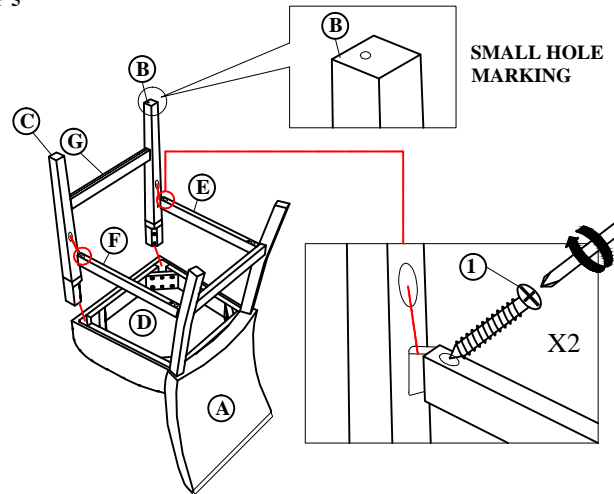

STEP 6

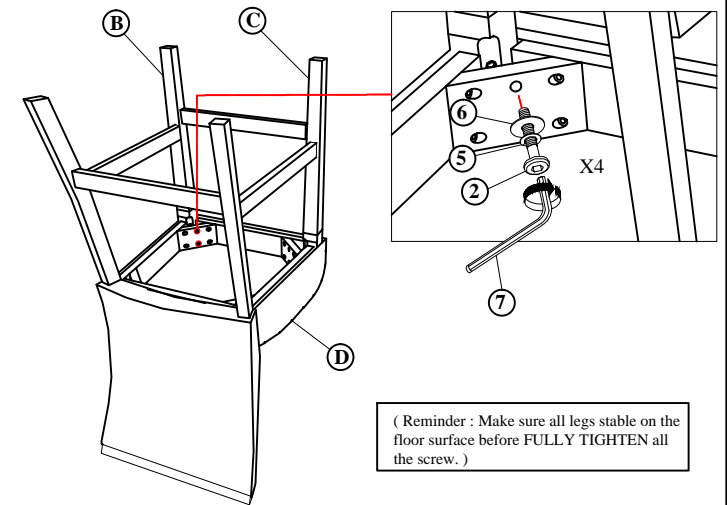

**STEP 7 : Closed down the cover of bottom cushion seat ( C ) after all parts completely fixed.**

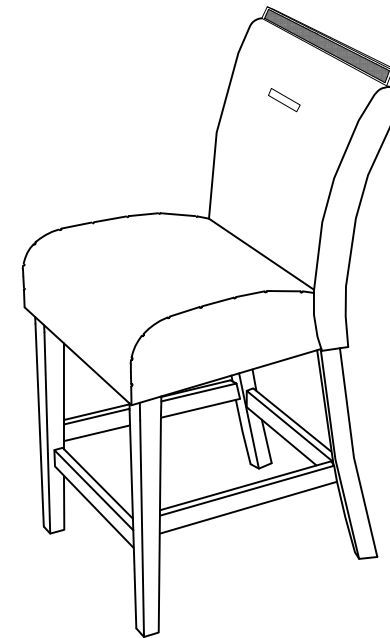
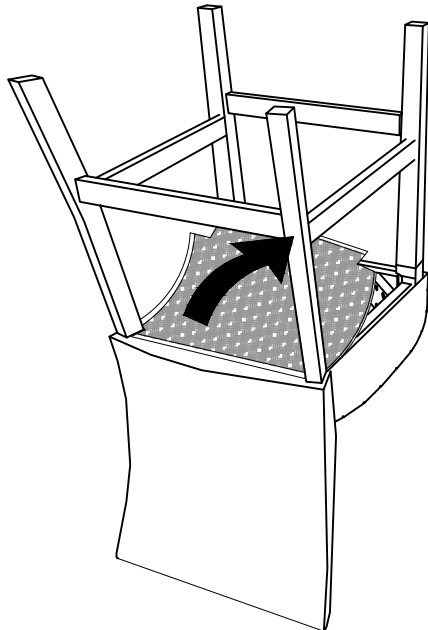

COMPLETE ASSEMBLY

**NOTE : MUST TIGHTEN SCREWS PERIODCALLY WITH USE SCREW WILL BECOME LOOSE CHECK TIGHTNESS OF ALL SCREW EVERY 6-8 WEEKS.**