

# ASSEMBLY INSTRUCTION

Model : D9002DC

Description : Dining chair

Thank you for purchasing this quality product. Be sure to check all packing material carefully for small parts that may have come loose inside the carton during shipment.

Step 1:

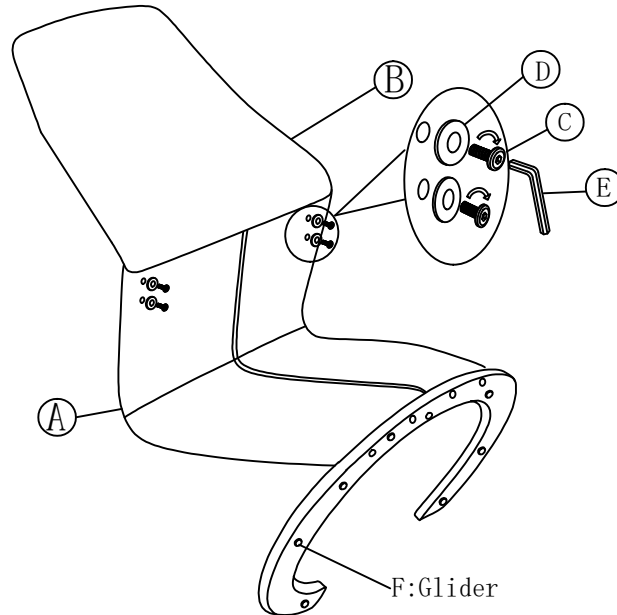

## PART LIST :

No.	Description	Diagram	Quantity
A	The cushion and frame		1
B	Back of a chair		1

## HARDWARE LIST :

No.	Description	Diagram	Size	Quantity
C	Bolt		M6 x 12mm	4
D	Flat washer		Ø16 x Ø6mm	4
E	Allen key		M4	1

## PREFIX HARDWARE:

F	Glider			8
---	--------	--	--	---

Step 2:

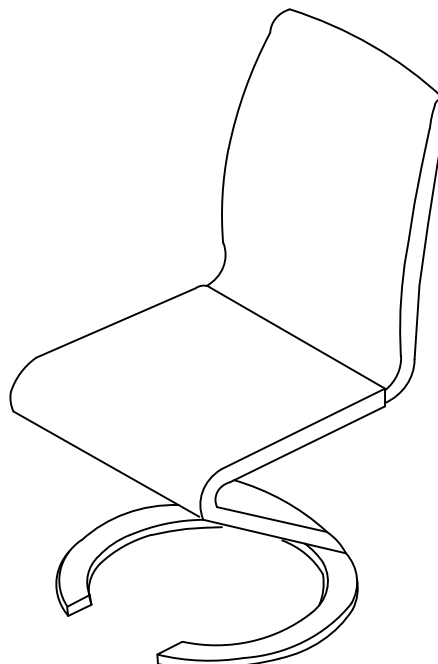

Poor Assembly Picture:

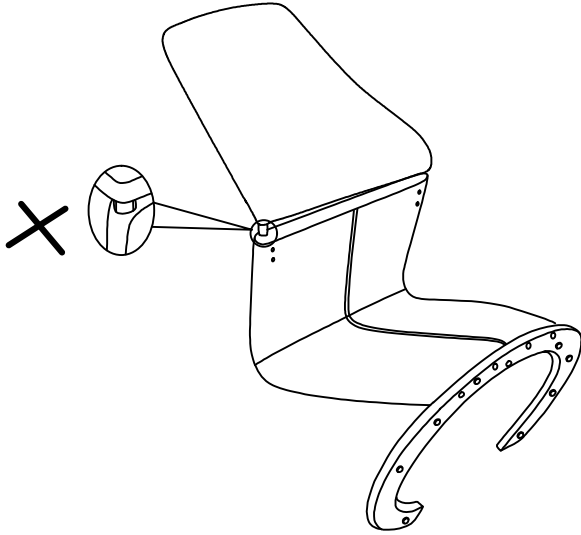

Step 2-a: Put the backrest (B) into the holes on the seat (A), press a little to make the screw holes on the backrest (B) align with the screw holes on the seat (A), lock these four holes with bolts (C). (Note: do not lock completely at this step)

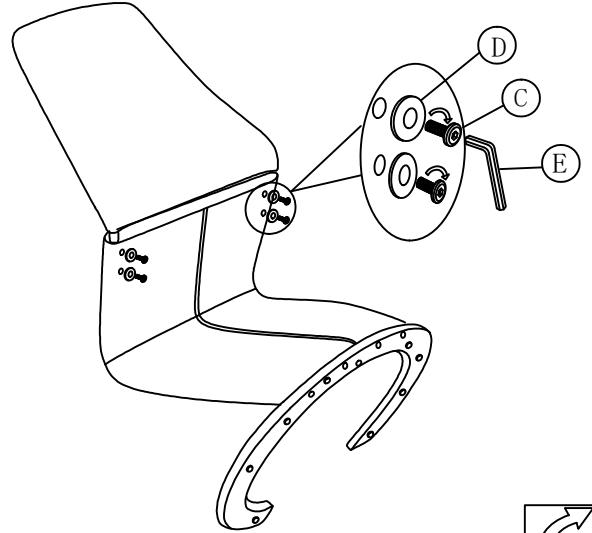

Step 2-b: Press the backrest (B) harder to make inner surface of the back close contact with the seat (A) and then 100% lock the four bolts (C). (Note: do not lock the screws when the back and cushion are at untight contact position like poor assembly picture)

Finished:

