

# Assembly Instructions

CM8372BK/WH-T

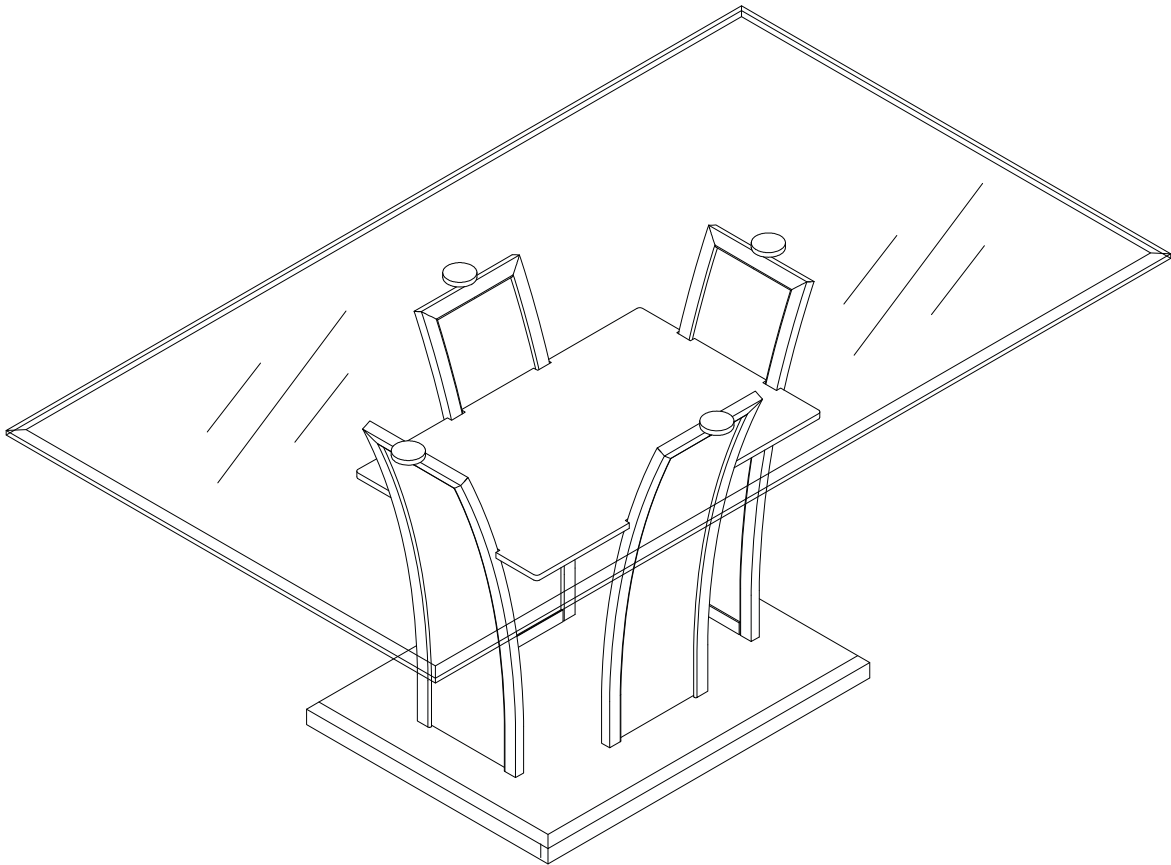

## ASSEMBLY RATING

The Assembly Rating is a 5-point system that shows the degree of effort needed in assembling a specific product (with 1 being easy and 5 being difficult). For some products, two persons are recommended.

EASY  DIFFICULT

## Tools Required For Assembly:

Allen Wrench

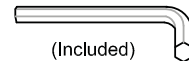

Phillips Screwdriver

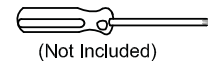

2 PERSONS RECOMMENDED

# ASSEMBLY & CARE ADVICE

FOR YOUR FURNITURE TO LAST, CORRECT ASSEMBLY AND PROPER MAINTENANCE ARE NECESSARY. PLEASE FOLLOW THE INFORMATION PROVIDED BELOW TO FULLY ENJOY YOUR FURNITURE.

## BASIC ASSEMBLY TECHNIQUES

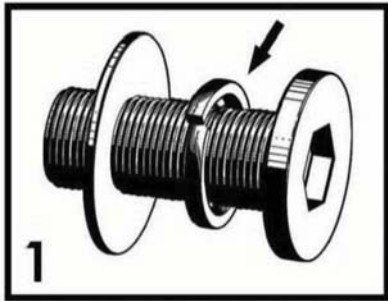

1 When lock or spring washer is used in an assembly, please make sure the lock or spring washer is placed between the larger flat washer and the head of the screw or bolt.

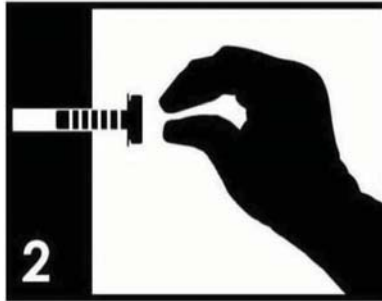

2 Position each part correctly and insert screws or bolts into their respective holes by hand tighten or using the proper hand tool. Only tighten when step is completed or when instructed to do so.

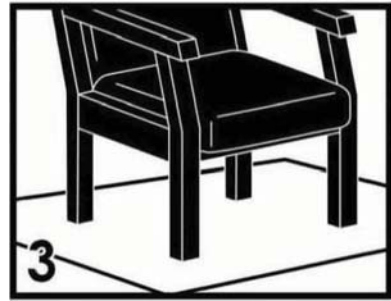

3 Use cardboard or carpet area when assembling furniture to prevent scratches. Make sure the furniture rests on a flat and level surface with each leg evenly touching the floor.

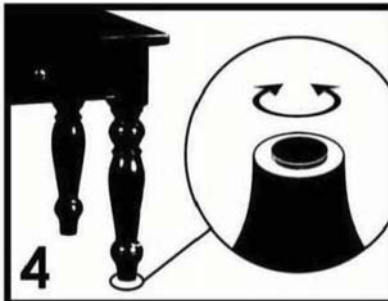

4 Some furniture comes with height adjustment knobs underneath each leg. To lower or to raise each leg, you need to turn clockwise or counterclockwise, respectively.

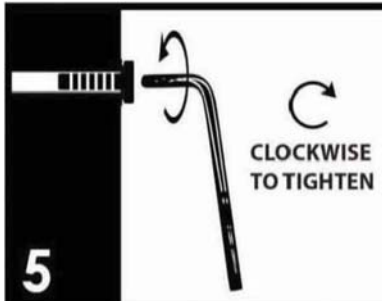

5 Make sure all parts are properly aligned, then use the appropriate hand tool to completely tighten the bolts or screws. Do not use power tools and do not overtighten.

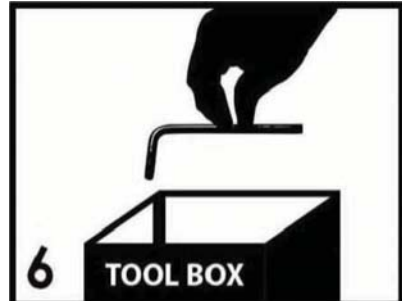

6 Save the instructions and store the Allen wrench or any supplied tool for later maintenance. After two weeks, check and tighten any loose hardware and repeat again every six months thereafter.

IT IS THE USER'S RESPONSIBILITY TO MAINTAIN THE FURNITURE. THE HARDWARE MAY LOOSEN OVER TIME AND MAY CAUSE THE FURNITURE TO BE WOBBLY AND UNABLE TO SUPPORT ITS INTENDED WEIGHT CAPACITY. THIS MAY LEAD TO COLLAPSE AND MAY CAUSE SERIOUS INJURY.

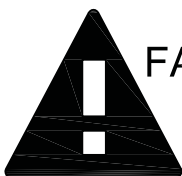

**FAILURE TO FOLLOW THE GUIDELINES ABOVE MAY RESULT IN INJURY AND/OR PROPERTY DAMAGE.**



Before you begin, please read Page 2 of "Assembly and Care Advice".

And remember, do not tighten until each step is completed or instructed.

### Parts List

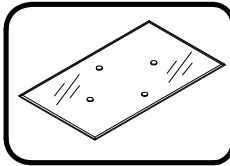
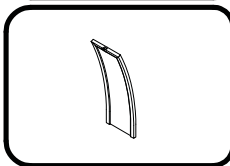
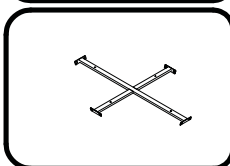
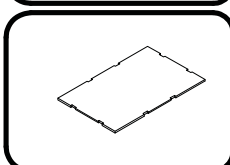
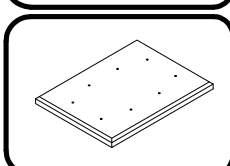
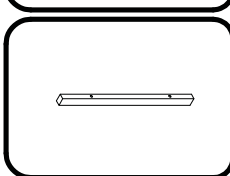
	#1 x 1pc Glass Top
	#2 x 4pcs Leg Stand
	#3 x 1pc Leg Support Frame
	#4 x 1pc Shelf
	#5 x 1pc Base
	#6 x 1pc Base Support Rail

### Hardware List

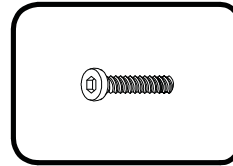
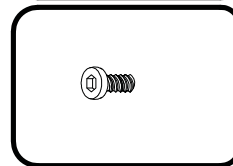
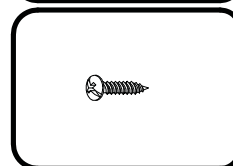
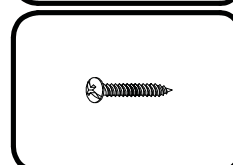
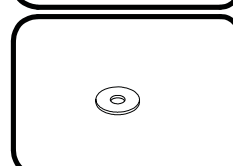
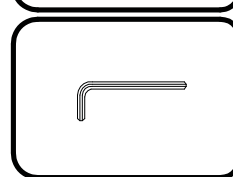
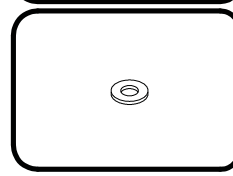
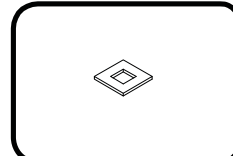
	#A x 8pcs Bolt 1/4" X1-3/8"
	#B x 12pcs Bolt 1/4" X 3/8"
	#C x 4pcs Screw M4 X 20mm
	#D x 2pcs Screw M4 X 40mm
	#E x 8pcs Flat Washer Ø20
	#F x 1pc Allen Wrench M4
	#G x 4pcs Flat Washer Ø12
	#H x 8pcs Plastic gasket



#B x 9pcs

2. Align the leg support frame (#3) to the holes along the center of the leg stands (#2). Insert 2 bolts (#B) into each end. Secure using the Allen wrench (#F).

1-1

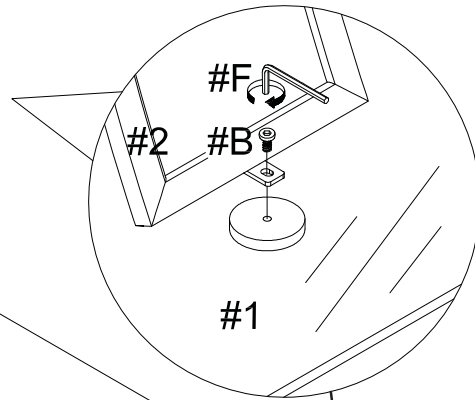

1-2

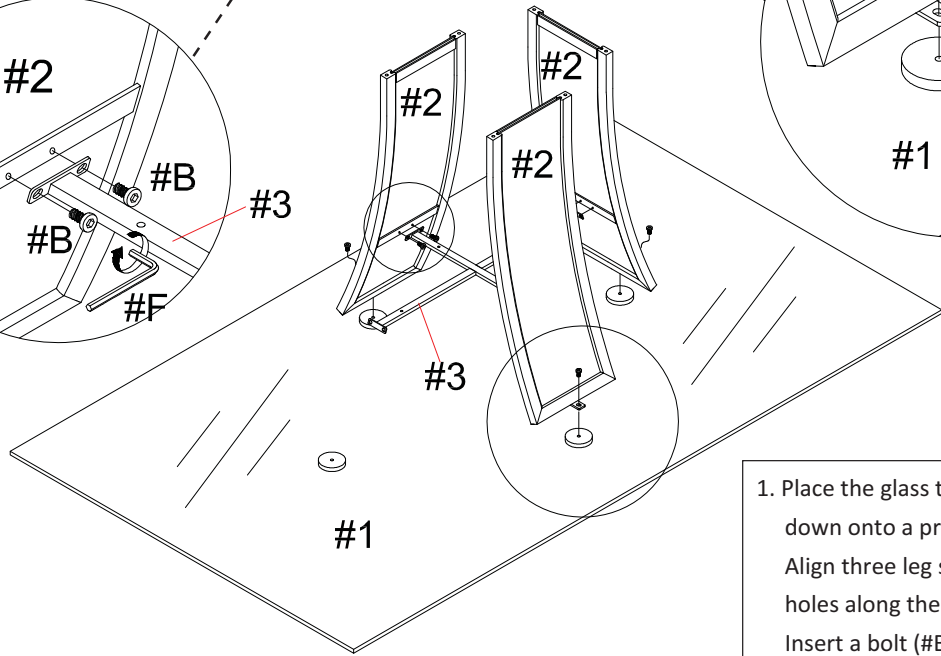
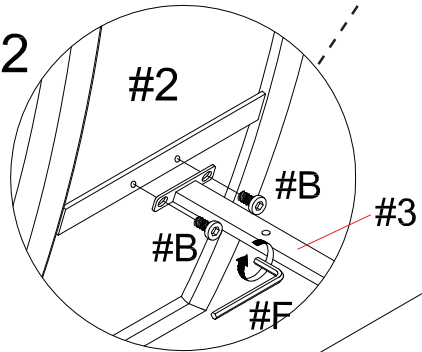

1. Place the glass top (#1) face down onto a protected surface. Align three leg stands (#2) to the holes along the glass top (#1). Insert a bolt (#B) into each hole. Secure using the Allen wrench (#F).



Slide the shelf (#4) face down under the leg support frame (#3).

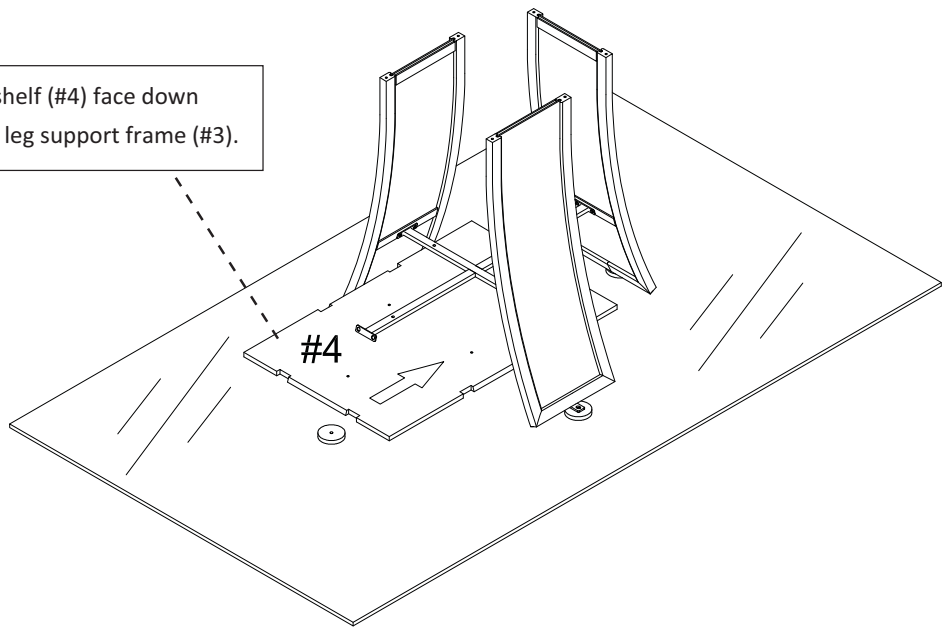



#B x 3pcs  
 #C x 4pcs  
 #G x 4pcs  
 #H x 8pcs

3-3

3-2

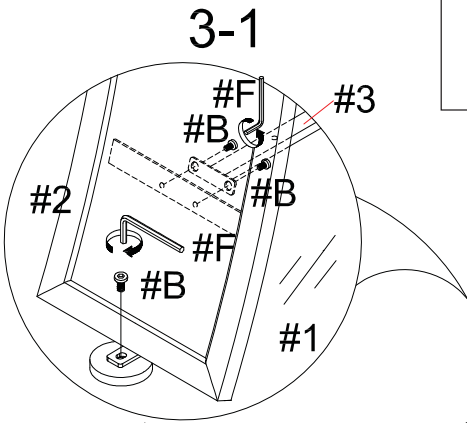

3. Place the plastic gaskets (#H) onto the bottom ends of the leg stands.

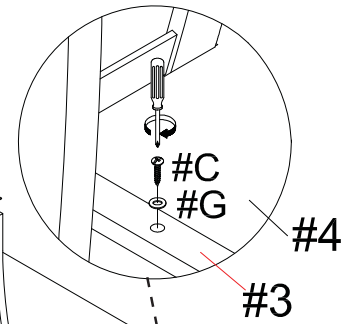
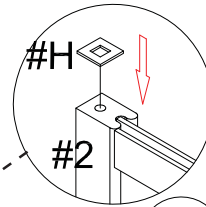

1. Align the fourth leg stand (#2) to the holes, then insert a bolt (#B) into the bottom hole and 2 bolts (#B) into the holes along the leg support frame (#3). Secure using the Allen wrench (#F).

2. Prepare 4 screws by inserting a flat washer (#G) onto the screws (#C), then lift and align the shelf (#4) to the leg support frame (#3). Insert a screw assembly into each and secure using a screwdriver.



1. Place the base (#5) face down onto the leg stands (#2). Prepare 8 bolt assemblies by inserting a flat washer (#E) onto the bolt (#A). Insert into the holes and secure using the Allen wrench (#F).

#A x 8pcs  
 #D x 2pcs  
 #E x 8pcs

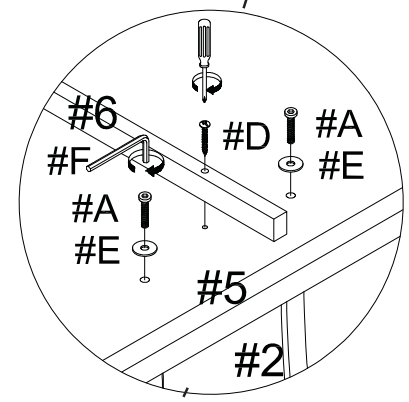
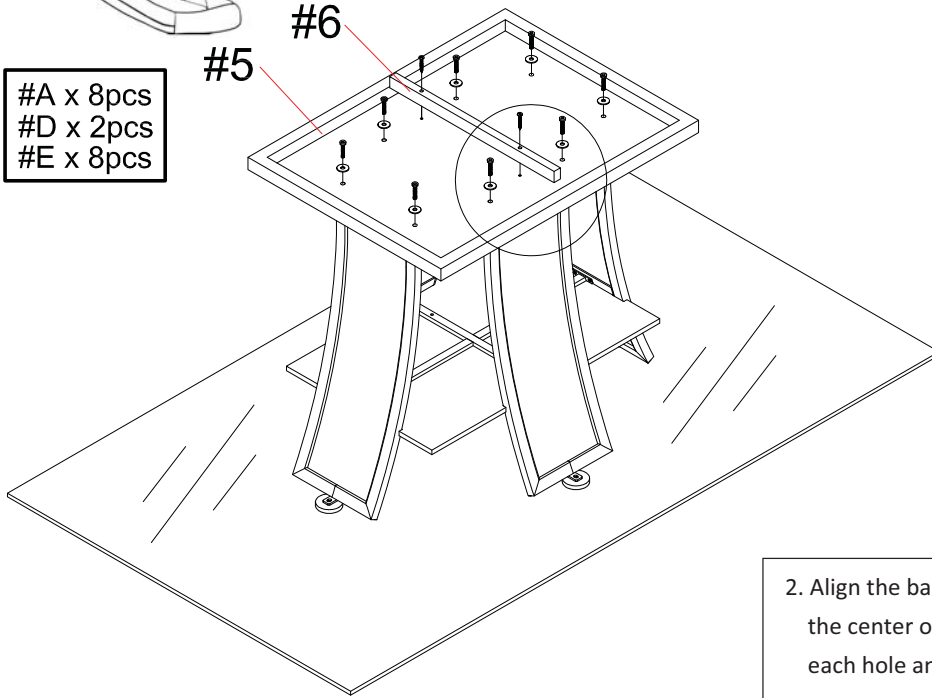

2. Align the base support rail (#6) to the holes along the center of the base (#5). Insert a screw (#D) into each hole and secure using a Phillips screwdriver.



Turn the table upright and make sure all parts are firmly secured.

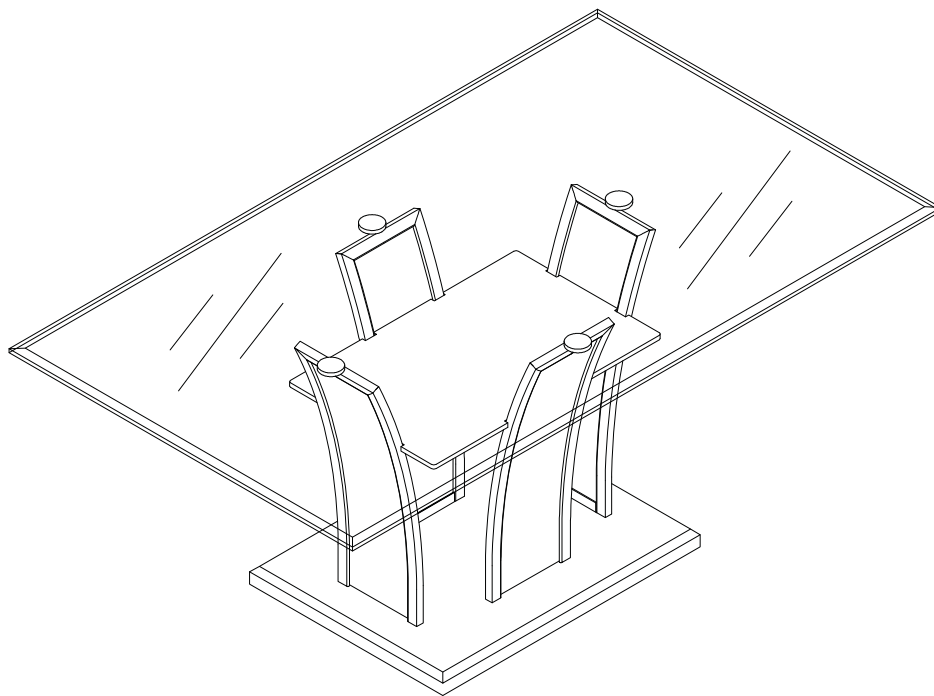

**ASSEMBLY IS COMPLETED**