

Furniture of America®

Assembly Instructions

For more information contact our team: service.ec@foagroup.com

CM7651T

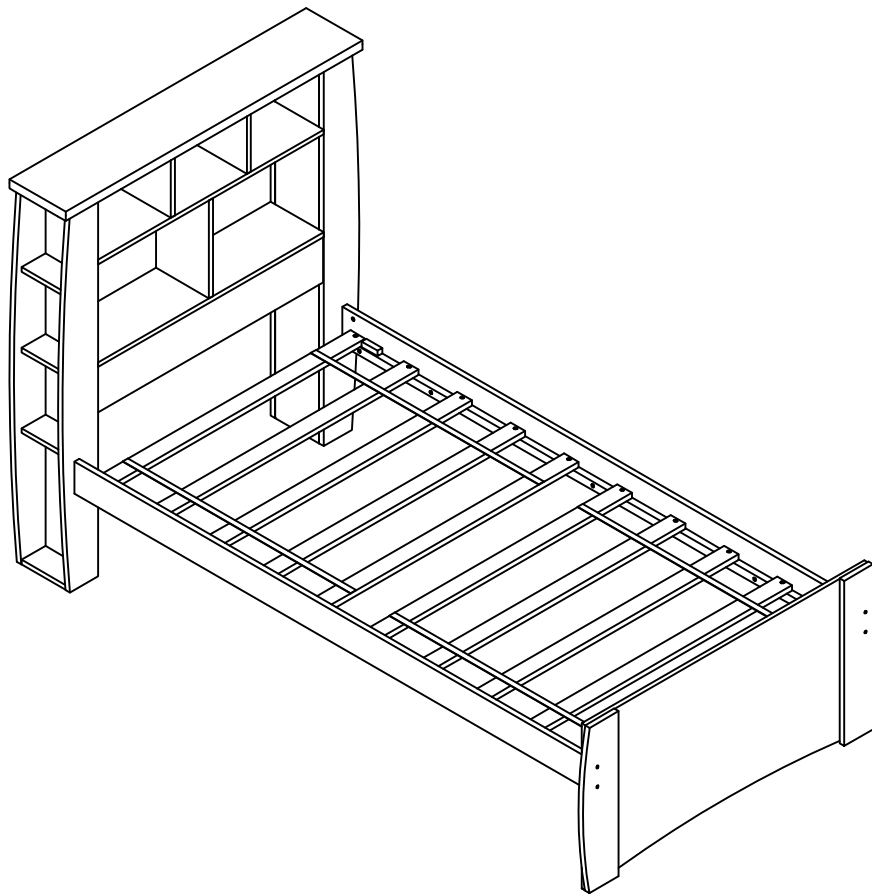

ASSEMBLY RATING

The Assembly Rating is a 5-point system that shows the degree of effort needed in assembling a specific product (with 1 being easy and 5 being difficult). For some products, two persons are recommended.

EASY  DIFFICULT

Tools Required For Assembly:

Allen Wrench

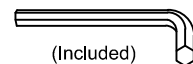

Phillips Screwdriver

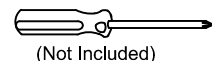

2 PERSONS RECOMMENDED

ASSEMBLY & CARE ADVICE

FOR YOUR FURNITURE TO LAST, CORRECT ASSEMBLY AND PROPER MAINTENANCE ARE NECESSARY. PLEASE FOLLOW THE INFORMATION PROVIDED BELOW TO FULLY ENJOY YOUR FURNITURE.

BASIC ASSEMBLY TECHNIQUES

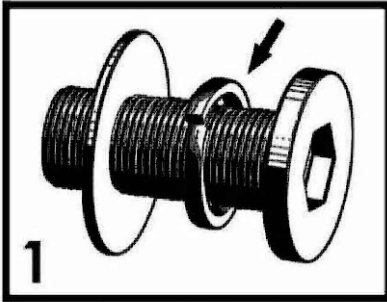

1
When lock or spring washer is used in an assembly, please make sure the lock or spring washer is placed between the larger flat washer and the head of the screw or bolt.

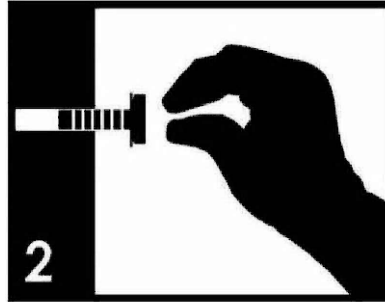

2
Position each part correctly and insert screws or bolts into their respective holes by hand tighten or using the proper hand tool. Only tighten when step is completed or when instructed to do so.

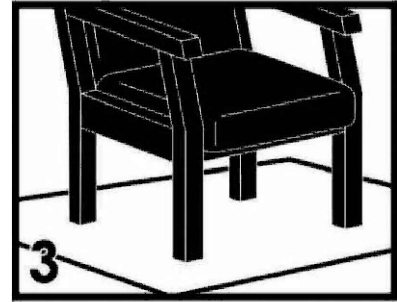

3
Use cardboard or carpet area when assembling furniture to prevent scratches. Make sure the furniture rests on a flat and level surface with each leg evenly touching the floor.

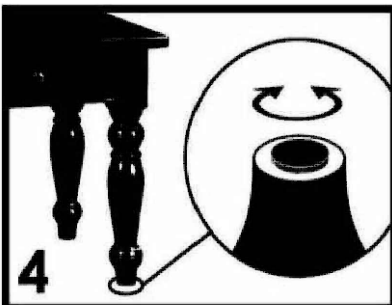

4
Some furniture comes with height adjustment knobs underneath each leg. To lower or to raise each leg, you need to turn clockwise or counterclockwise, respectively.

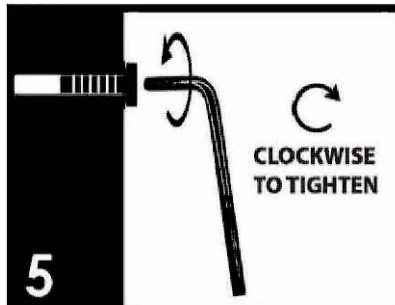

5
Make sure all parts are properly aligned, then use the appropriate hand tool to completely tighten the bolts or screws. Do not use power tools and do not overtighten.

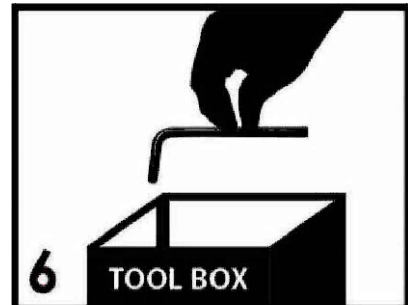

6
Save the instructions and store the Allen wrench or any supplied tool for later maintenance. After two weeks, check and tighten any loose hardware and repeat again every six months thereafter.

IT IS THE USER'S RESPONSIBILITY TO MAINTAIN THE FURNITURE. THE HARDWARE MAY LOOSEN OVER TIME AND MAY CAUSE THE FURNITURE TO BE WOBBLY AND UNABLE TO SUPPORT ITS INTENDED WEIGHT CAPACITY. THIS MAY LEAD TO COLLAPSE AND MAY CAUSE SERIOUS INJURY.



FAILURE TO FOLLOW THE GUIDELINES ABOVE MAY RESULT IN INJURY AND/OR PROPERTY DAMAGE.

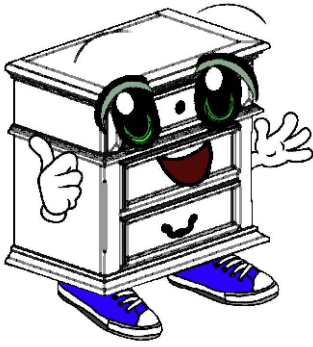

Before you begin, please read Page 2 of "Assembly and Care Advice".

And remember, do not tighten until each step is completed or instructed.

Parts List

Hardware List

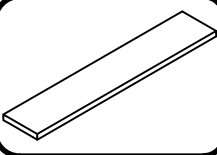
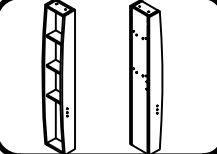
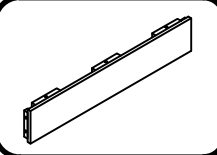
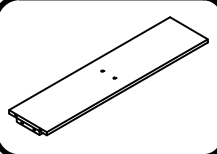
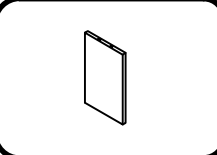
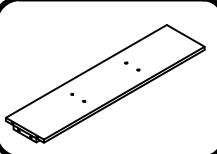
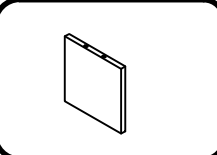
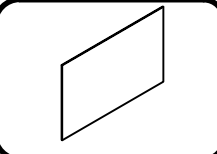
-  #1 x 1pc
Headboard Top Panel
-  #2 x 2pcs
Headboard Leg (L&R)
-  #3 x 1pc
Bottom shelf
-  #4 x 1pc
Middle shelf
-  #5 x 1pc
Bottom erect panel
-  #6 x 1pc
Upper shelf
-  #7 x 2pcs
Upper erect panel
-  #8 x 1pc
Back panel

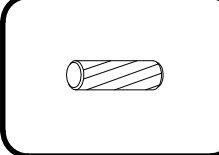
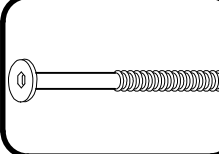
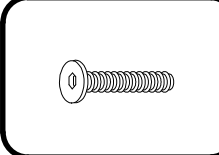
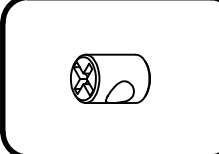
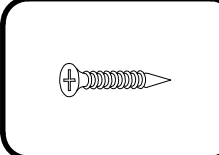
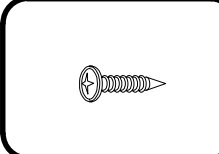
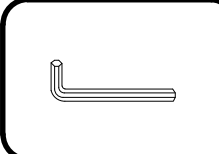
-  #A x 22pcs
Dowel Ø8 x 1-3/16"
-  #B x 8pcs
Bolt Ø1/4" x 2-3/4"
-  #C x 25pcs
Bolt Ø1/4" x 1-3/16"
-  #D x 8pcs
Barrel Nut Ø1/4"
-  #E x 20pcs
Wood Screw #8 x 30mm
-  #F x 24pcs
Wood Screw #8 x 15mm
-  #G x 1pc
Allen Wrench M4

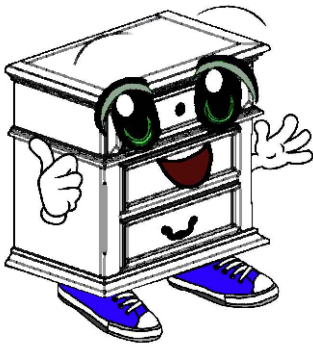

Before you begin, please read Page 2 of "Assembly and Care Advice".

And remember, do not tighten until each step is completed or instructed.

Parts List

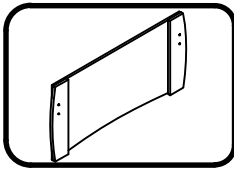

#9 x 1pc
Footboard panel

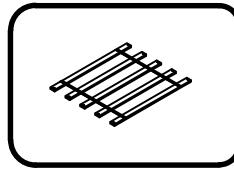

#11 x 2set
Slat (10pcs)

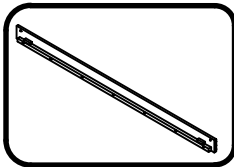

#10 x 2pcs
Side rails

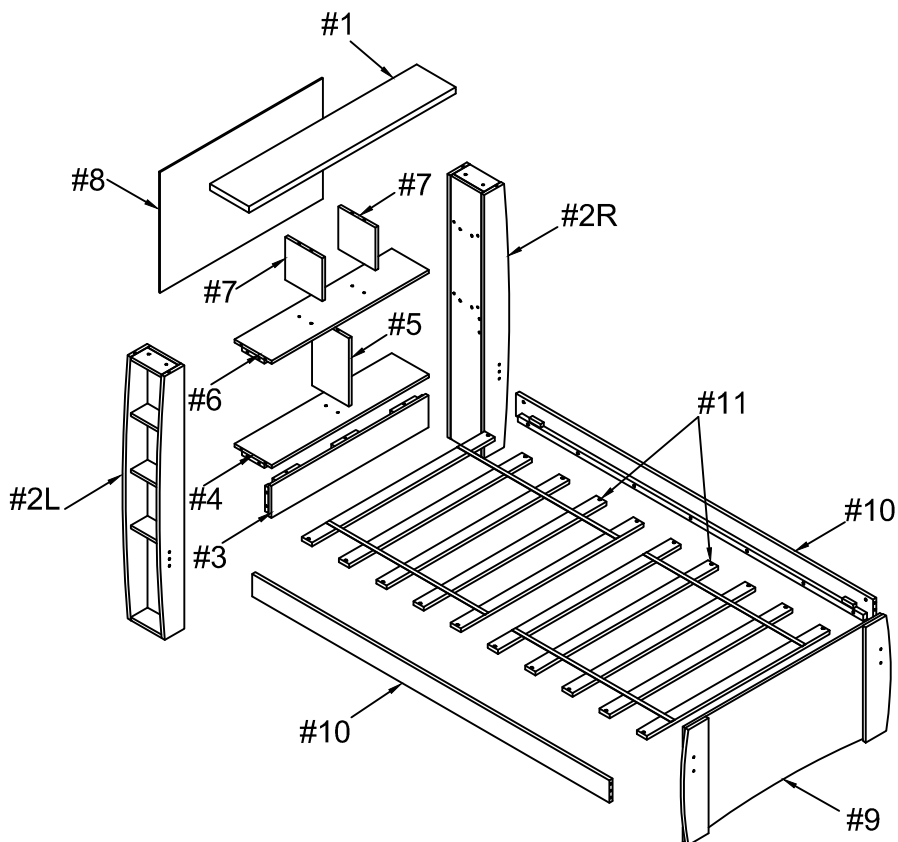



#C x 3pcs

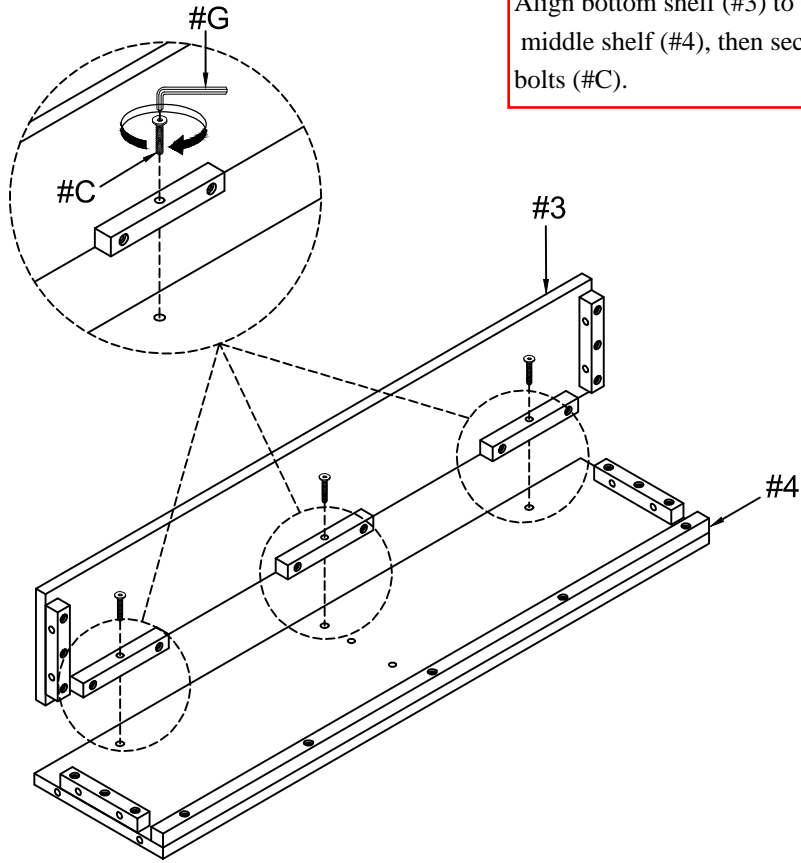

#C x 2pcs

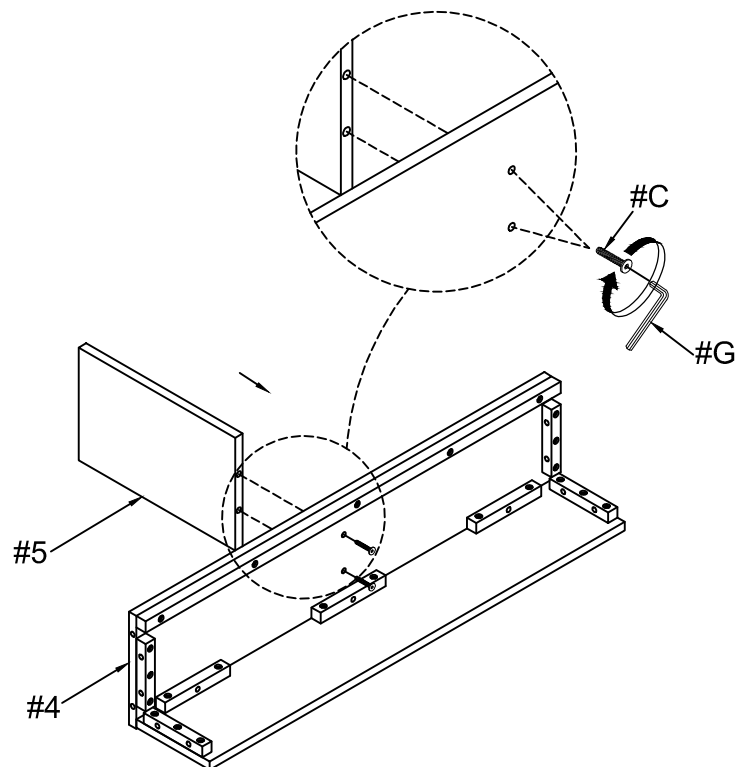



#A x 10pcs
#C x 12pcs

2) Attach dowels (#A) to the holes of the HB legs (#2R/L), then align shelves (#3,4,6) to the holes of the HB legs (#2R/L), then secure by using bolts (#C).

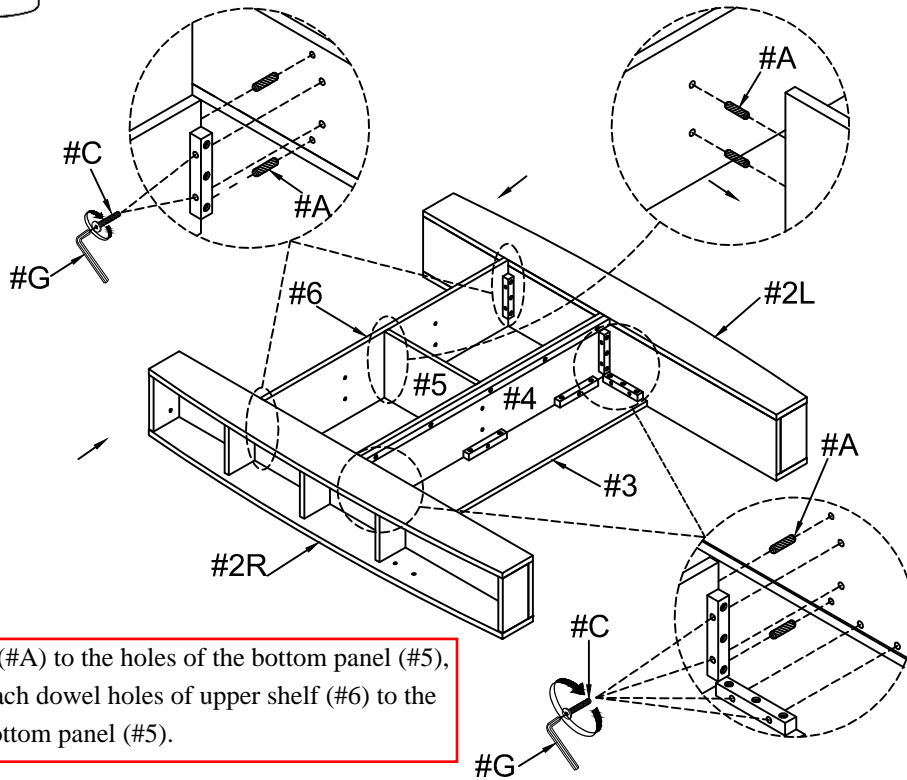

1) Attach dowels (#A) to the holes of the bottom panel (#5), then align and attach dowel holes of upper shelf (#6) to the dowels (#A) of bottom panel (#5).



#C x 4pcs

Align upper panel (#7) to the holes of the upper shelf (#6). Secure by using bolts (#C).

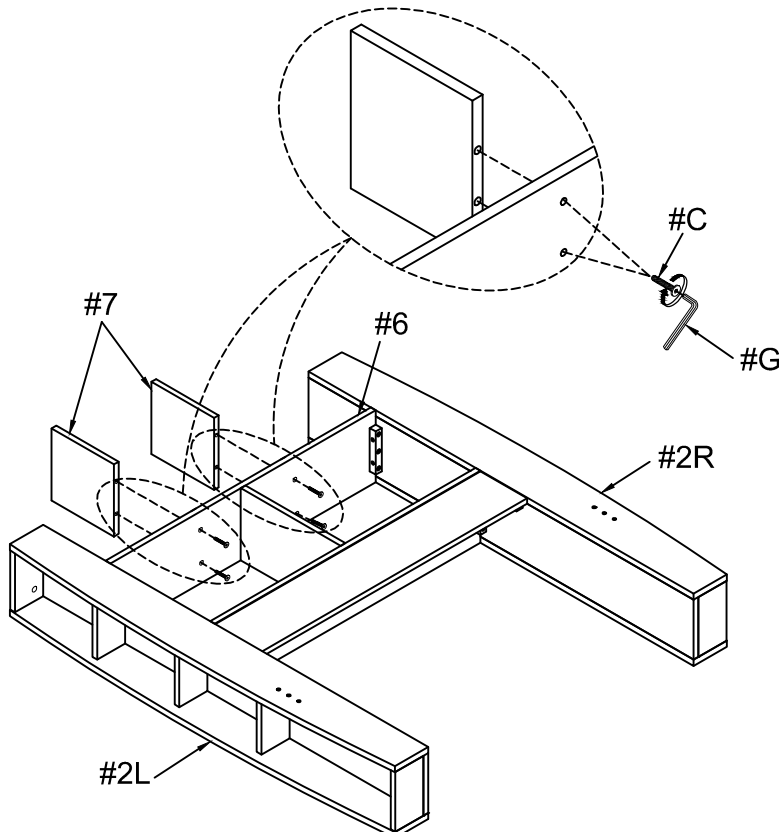



Attach dowels (#A) to the holes of headboard top panel (#1), then align top panel (#1) to the holes of the headboard base. Secure by using bolts (#C).

#A x 8pcs
#C x 4pcs

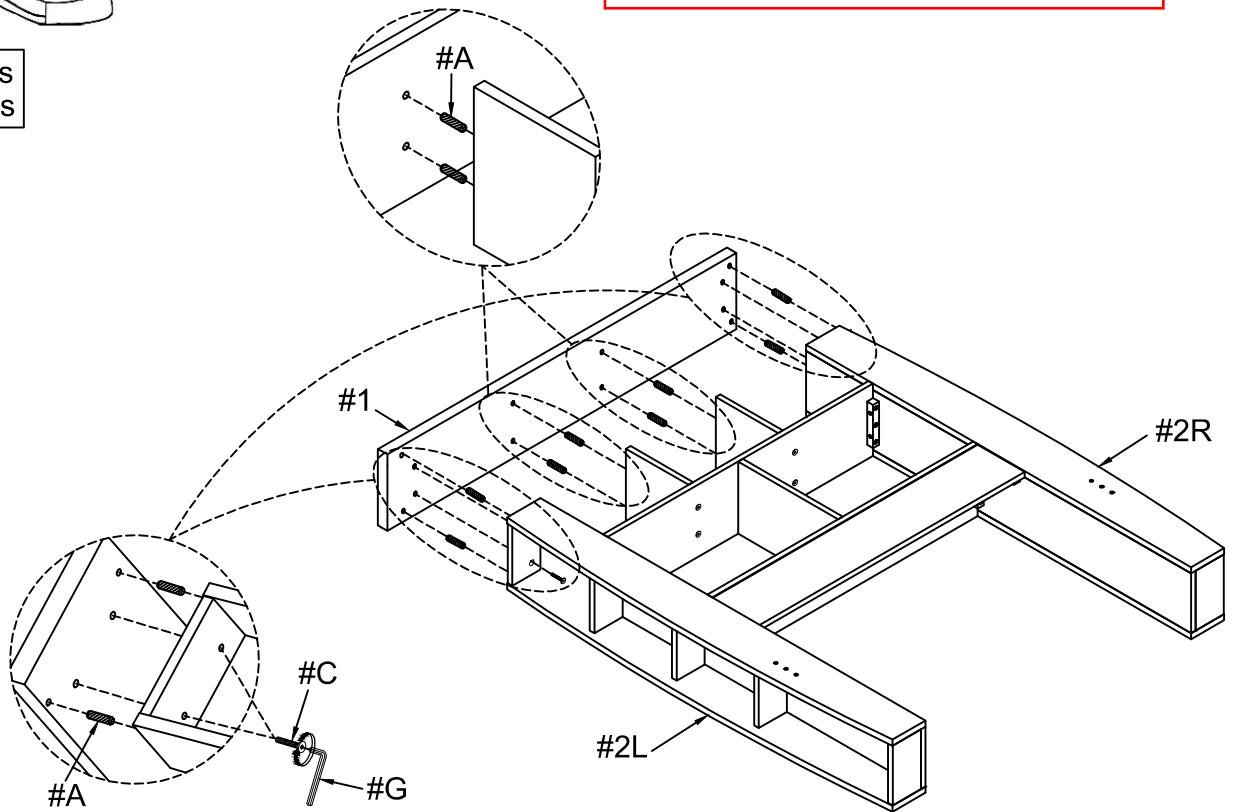

Align back panel (#8) to the back of the headboard. Secure by using screws (#F).

#F x 24pcs

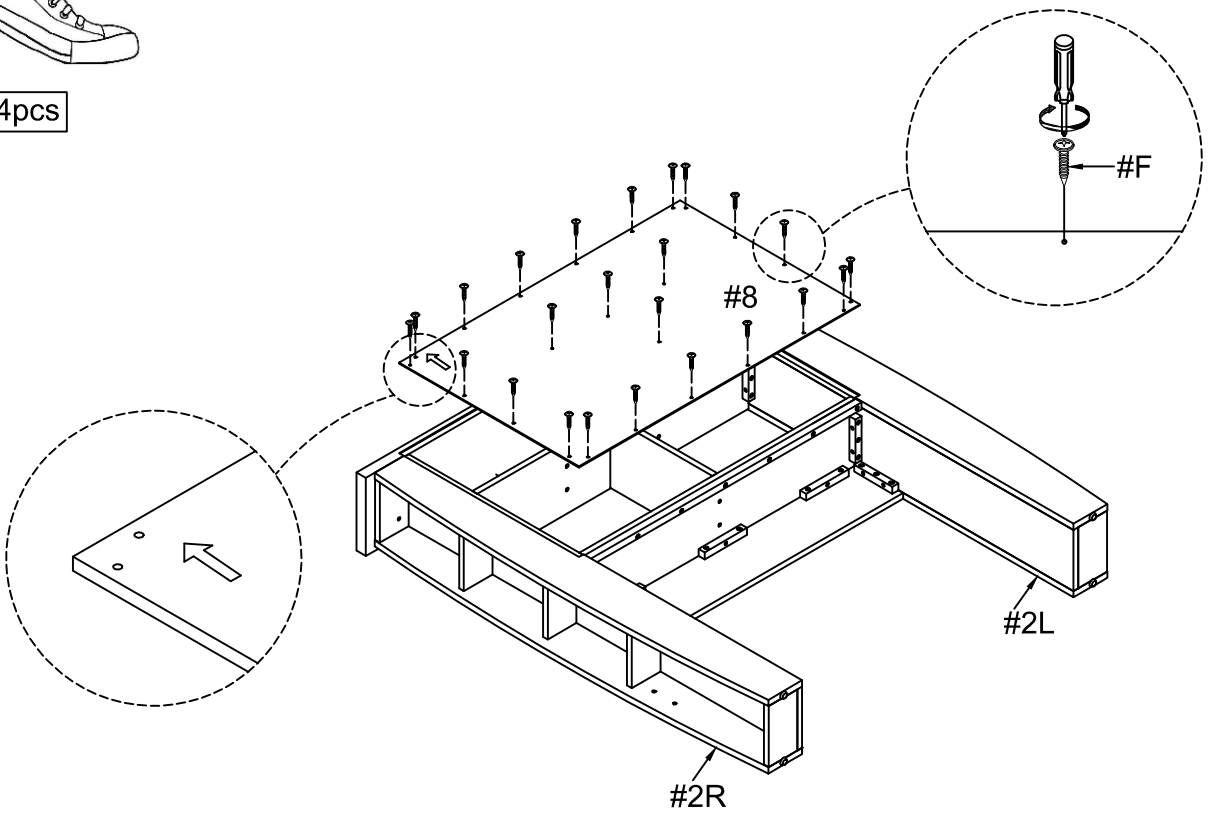



Attach dowel (#A) to the middle hole of the side rails (#10). Align side rails (#10) to the holes of the headboard legs (#2R/L) and footboard (#9). Insert barrel nuts (#D) to the holes of the side rails (#10), then secure by using bolts (#B) onto barrel nuts (#D).

#A x 4pcs
#B x 8pcs
#D x 8pcs

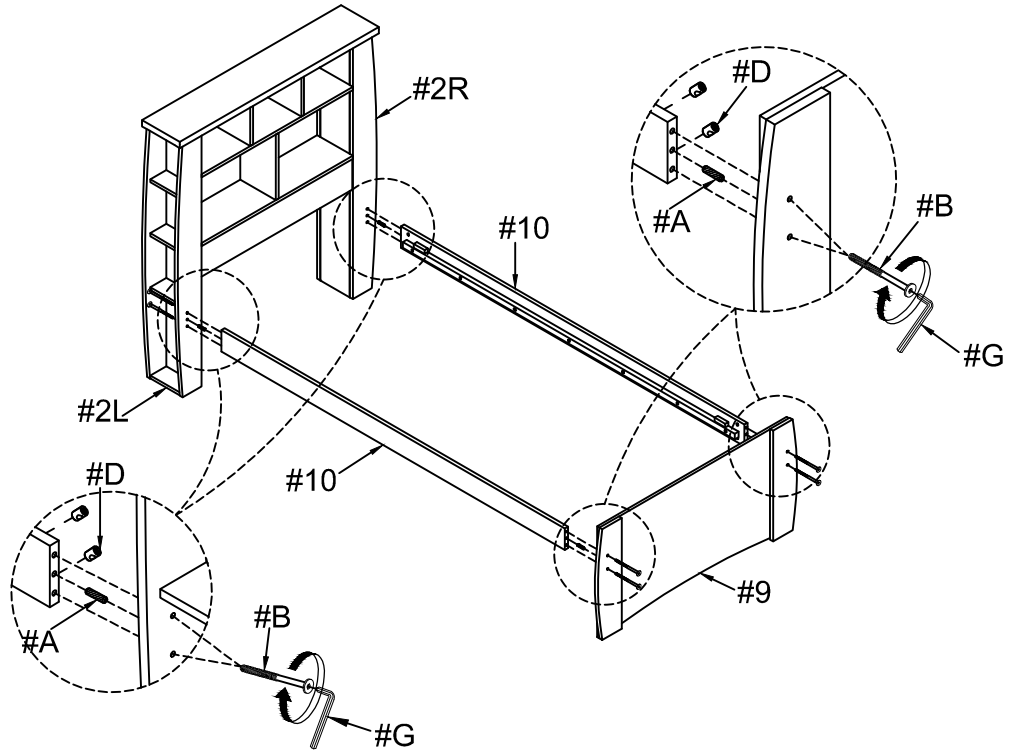

Align slat kit (#11) to the side rails (#10), then secure by using screws (#E).

#E x 20pcs

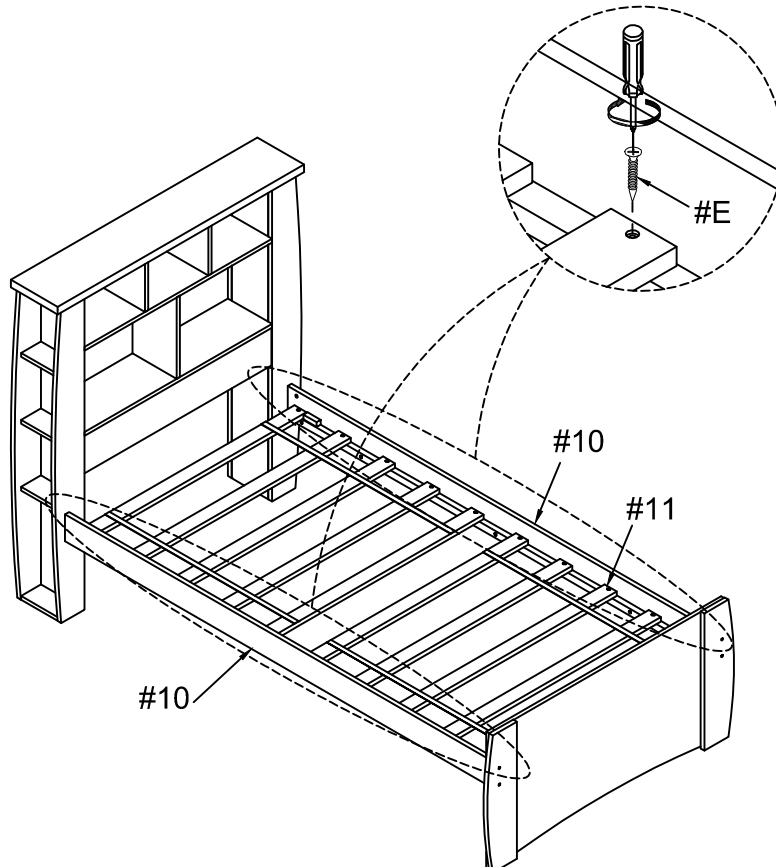

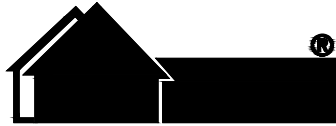

Furniture of America®

Assembly Instructions

For more information contact our team: service.ec@foagroup.com

CM7651F

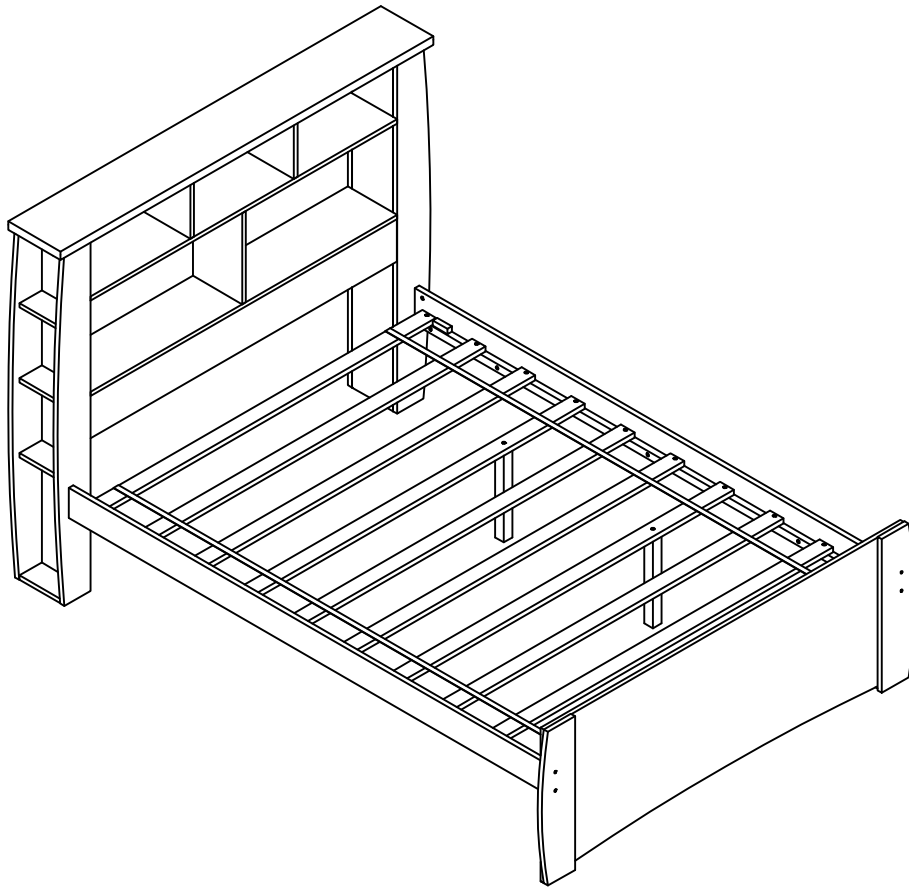

ASSEMBLY RATING

The Assembly Rating is a 5-point system that shows the degree of effort needed in assembling a specific product (with 1 being easy and 5 being difficult). For some products, two persons are recommended.

EASY  DIFFICULT

Tools Required For Assembly:

Allen Wrench

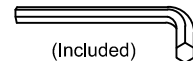

(Included)

Phillips Screwdriver



(Not Included)



2 PERSONS RECOMMENDED

ASSEMBLY & CARE ADVICE

FOR YOUR FURNITURE TO LAST, CORRECT ASSEMBLY AND PROPER MAINTENANCE ARE NECESSARY. PLEASE FOLLOW THE INFORMATION PROVIDED BELOW TO FULLY ENJOY YOUR FURNITURE.

BASIC ASSEMBLY TECHNIQUES

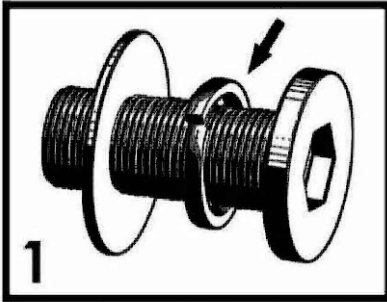

1
When lock or spring washer is used in an assembly, please make sure the lock or spring washer is placed between the larger flat washer and the head of the screw or bolt.

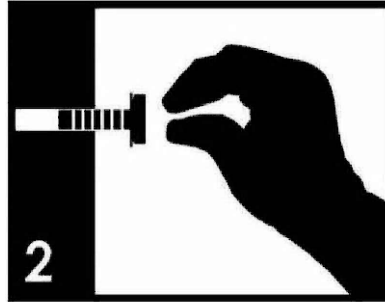

2
Position each part correctly and insert screws or bolts into their respective holes by hand tighten or using the proper hand tool. Only tighten when step is completed or when instructed to do so.

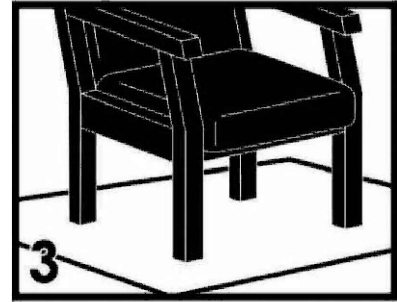

3
Use cardboard or carpet area when assembling furniture to prevent scratches. Make sure the furniture rests on a flat and level surface with each leg evenly touching the floor.

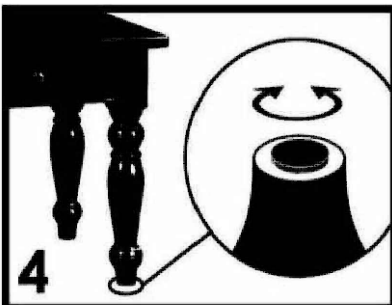

4
Some furniture comes with height adjustment knobs underneath each leg. To lower or to raise each leg, you need to turn clockwise or counterclockwise, respectively.

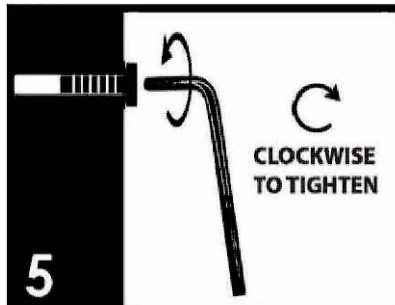

5
Make sure all parts are properly aligned, then use the appropriate hand tool to completely tighten the bolts or screws. Do not use power tools and do not overtighten.

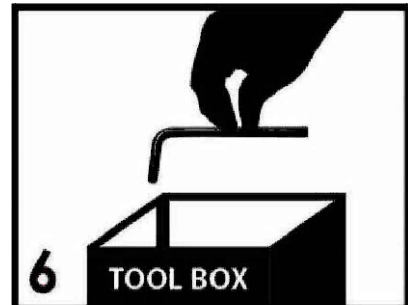

6
Save the instructions and store the Allen wrench or any supplied tool for later maintenance. After two weeks, check and tighten any loose hardware and repeat again every six months thereafter.

IT IS THE USER'S RESPONSIBILITY TO MAINTAIN THE FURNITURE. THE HARDWARE MAY LOOSEN OVER TIME AND MAY CAUSE THE FURNITURE TO BE WOBBLY AND UNABLE TO SUPPORT ITS INTENDED WEIGHT CAPACITY. THIS MAY LEAD TO COLLAPSE AND MAY CAUSE SERIOUS INJURY.



FAILURE TO FOLLOW THE GUIDELINES ABOVE MAY RESULT IN INJURY AND/OR PROPERTY DAMAGE.

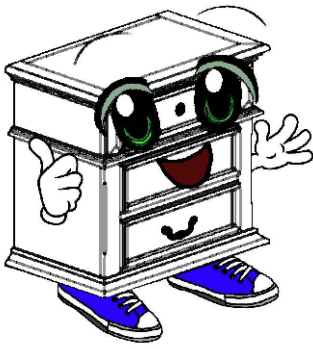



Before you begin, please read Page 2 of "Assembly and Care Advice".

And remember, do not tighten until each step is completed or instructed.

Parts List

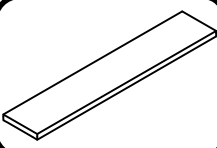
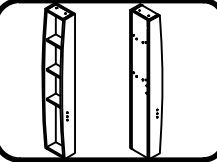
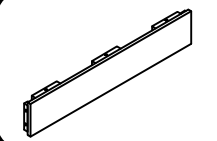
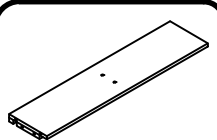
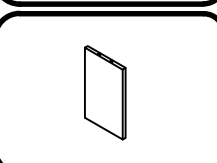
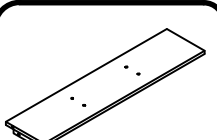
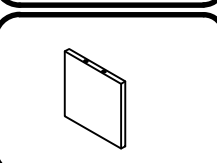
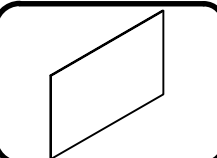
Hardware List

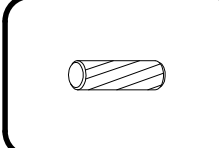
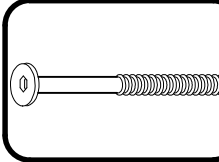
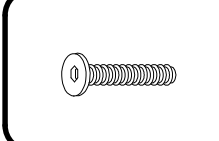
-  #1 x 1pc
Headboard Top Panel
-  #2 x 2pcs
Headboard Leg(L&R)
-  #3 x 1pc
Bottom shelf
-  #4 x 1pc
Middle shelf
-  #5 x 1pc
Bottom erect panel
-  #6 x 1pc
Upper shelf
-  #7 x 2pcs
Upper erect panel
-  #8 x 1pc
Back panel

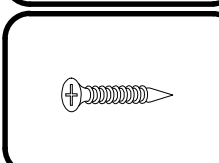
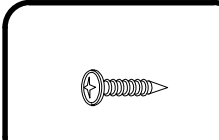
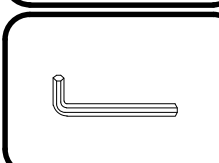
-  #A x 22pcs
Dowel $\text{Ø}5/16"$ x 1-3/16"
-  #B x 8pcs
Bolt $\text{Ø}1/4"$ x 2-3/4"
-  #C x 25pcs
Bolt $\text{Ø}1/4"$ x 1-3/16"
-  #D x 8pcs
Barrel Nut $\text{Ø}1/4"$
-  #E x 20pcs
Wood Screw #8 x 30mm
-  #F x 30pcs
Wood Screw #8 x 15mm
-  #G x 1pc
Allen Wrench M4

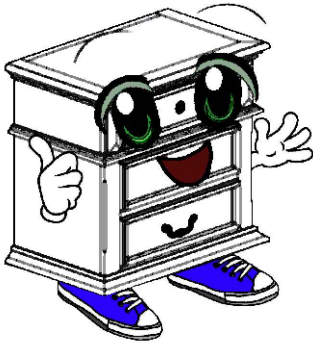

Before you begin, please read Page 2 of "Assembly and Care Advice".

And remember, do not tighten until each step is completed or instructed.

Parts List

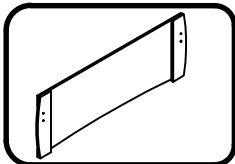

#9 x 1pc
Footboard panel

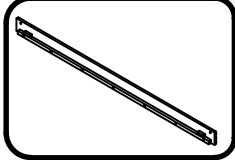

#10 x 2pcs
Side rails

Hardware List

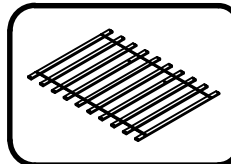

#11 x 1set
Slat (10pcs)

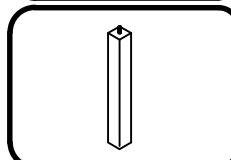

#12 x 2pcs $\text{\O}1/4"$
Support Leg 315x35x35

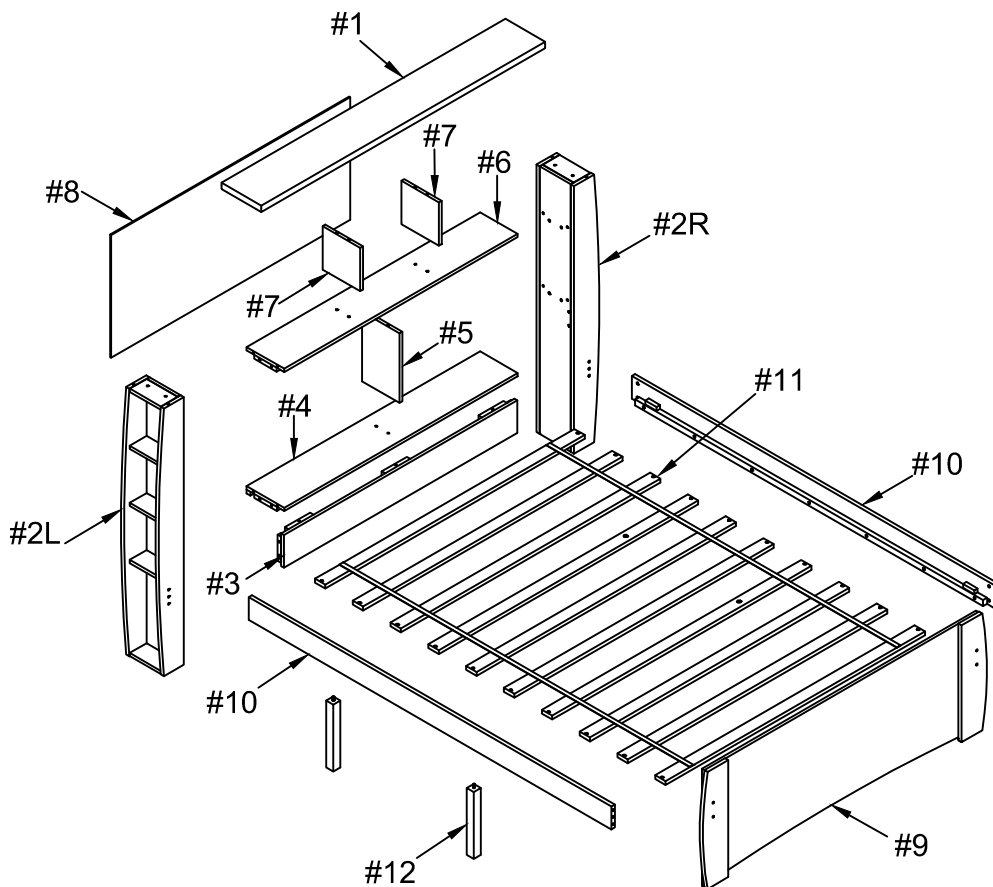



#1

#C x 3pcs

Align bottom shelf (#3) to the holes of the middle shelf (#4), then secure by using bolts (#C).

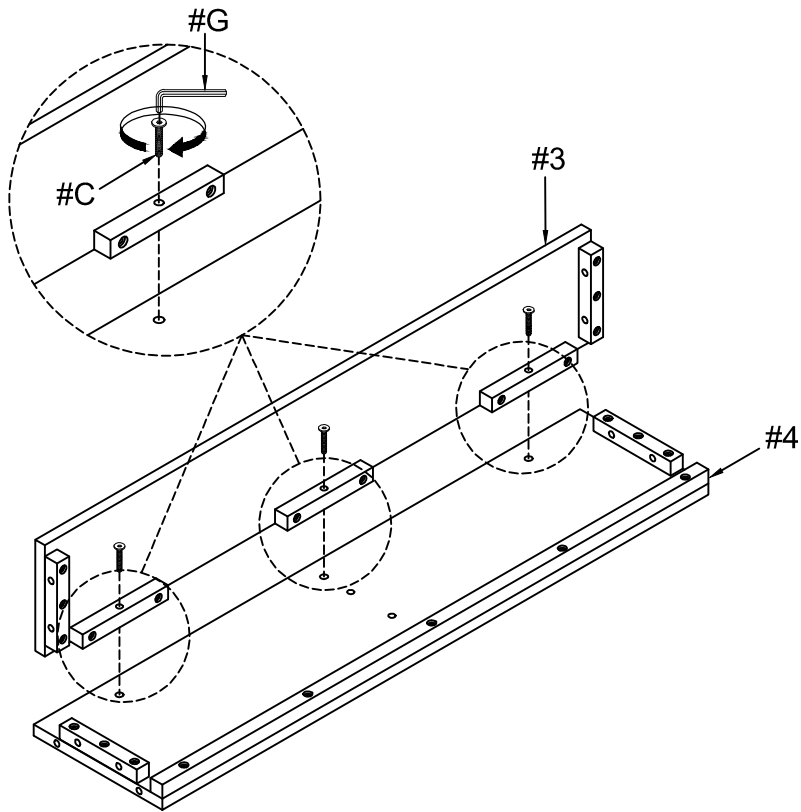

#2

#C x 2pcs

Align bottom shelf (#5) to the holes of the middle shelf (#4), then secure by using bolts (#C).

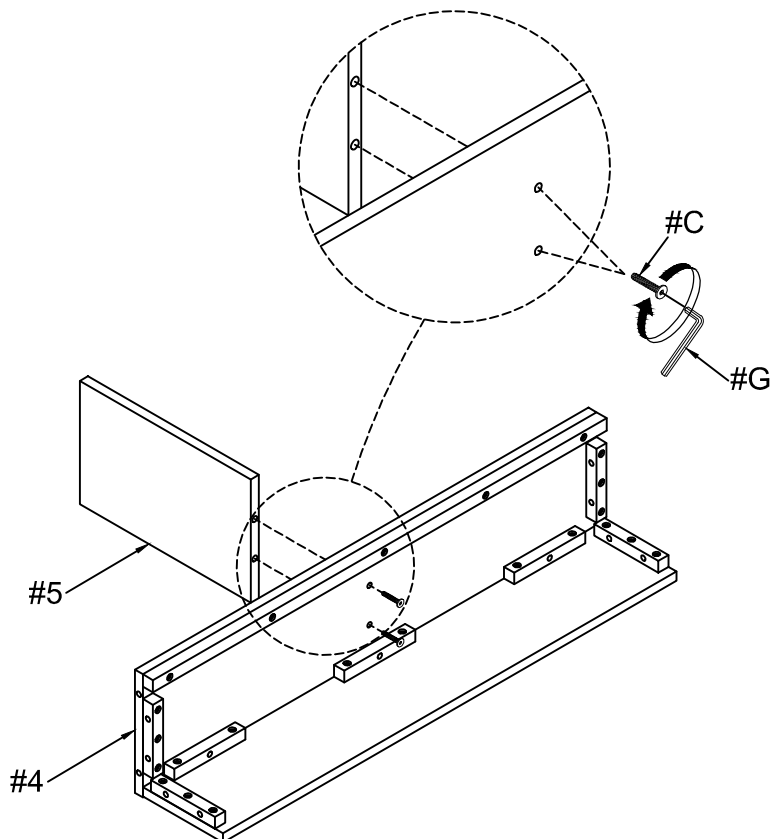



#A x 10pcs
#C x 12pcs

2) Attach dowels (#A) to the holes of the HB legs (#2R/L), then align shelves (#3,4,6) to the holes of the HB legs (#2R/L), then secure by using bolts (#C).

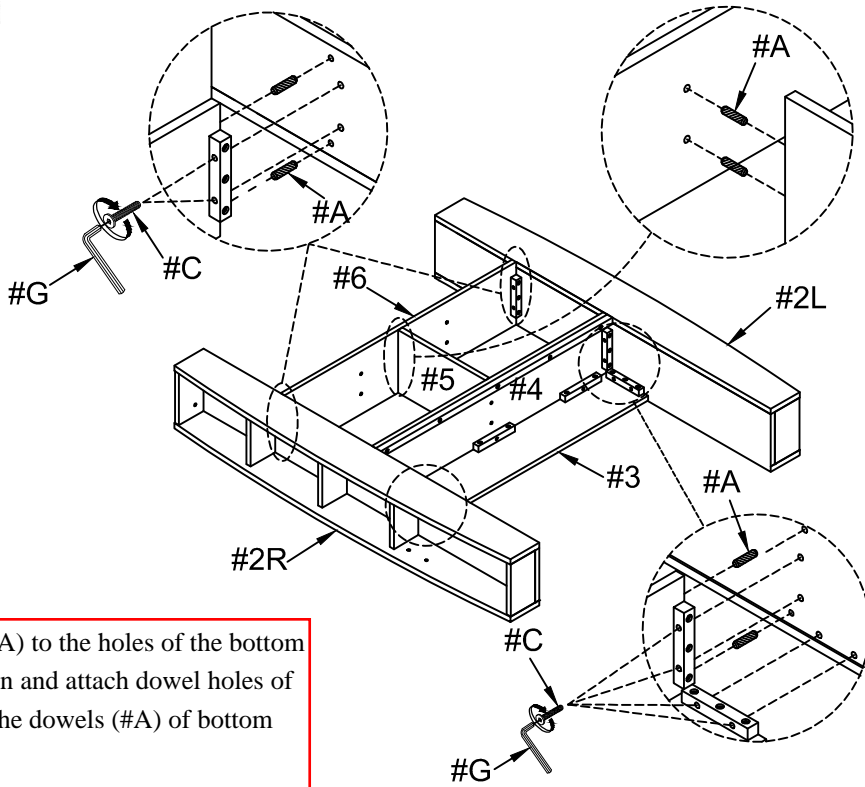

1) Attach dowels (#A) to the holes of the bottom panel (#5), then align and attach dowel holes of upper shelf (#6) to the dowels (#A) of bottom panel (#5).



#C x 4pcs

Align upper panel (#7) to the holes of the upper shelf (#6). Secure by using bolts (#C).

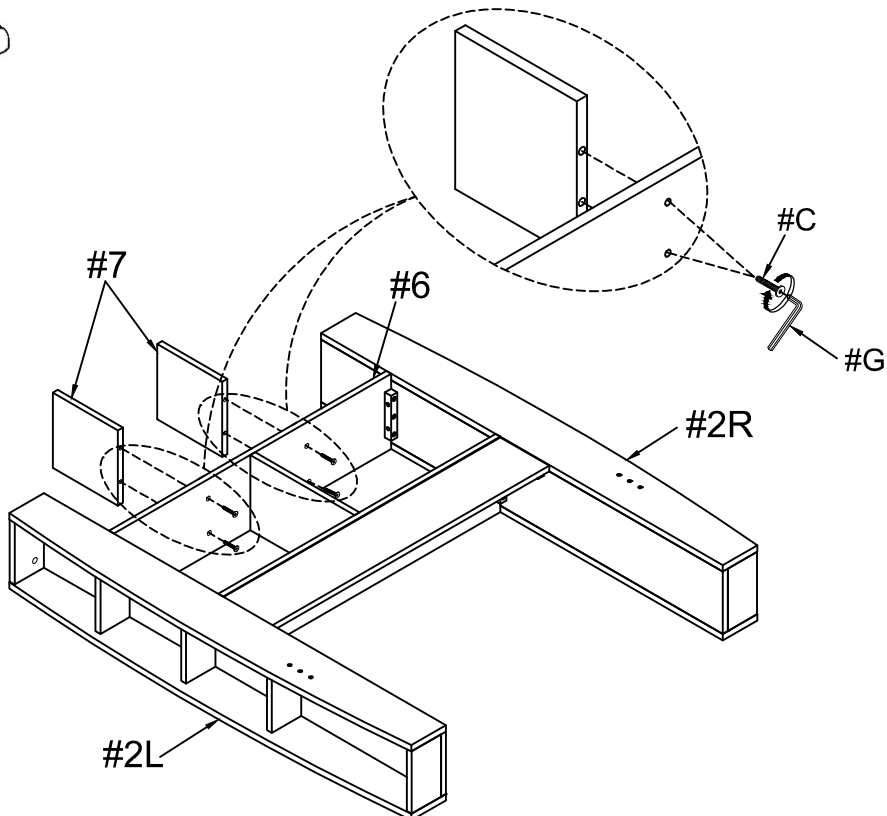



Attach dowels (#A) to the holes of headboard top panel (#1), then align top panel (#1) to the holes of the headboard base. Secure by using bolts (#C).

#A x 8pcs
#C x 4pcs

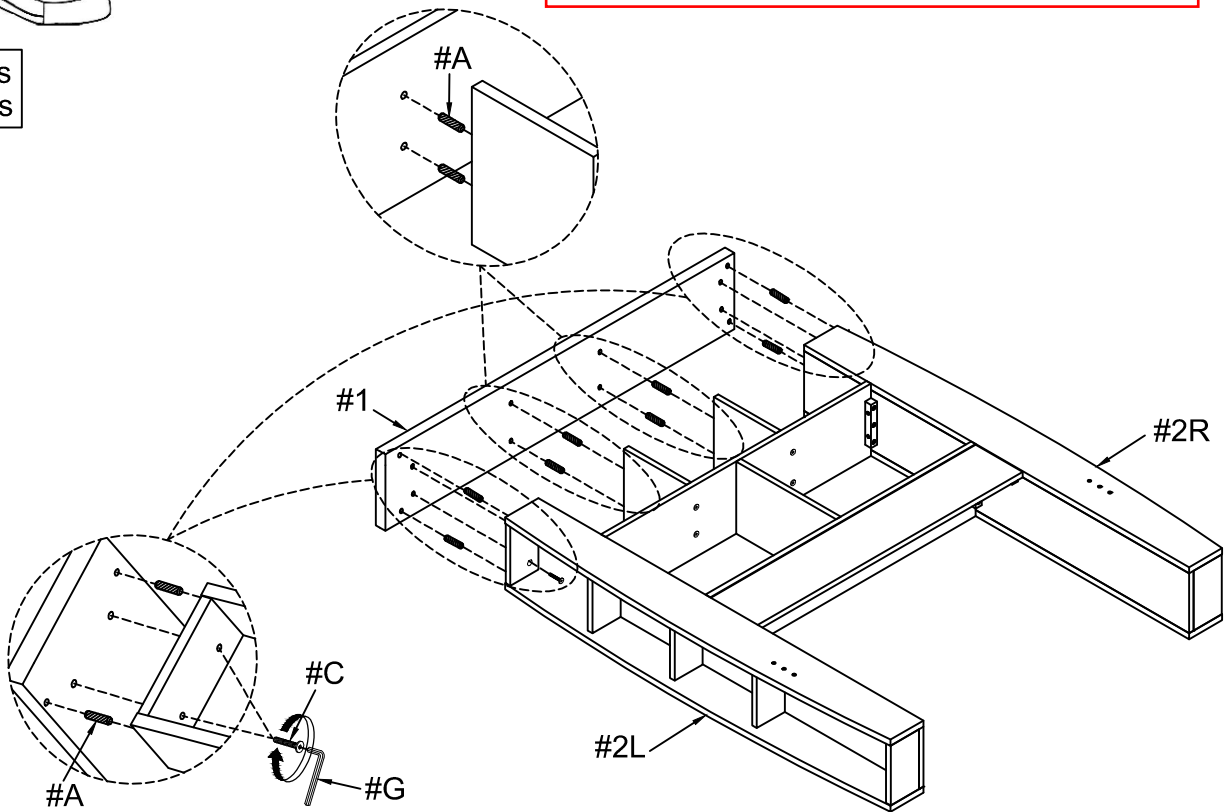

Align back panel (#8) to the back of the headboard. Secure by using screws (#F).

#F x 30pcs

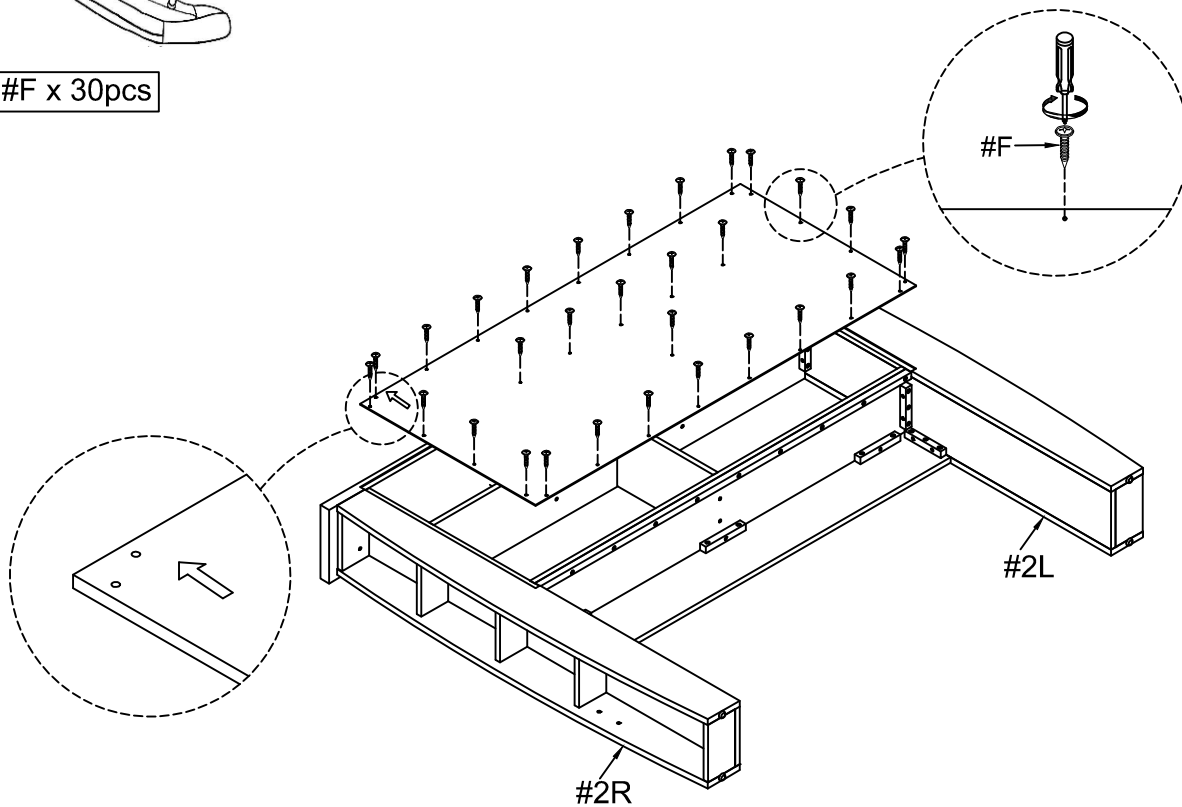



Attach dowel (#A) to the middle hole of the side rails (#10). Align side rails (#10) to the holes of the headboard legs (#2R/L) and footboard (#9). Insert barrel nuts (#D) to the holes of the side rails (#10), then secure by using bolts (#B) onto barrel nuts (#D).

#A x 4pcs
#B x 8pcs
#D x 8pcs

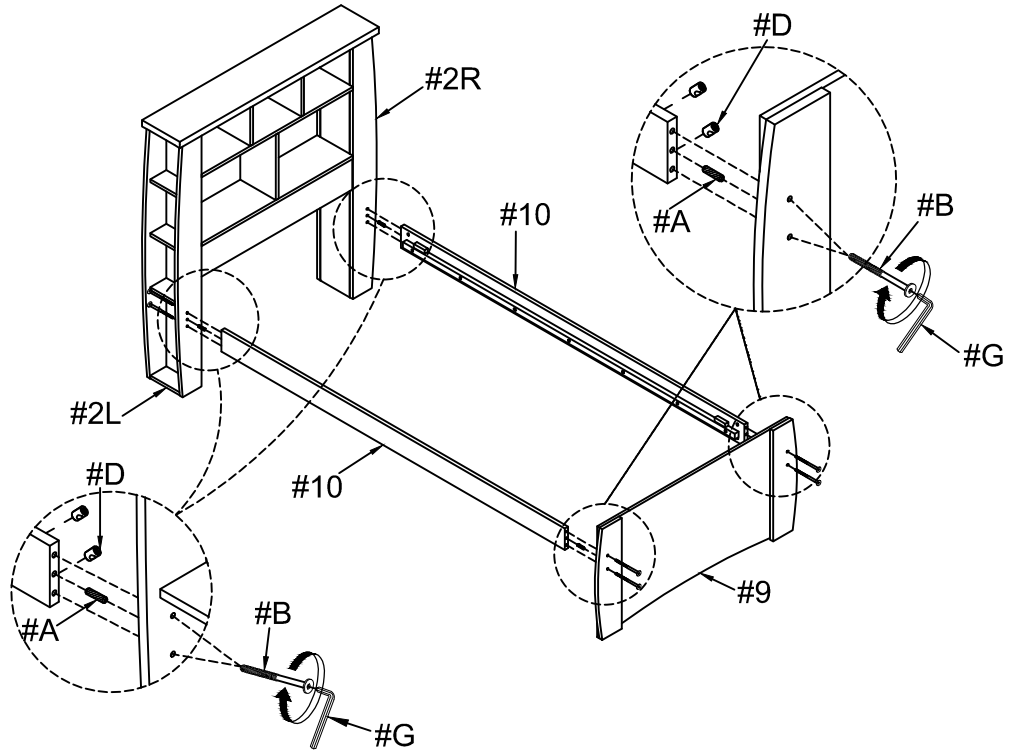

Attach support legs (#12) to the holes of the slat kit (#11). Adjust leveler on the support leg (#12) according to ground level.

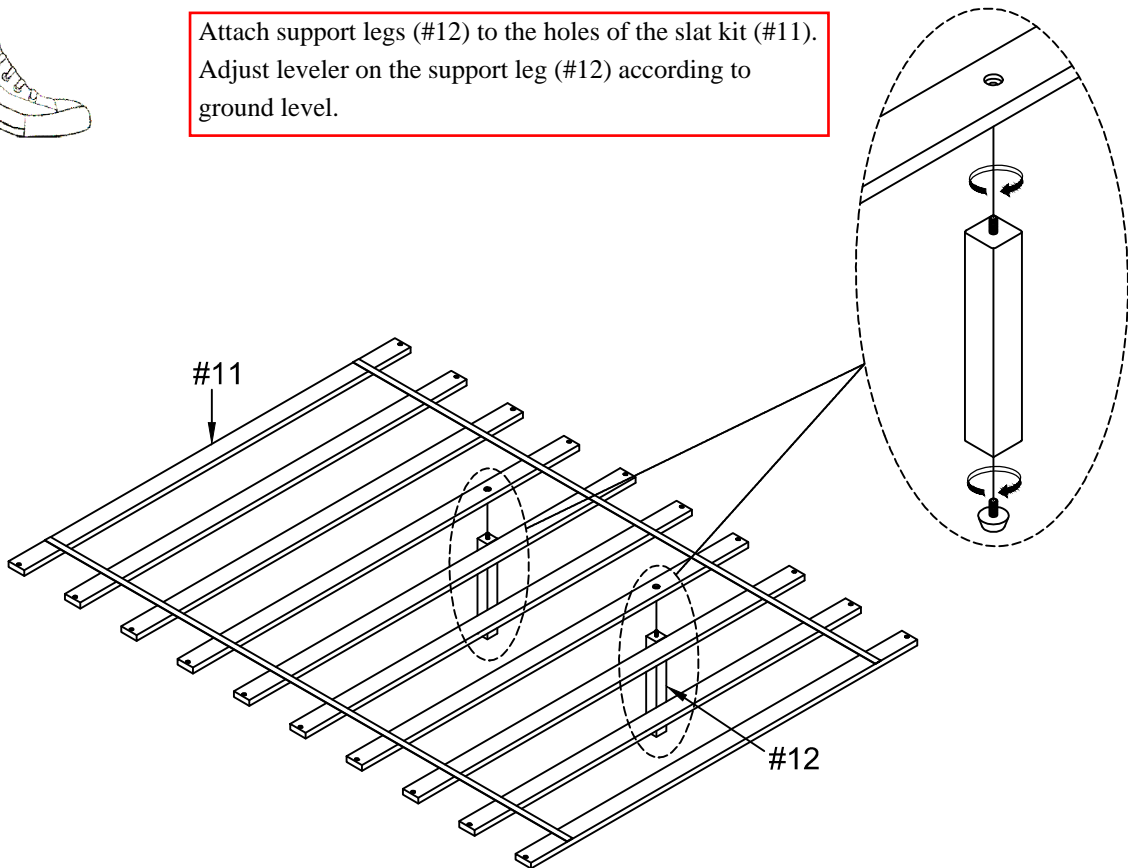



Align slat kit (#11) to the side rails (#10), then secure by using screws (#E).

#E x 20pcs

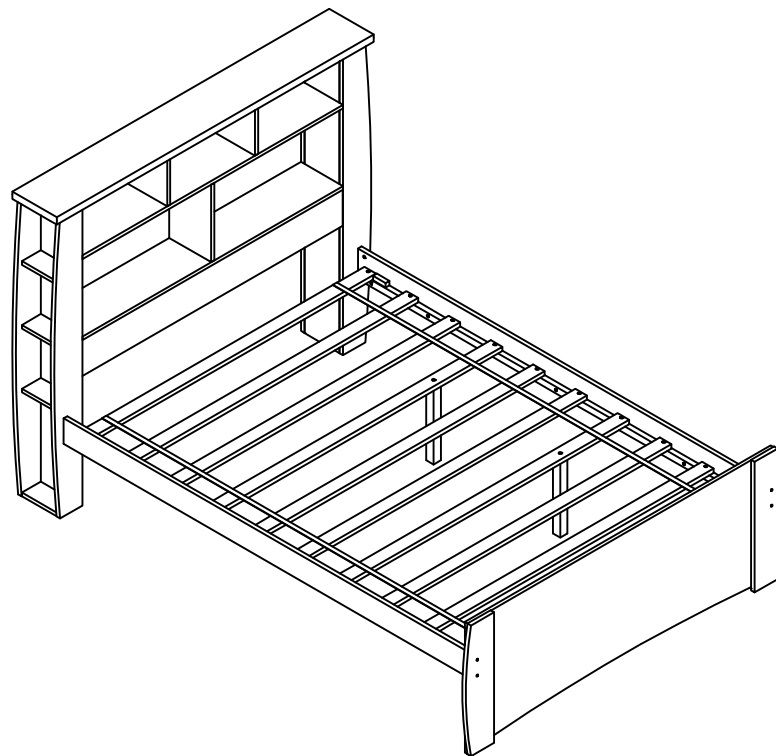
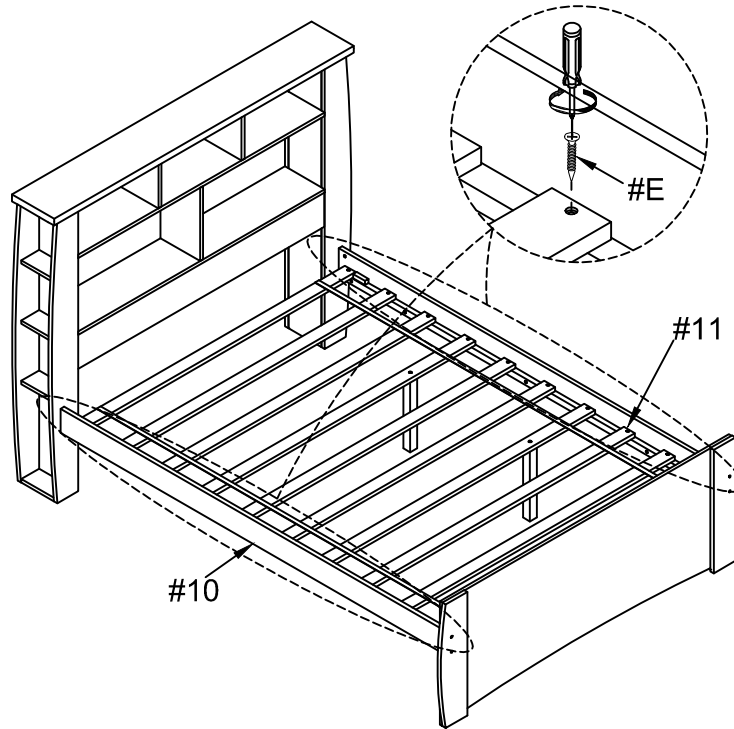

ASSEMBLY IS COMPLETED