

ASSEMBLY INSTRUCTIONS

MODEL #

CM7302EK

Questions?

GIVE US CALL: 1-888-980-5122
MON-FRI 8:30AM - 5:30PM (PST)

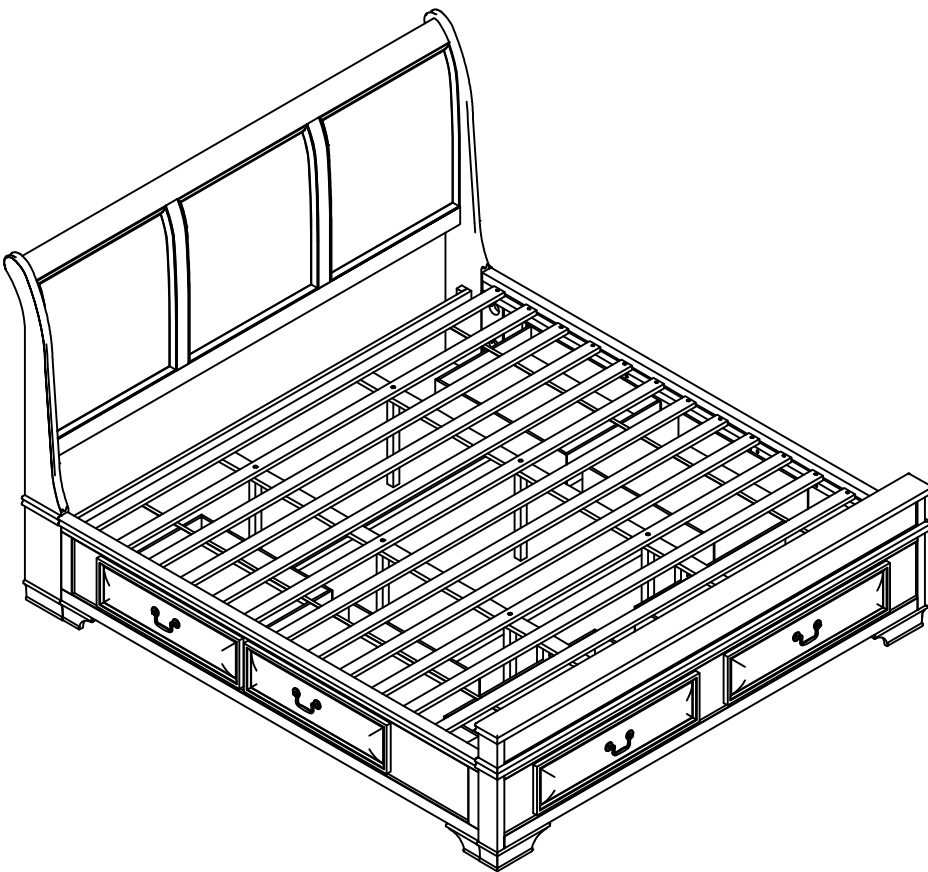

TOOLS REQUIRED



Allen Wrench

(Included)



Phillips
Screwdriver

(Not Included)



3 - People
Recommended

ASSEMBLY RATING



EASY —————> DIFFICULT

The Assembly Rating is a 5-point system showing the level of effort needed to assemble a specific product.



FOA Intro

Thank you for your purchase!

We hope you enjoy this new addition to your home for many years to come.

Our commitment to providing quality products does not simply end when you purchase our product. We fully stand behind our products from start to finish. Our customer service department is available Monday – Friday 8:30 AM – 5:30 PM Pacific and can help with assembly questions as well as, if necessary, replacing damaged or missing parts. To help expedite our service, please have these assembly instructions readily available, along with your order receipt.

 **Consumer Hotline**
Toll-Free 1-888-980-5122

 **WEBSITE**
www.foagroup.com

    foagroup

 **Monday to Friday**
8:30AM- 5:30PM (PST)

 **E-MAIL**
cs.ec@foagroup.com

 FurnitureOfAmerica

CHECK BEFORE STARTING

Are you missing anything?

Double-check all parts, hardware and accessories listed on Page 6 are accounted for.

Should we send any replacements?

Are there any irregularities or flaws in the parts? We can send replacements!

Check out our Quick Tips!

We recommend reviewing the pre-assembly handouts. Even experts need a refresher now and then!

Prep Time!

Please review the assembly instructions and all diagrams prior to assembling. Arrange parts as recommended on Page 7 and group identical hardware together to make assembling easier.

PRE ASSEMBLY INTRODUCTION

We understand building ready-to-assemble furniture can be a challenging experience for some. To help avoid confusion, we have provided some helpful tips that may speed up the process.



Teamwork

ALWAYS have at least two people to help with transporting and assembling the product to avoid potential injury and/or damage.



Suitable Location

Assembling near the area of the intended location is highly recommended.



Sufficient Space

Make sure you have enough space to move around during the assembly.



Avoid Scratches

Use cardboard, blankets or a carpeted area while assembling furniture to prevent scratches.

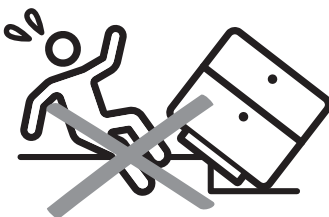

Flat Surface

Make sure the furniture rests on a flat and level surface with each leg evenly touching the floor.

ASSEMBLY AND CARE ADVICE



FAILURE TO FOLLOW THE GUIDELINES BELOW MAY RESULT IN INJURY AND/OR PROPERTY DAMAGE.



Position each part correctly and insert screws or bolts into their respective holes.

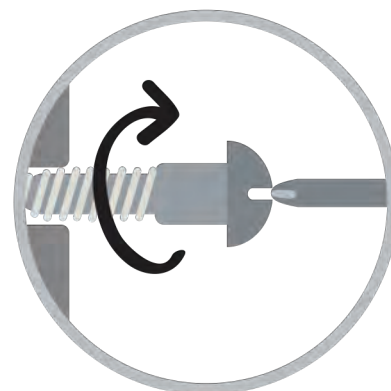

Turn clockwise to tighten and only tighten when step is completed or when instructed to do so.



Use the appropriate hand tools or power tools for assembly. Select steps, such as tightening screws and/or bolts, may require hand tools to avoid causing damage during assembly.



Save the instructions and store any supplied tools for later maintenance.

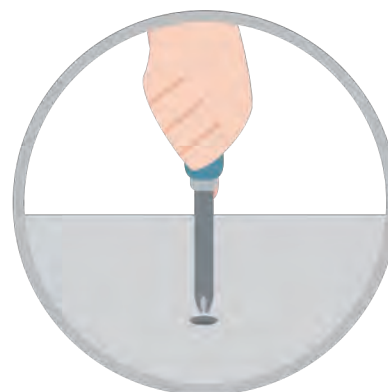

After two weeks, check and tighten any loose hardware and repeat again every six months thereafter.

IT IS THE USER'S RESPONSIBILITY TO MAINTAIN THE FURNITURE. THE HARDWARE MAY LOOSEN OVER TIME AND MAY CAUSE THE FURNITURE TO BE WOBBLY AND UNABLE TO SUPPORT ITS INTENDED WEIGHT CAPACITY. THIS MAY LEAD TO COLLAPSE AND MAY CAUSE SERIOUS INJURY.

E.KING BED

CM7302EK

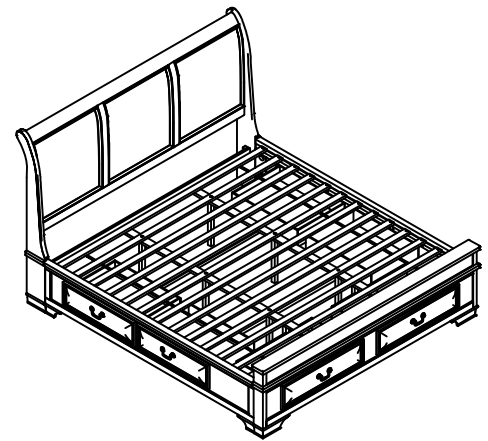

PARTS

#1 1pc

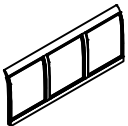

Headboard Panel

#2 2pcs



Headboard Leg (L&R)

#3 1pc



Headboard Support

#4 1pc

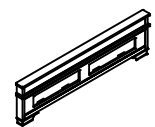

Storage Footboard

#5 1pc

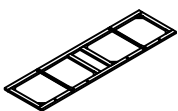

Bottom Frame for drawer of Footboard

#6 2pcs

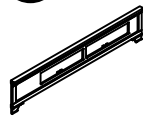

Side Rail (L&R)

#7 2pcs



Rail Drawer Support Slat

#8 2pcs

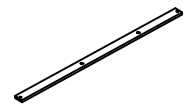

Center Slat

#9 4pcs

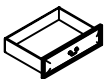

Drawer for Side rail

#10 2pcs

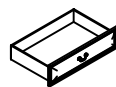

Drawer for Footboard

#11 6pcs

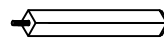

Long support leg
362x29x29mm

#12 2pcs

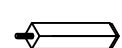

Short support leg
145x29x29mm

#13 2pcs



Storage Support Leg
195x29x29mm

#14 1pc



Bed Slat (13pcs)

HARDWARE

#A 8pcs



Bolt Ø5/16" x 1-3/4"

#E 4pcs



Flat Washer Ø1/4"

#J 8pcs



Threaded Stud
Ø5/16"x3-1/2"

#B 8pcs

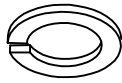

Lock Washer Ø5/16"

#F 1pc



Allen Wrench M4

#K 8pcs



Half Moon Ø5/16"

#C 8pcs

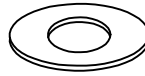

Flat Washer Ø5/16"

#G 4pcs



Wooden Dowel 10*40mm

#L 8pcs



Hex nut Ø5/16"

#D 4pcs



Bolt Ø1/4" x 1-1/2"

#H 30pcs

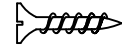

Screw #8 x 32mm



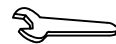



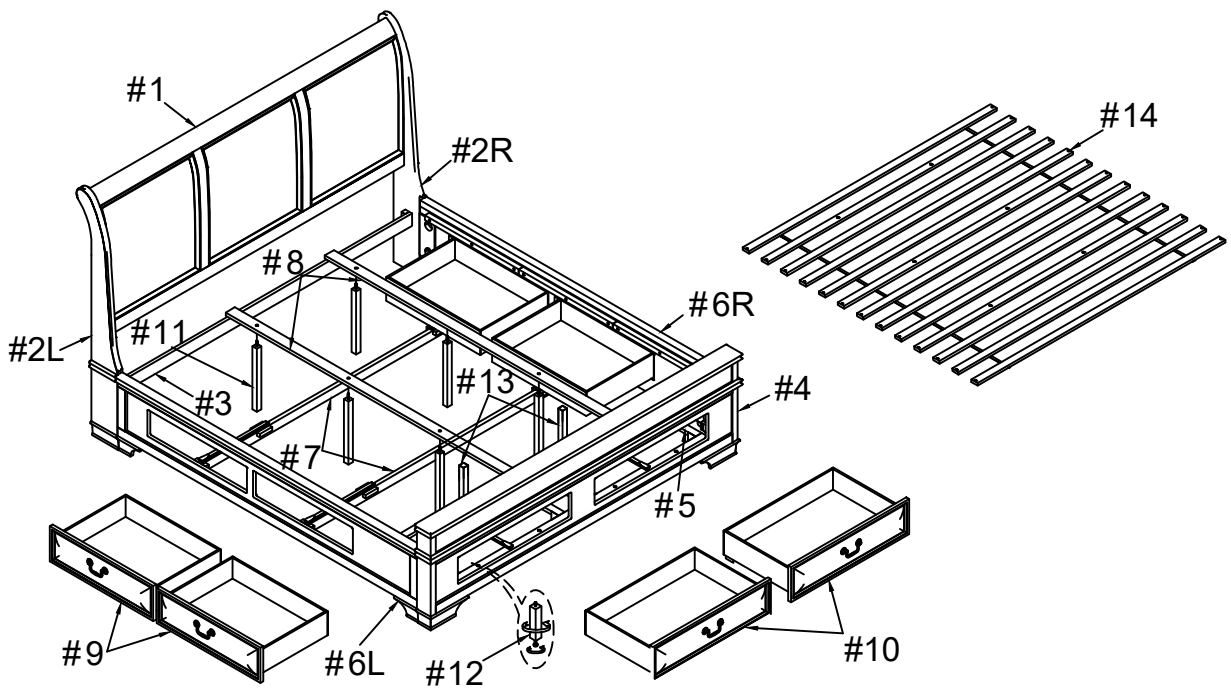

#M 1pc

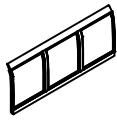
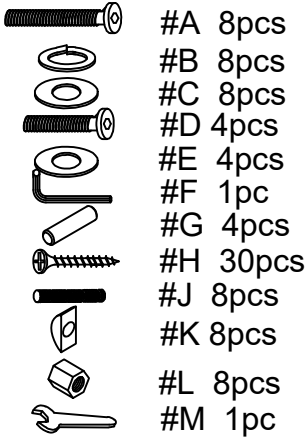
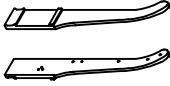

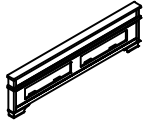
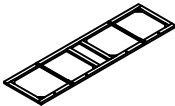
Wrench

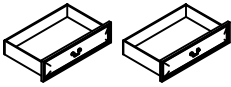
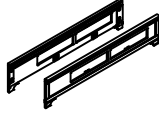

CM7302EK is packed in 5 cases

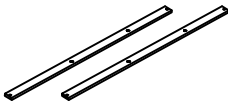
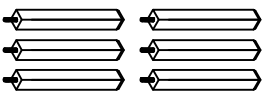
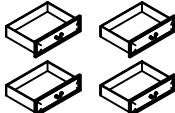
Carton	Disignation	Part	Hardware
CM7302EK-1	Headboard	#1 	
	Headboard Leg(L&R)	#2 	
	Headboard Support	#3 	
CM7302EK-2	Footboard	#4 	
	Bottom Frame for drawer of Footboard	#5 	
	Short support leg	#12 	
	Storage Support Leg	#13 	
	Bed Slat	#14 	
CM7302EK-3	Drawer for Footboard	#10 	
CM7302EK-4	Side Rail (L&R)	#6 	
	Rail Drawer Support Slat	#7 	
	Center Slat	#8 	
	Long support leg	#11 	
CM7302EK-5	Drawer for Side rail	#9 	

ASSEMBLY INSTRUCTIONS

1

- Part #1 x1pc
- Part #2 x2pcs
- Part #3 x1pc
- Hardware #A x8pcs
- Hardware #B x8pcs
- Hardware #C x8pcs
- Hardware #G x4pcs

Prepare 8 bolts assembly by inserting lock washer (#B) then flat washer (#C) onto bolts (#A). Attach dowels (#G) to the holes of the HB legs (#2R/L), then align HB legs (#2R/L) to the HB panel (#1) and HB support (#3). Secure by using bolts (#A).

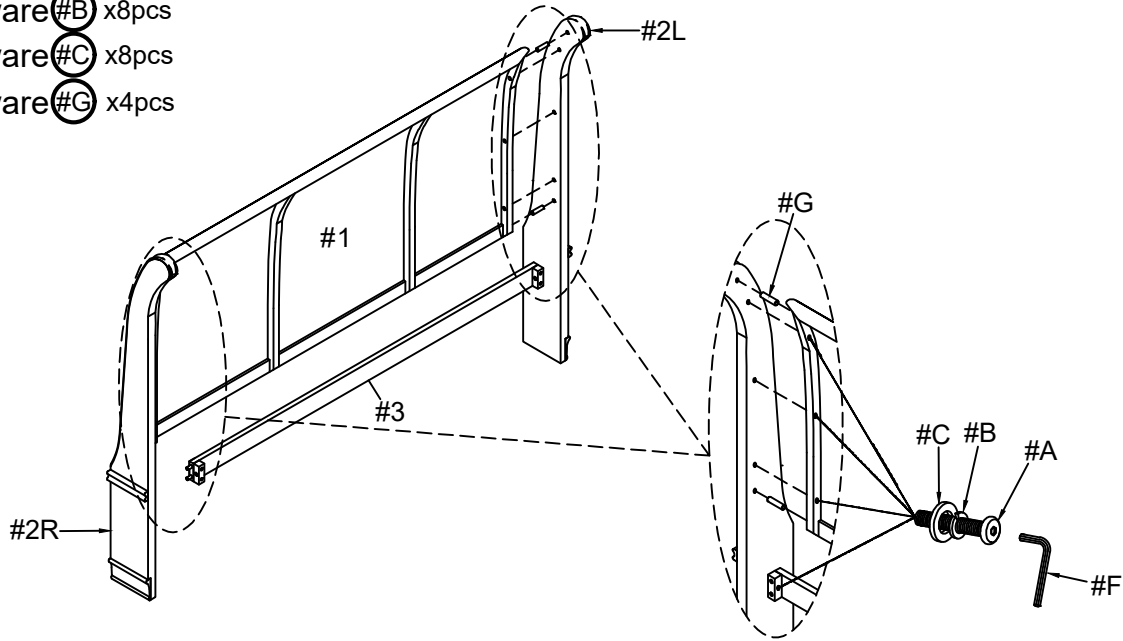

2

- Part #4 x1pc
- Part #5 x1pc
- Part #12 x2pcs
- Part #13 x2pcs
- Hardware #D x4pcs
- Hardware #E x4pcs

2) Attach support legs (#13) to the holes of the bottom frame (#5).

1) Align bottom frame (#5) to the holes of the footboard (#4), then secure by using bolts (#D) with washers (#E).

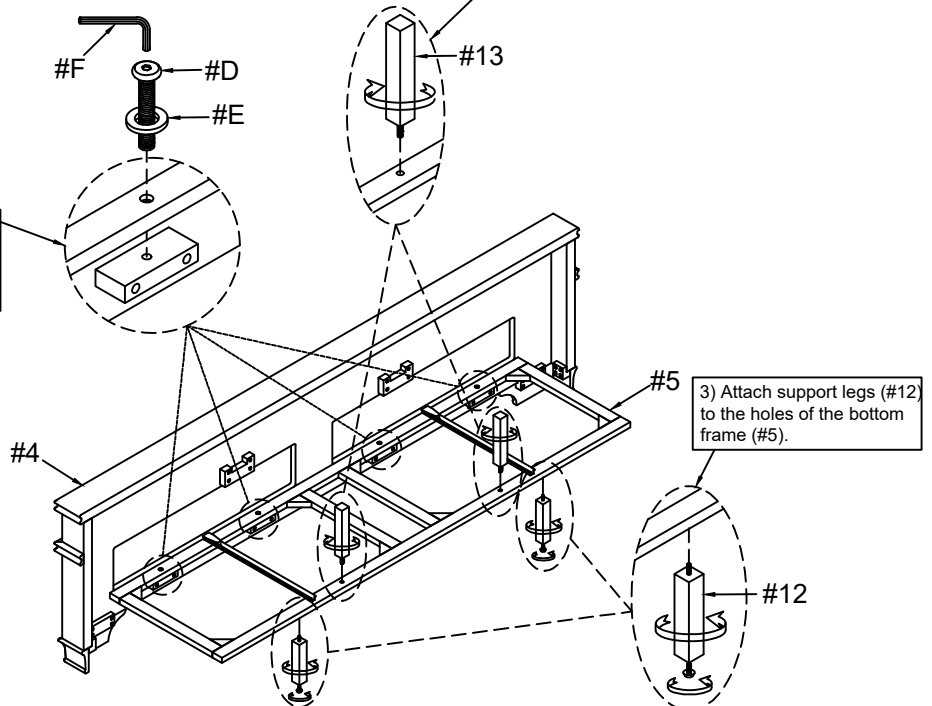

3) Attach support legs (#12) to the holes of the bottom frame (#5).

ASSEMBLY INSTRUCTIONS

3

- Part #6 x2pcs
- Hardware #J x8pcs
- Hardware #K x8pcs
- Hardware #L x8pcs

Attach threaded studs (#J) to the holes of the headboard (#1) and footboard (#4), then align side rails (#6R/L) to the threaded studs (#J). Secure by using washer (#K) with hex nut (#L).

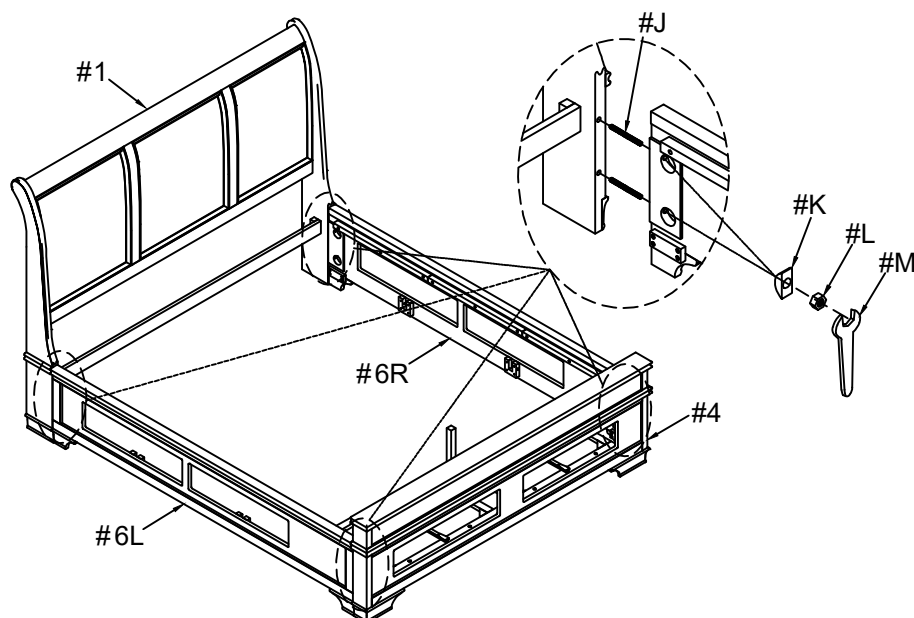

4

- Part #7 x2pcs
- Hardware #H x4pcs

Align rail drawer support slats (#7) to the side rails (#6R/L), then secure by using screws (#H).

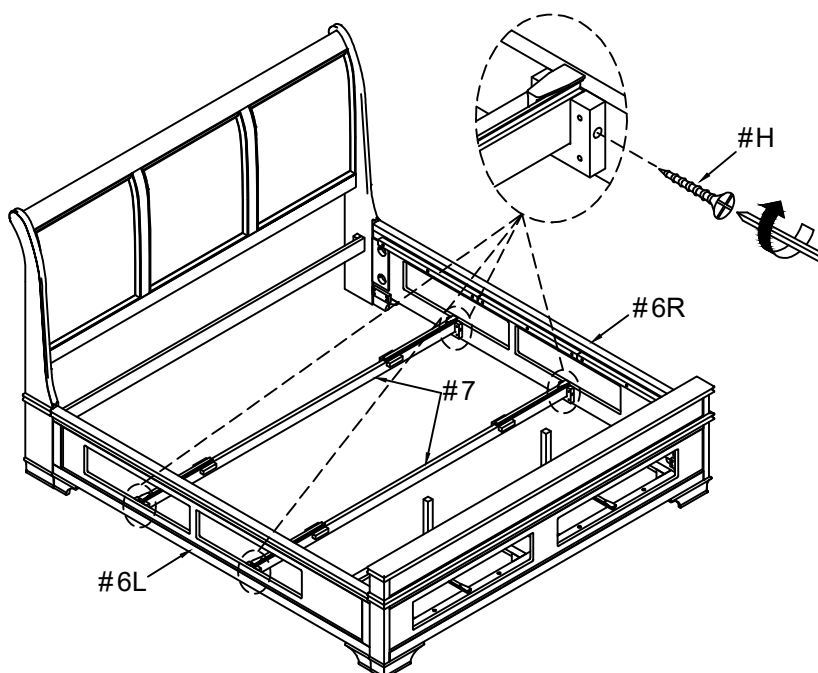

ASSEMBLY INSTRUCTIONS

5

- Part #8 x2pcs
- Part #11 x6pcs
- Part #14 x1pc

Align and attach support legs (#11) to the holes of the center slats (#8) and bed slats (#14). Adjust the leveler on the support legs (#11) according to ground level.

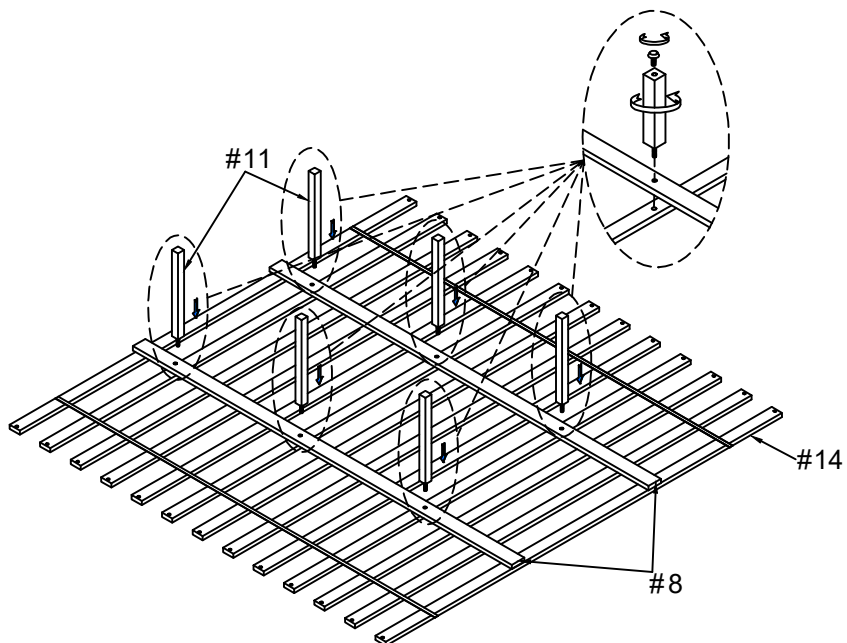

6

- Hardware #H x26pcs

Place bed slats (#14) to the side rails, then secure by using screws (#H).

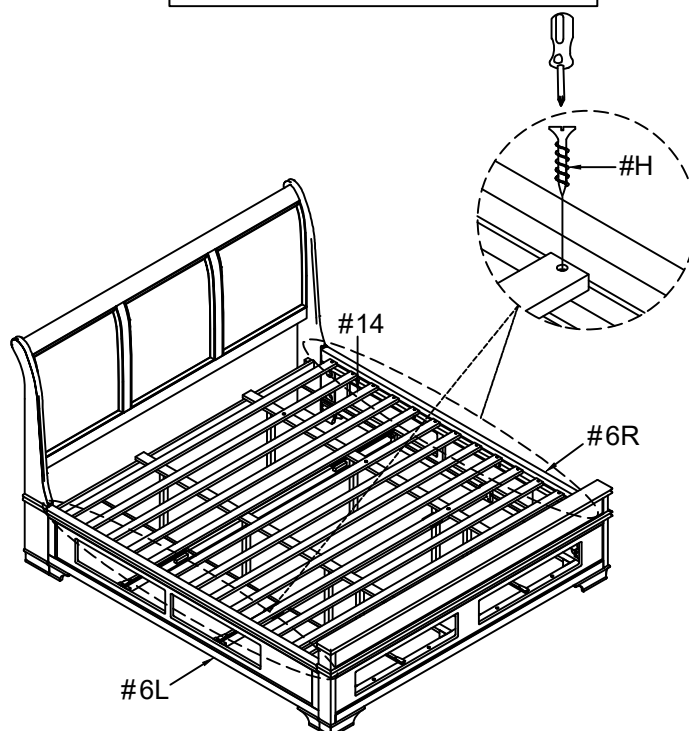

ASSEMBLY INSTRUCTIONS

7

Part #9 x4pcs

Part #10 x2pcs

Attach drawers (#9,10) to the drawer slat rails.

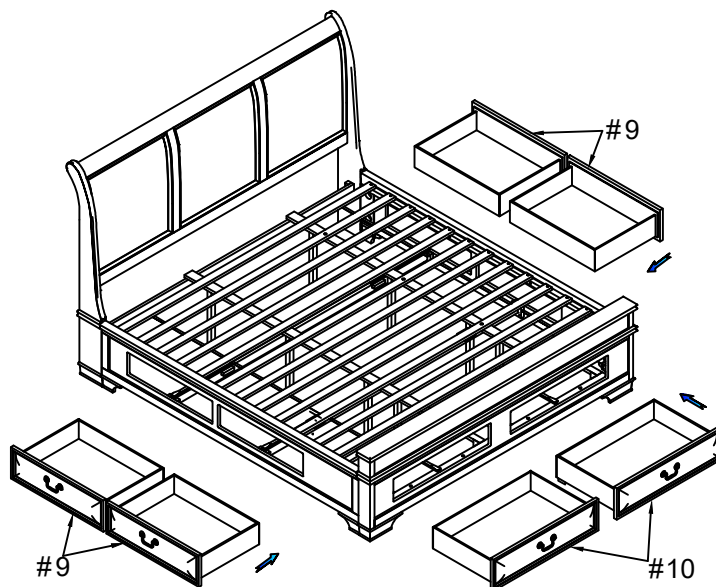

8

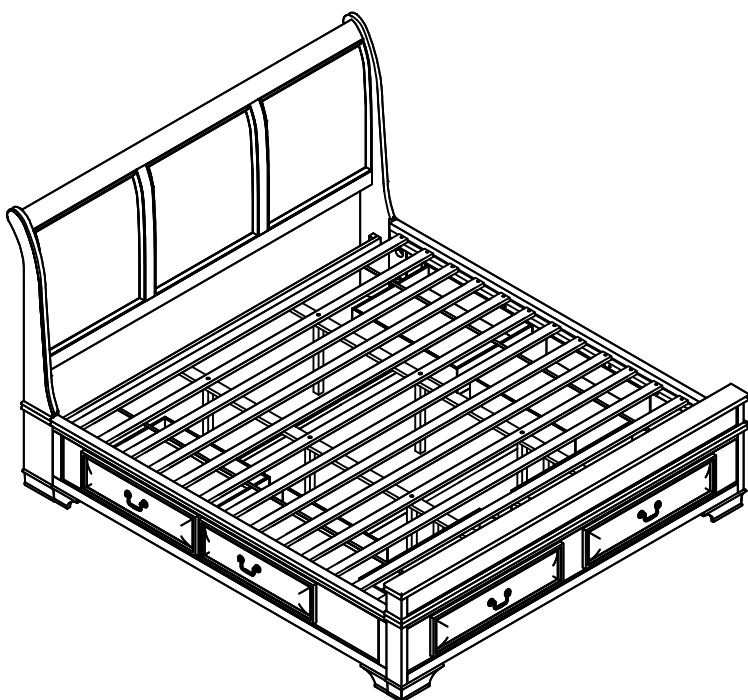

ASSEMBLY COMPLETED



Please ensure the furniture rests on an even and flat surface. If the product wobbles or feels loose, double-check all bolts and/or screws are properly tightened and secured.



Keep this handy!

Please retain this instruction manual and any order-related information for future reference.



Lift, don't drag!

To avoid damage to product please always LIFT the product when transporting or adjusting the placement.