

ASSEMBLY INSTRUCTIONS

MODEL #

CM7195CK

Questions?

GIVE US CALL: 1-888-980-5122
MON-FRI 8:30AM - 5:30PM (PST)

TOOLS REQUIRED



Allen Wrench

(Included)



Phillips Screwdriver

(Not Included)

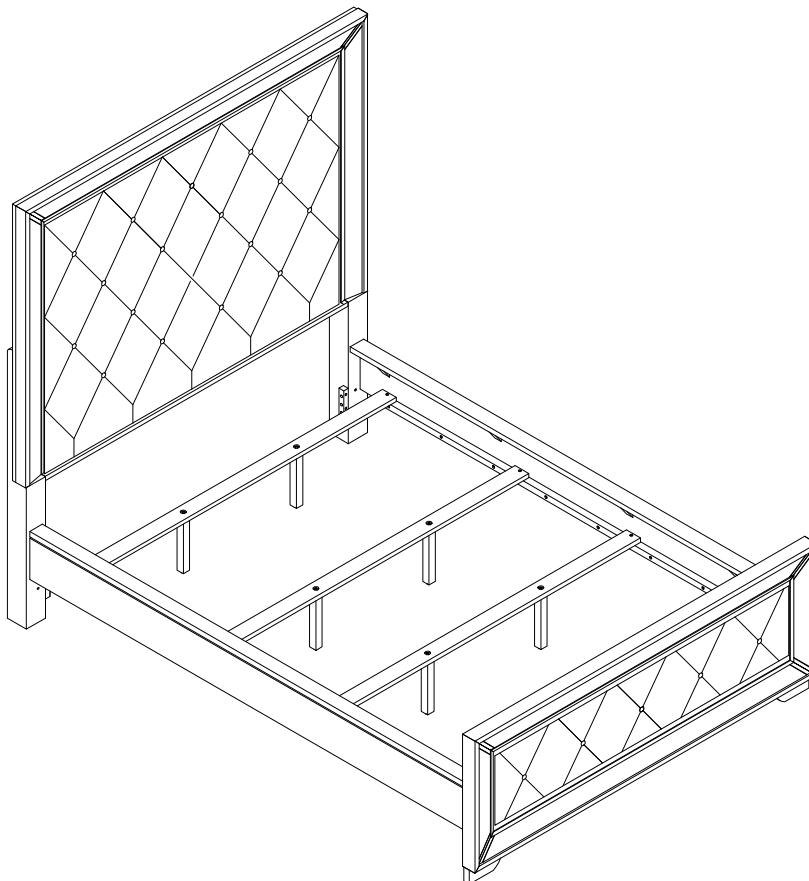

3 - People
Recommended

ASSEMBLY RATING



EASY —————> DIFFICULT

The Assembly Rating is a 5-point system showing the level of effort needed to assemble a specific product.



FOA Intro

Thank you for your purchase!

We hope you enjoy this new addition to your home for many years to come.

Our commitment to providing quality products does not simply end when you purchase our product. We fully stand behind our products from start to finish. Our customer service department is available Monday – Friday 8:30 AM – 5:30 PM Pacific and can help with assembly questions as well as, if necessary, replacing damaged or missing parts. To help expedite our service, please have these assembly instructions readily available, along with your order receipt.

 **Consumer Hotline**
Toll-Free 1-888-980-5122

 **WEBSITE**
www.foagroup.com

    foagroup

 **Monday to Friday**
8:30AM- 5:30PM (PST)

 **E-MAIL**
cs.ec@foagroup.com

 FurnitureOfAmerica

CHECK BEFORE STARTING

Are you missing anything?

Double-check all parts, hardware and accessories listed on Page 6 are accounted for.

Should we send any replacements?

Are there any irregularities or flaws in the parts? We can send replacements!

Check out our Quick Tips!

We recommend reviewing the pre-assembly handouts. Even experts need a refresher now and then!

Prep Time!

Please review the assembly instructions and all diagrams prior to assembling. Arrange parts as recommended on Page 7 and group identical hardware together to make assembling easier.

PRE ASSEMBLY INTRODUCTION

We understand building ready-to-assemble furniture can be a challenging experience for some. To help avoid confusion, we have provided some helpful tips that may speed up the process.

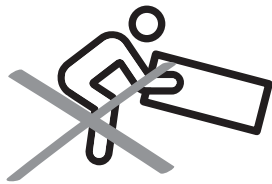

Teamwork

ALWAYS have at least two people to help with transporting and assembling the product to avoid potential injury and/or damage.

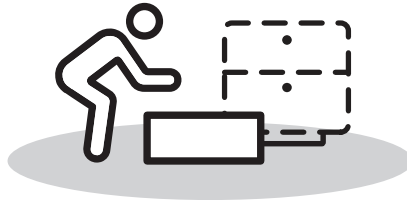
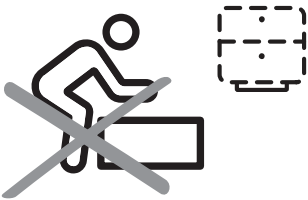

Suitable Location

Assembling near the area of the intended location is highly recommended.



Sufficient Space

Make sure you have enough space to move around during the assembly.



Avoid Scratches

Use cardboard, blankets or a carpeted area while assembling furniture to prevent scratches.

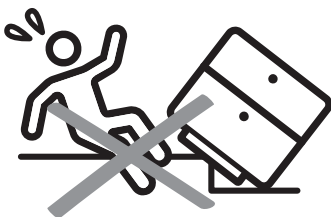

Flat Surface

Make sure the furniture rests on a flat and level surface with each leg evenly touching the floor.

ASSEMBLY AND CARE ADVICE



FAILURE TO FOLLOW THE GUIDELINES BELOW MAY RESULT IN INJURY AND/OR PROPERTY DAMAGE.



Position each part correctly and insert screws or bolts into their respective holes.

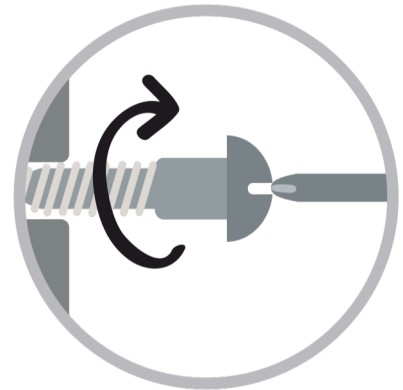

Turn clockwise to tighten and only tighten when step is completed or when instructed to do so.



Use the appropriate hand tools or power tools for assembly. Select steps, such as tightening screws and/or bolts, may require hand tools to avoid causing damage during assembly.



Save the instructions and store any supplied tools for later maintenance.



After two weeks, check and tighten any loose hardware and repeat again every six months thereafter.

IT IS THE USER'S RESPONSIBILITY TO MAINTAIN THE FURNITURE. THE HARDWARE MAY LOOSEN OVER TIME AND MAY CAUSE THE FURNITURE TO BE WOBBLY AND UNABLE TO SUPPORT ITS INTENDED WEIGHT CAPACITY. THIS MAY LEAD TO COLLAPSE AND MAY CAUSE SERIOUS INJURY.

BED

CM7195CK

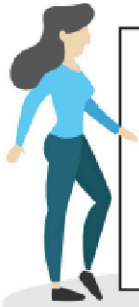

- Please keep instructions for future reference.
- Check the quantity and irregularity of parts and hardware before you start.

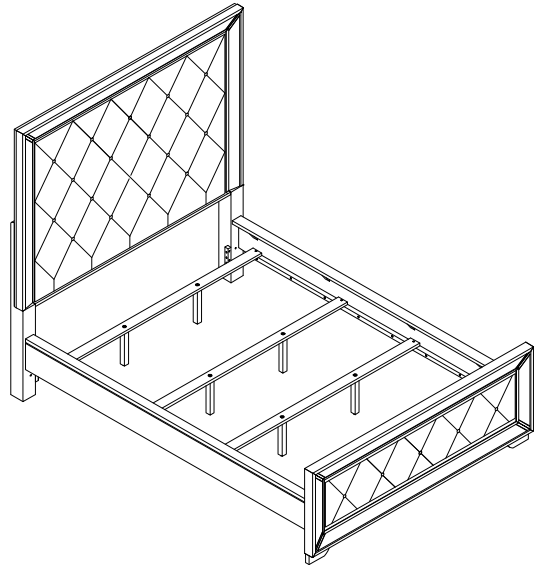

PARTS

#1 1pc

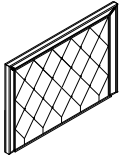

Headboard

#2 2pcs

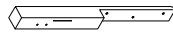

Headboard leg
(L-R)

#3 1pcs

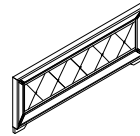

Footboard

#4 2pcs



Bed Side Rails

#5 4pcs

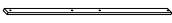

Slats

#6 8pcs

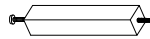

Slats Support leg
220x30x30mm

HARDWARE

#A 6pcs



Bolt
Ø5/16"x1-3/8"

#B 6pcs



Lock Washer
Ø5/16"

#C 6pcs



Flat Washer
Ø5/16"

#D 1pc



Allen Key

#E 2pcs



Metal Bracket
30mmx18mm

#F 4pcs



Bolt
Ø1/4"x5/8"

#G 4pcs



Lock Washer
Ø1/4"

#H 4pcs







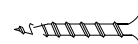



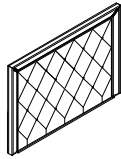

Flat Washer
Ø1/4"

#K 8pcs

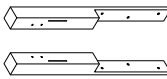
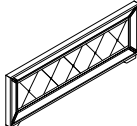

Screw
#4x32mm

CM7195CK is packed in 3 cases

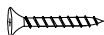
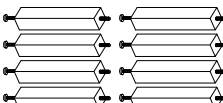
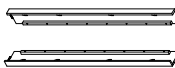
Carton	Disignation	Part	Hardware
CM7195CK-HB	Headboard Panel	#1 	 #A x 6pcs  #B x 6pcs  #C x 6pcs  #D x 1pc  #E x 2pcs  #F x 4pcs  #G x 4pcs  #H x 4pcs
	Headboard leg (L-R)	#2 	
CM7195CK-FB	Footboard Panel	#3 	
	Slats	#5 	 #K x 8pcs
	Slats Surpport legs	#6 	
CM7195CK-R	Side Rails	#4 	

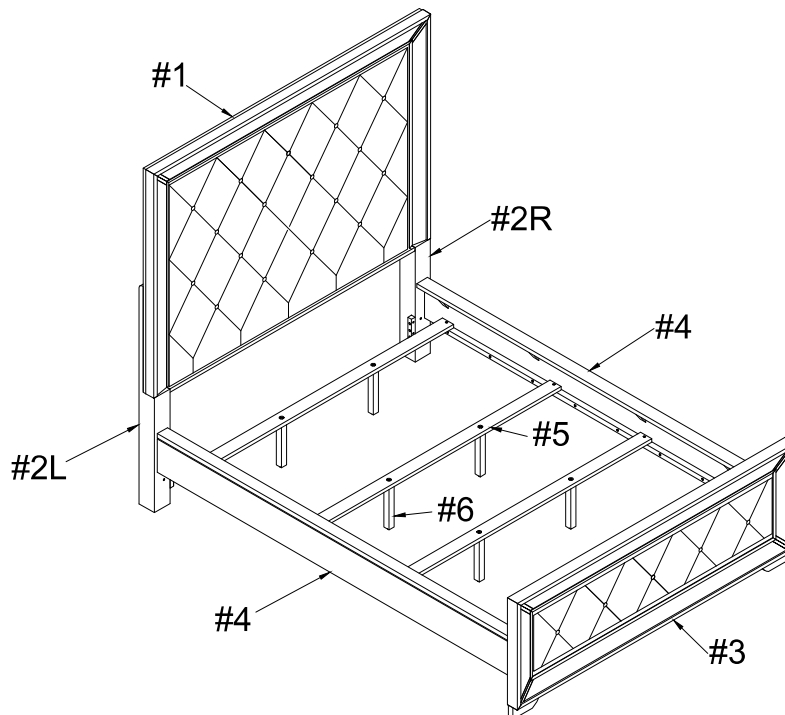

ASSEMBLY INSTRUCTIONS

1

- Part #1 x1pc
- Part #2 x2pcs
- Hardware #A x6pcs
- Hardware #B x6pcs
- Hardware #C x6pcs

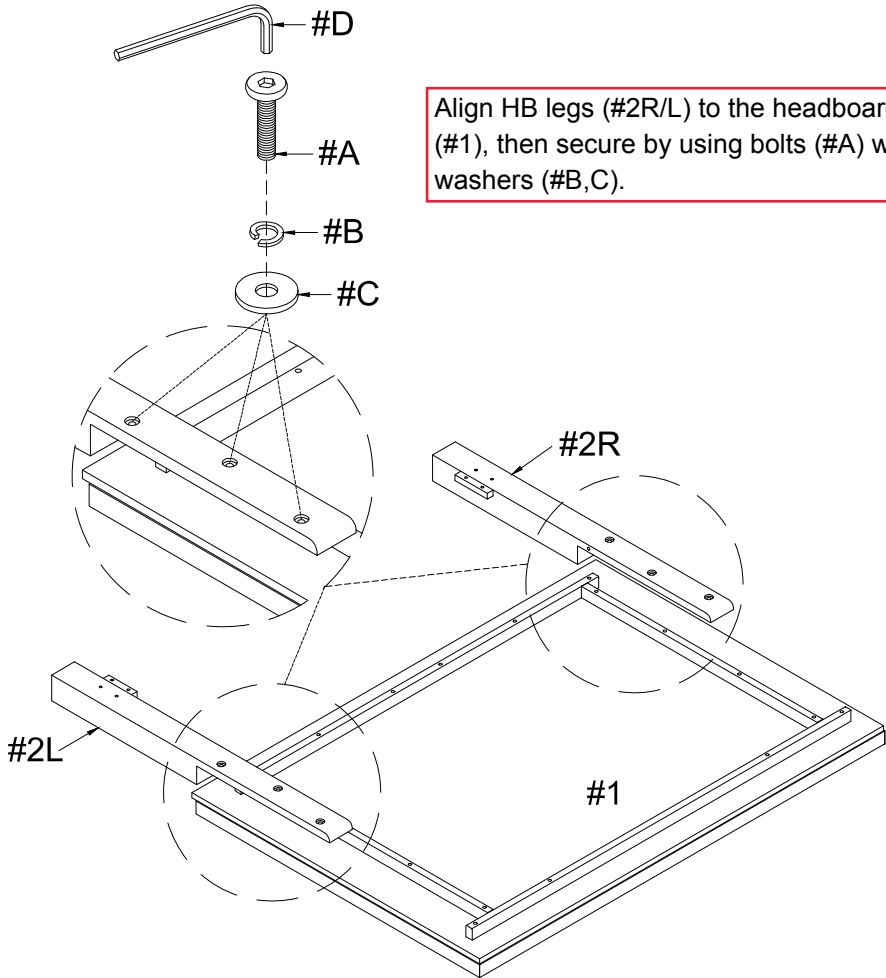

Align HB legs (#2R/L) to the headboard (#1), then secure by using bolts (#A) with washers (#B,C).

2

- Hardware #E x2pcs
- Hardware #F x4pcs
- Hardware #G x4pcs
- Hardware #H x4pcs

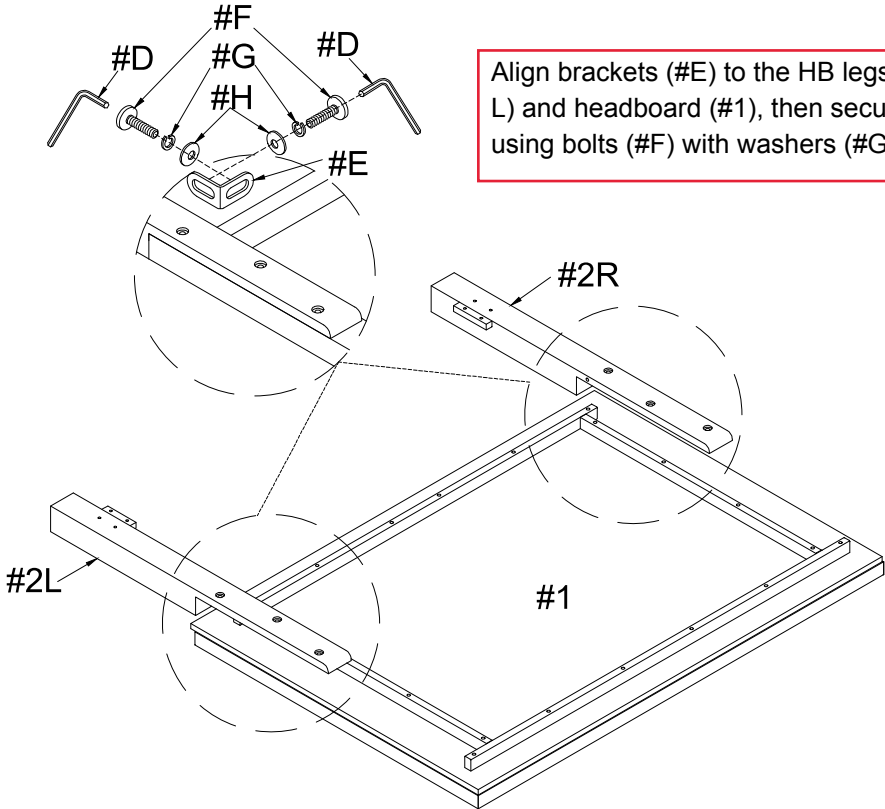

Align brackets (#E) to the HB legs (#2R/L) and headboard (#1), then secure by using bolts (#F) with washers (#G,H).

ASSEMBLY INSTRUCTIONS

Align and attach the side rails (#4) to the headboard (#1) and footboard (#3).

3

Part #3 x1pc
Part #4 x2pcs

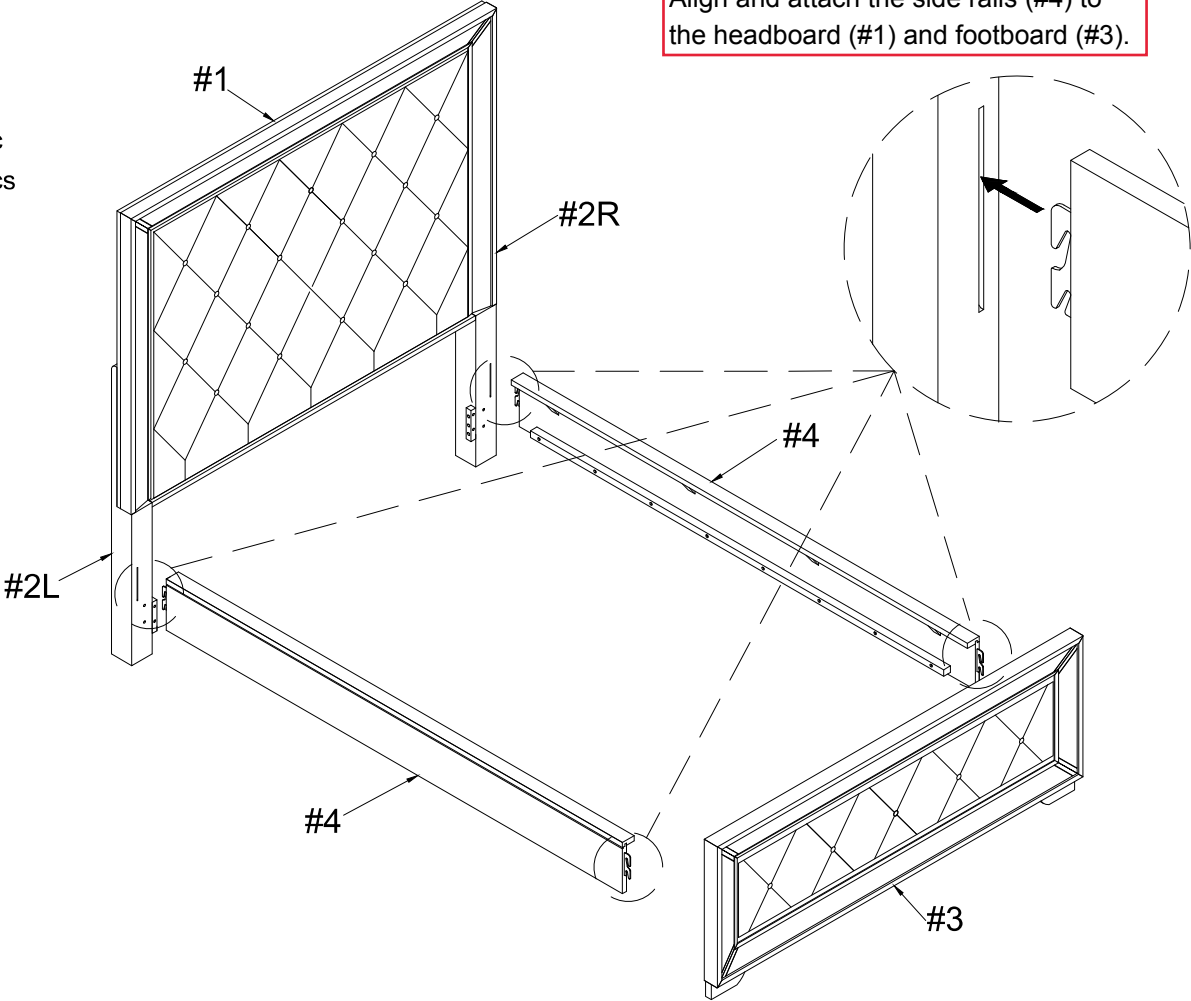

4

Part #5 x1pc
Part #6 x2pcs

Attach support legs (#6) to the slats (#5). Adjust levelers on the support legs (#6) according to the ground level.

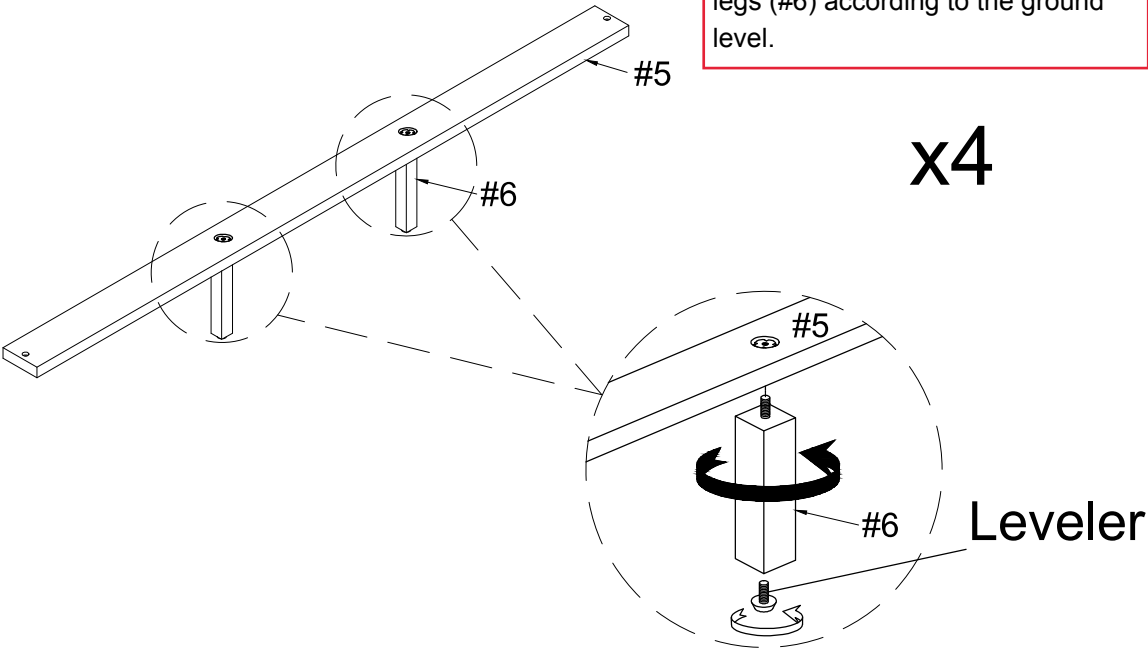

ASSEMBLY INSTRUCTIONS

5

Hardware  x8pcs

Align slats to the side rails, then secure by using screws (#K).

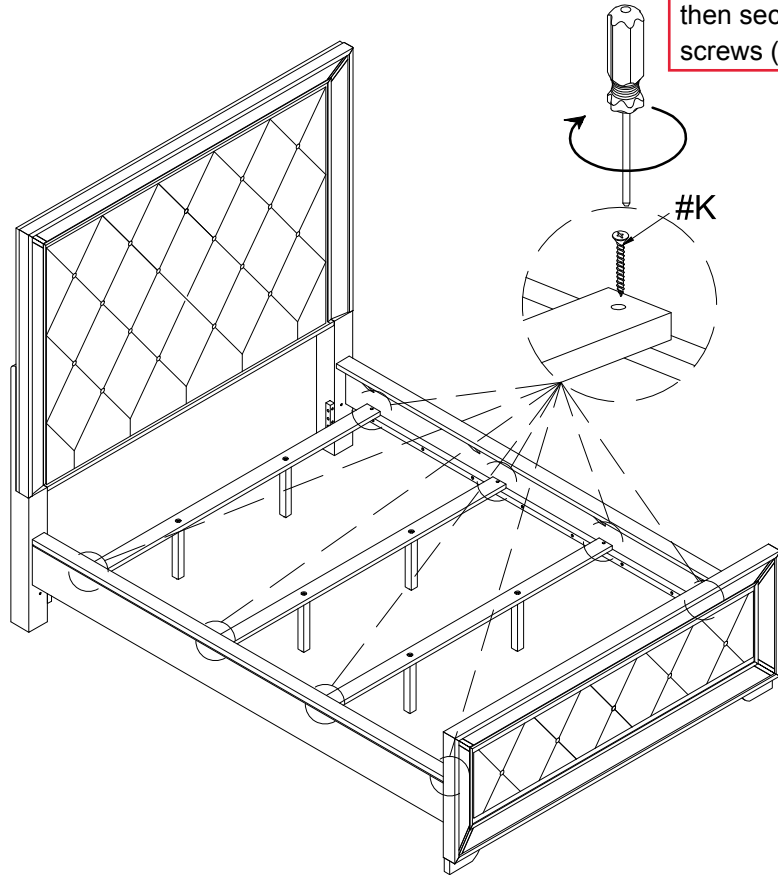

6

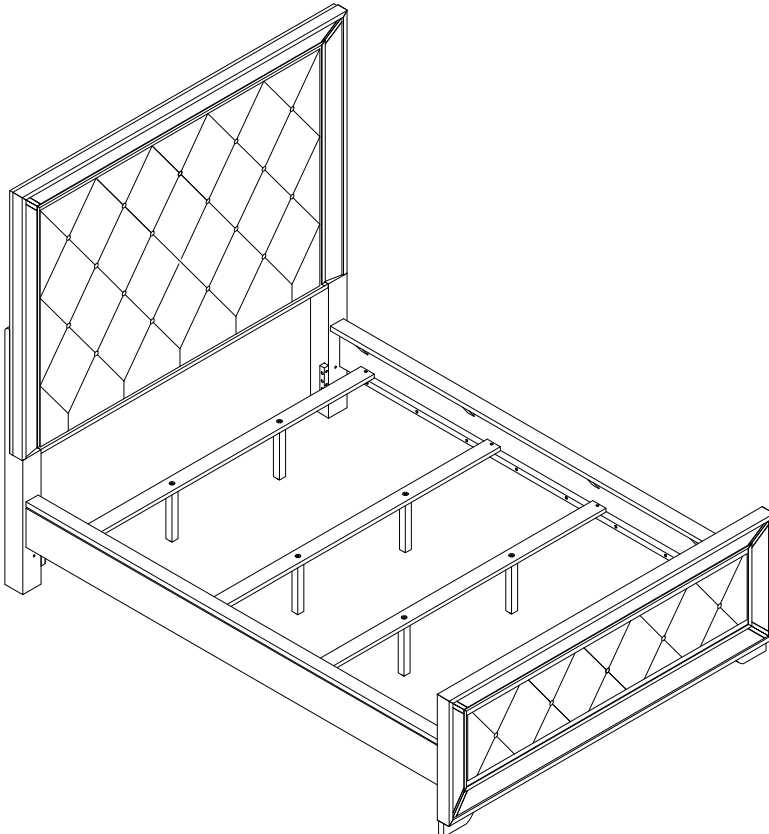

ASSEMBLY COMPLETED



Please ensure the furniture rests on an even and flat surface. If the product wobbles or feels loose, double-check all bolts and/or screws are properly tightened and secured.



Keep this handy!

Please retain this instruction manual and any order-related information for future reference.



Lift, don't drag!

To avoid damage to product please always LIFT the product when transporting or adjusting the placement.