

Furniture of America[®]

Assembly Instructions

For more information contact our team: service.ec@foagroup.com

CM5901TV-60/72

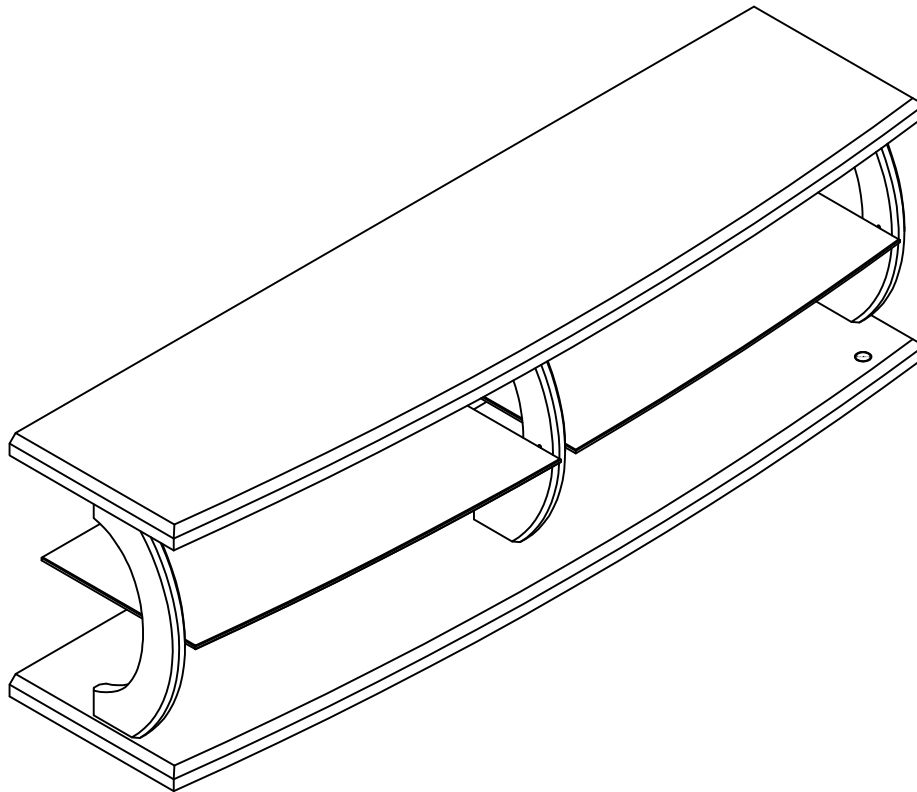

ASSEMBLY RATING

The Assembly Rating is a 5-point system that shows the degree of effort needed in assembling a specific product (with 1 being easy and 5 being difficult). For some products, two persons are recommended.

EASY  DIFFICULT

Tools Required For Assembly:

Allen Wrench

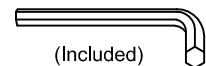

(Included)

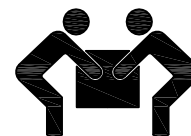

2 PERSONS RECOMMENDED

ASSEMBLY & CARE ADVICE

FOR YOUR FURNITURE TO LAST, CORRECT ASSEMBLY AND PROPER MAINTENANCE ARE NECESSARY. PLEASE FOLLOW THE INFORMATION PROVIDED BELOW TO FULLY ENJOY YOUR FURNITURE.

BASIC ASSEMBLY TECHNIQUES



1 When lock or spring washer is used in an assembly, please make sure the lock or spring washer is placed between the larger flat washer and the head of the screw or bolt.



2 Position each part correctly and insert screws or bolts into their respective holes by hand tighten or using the proper hand tool. Only tighten when step is completed or when instructed to do so.

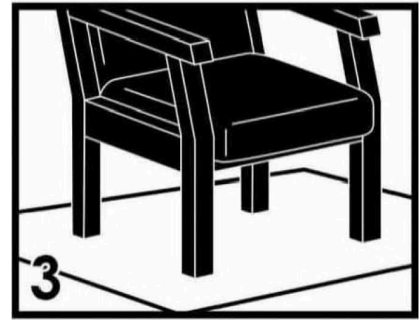

3 Use cardboard or carpet area when assembling furniture to prevent scratches. Make sure the furniture rests on a flat and level surface with each leg evenly touching the floor.



4 Some furniture comes with height adjustment knobs underneath each leg. To lower or to raise each leg, you need to turn clockwise or counterclockwise, respectively.

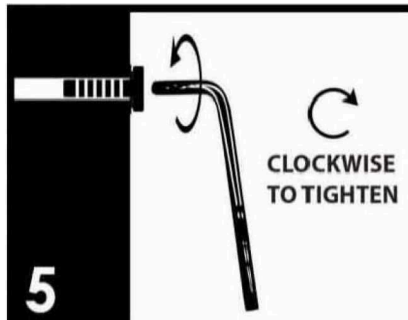

5 Make sure all parts are properly aligned, then use the appropriate hand tool to completely tighten the bolts or screws. Do not use power tools and do not overtighten.

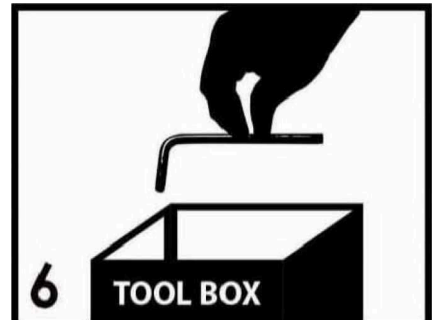

6 Save the instructions and store the Allen wrench or any supplied tool for later maintenance. After two weeks, check and tighten any loose hardware and repeat again every six months thereafter.

IT IS THE USER'S RESPONSIBILITY TO MAINTAIN THE FURNITURE. THE HARDWARE MAY LOOSEN OVER TIME AND MAY CAUSE THE FURNITURE TO BE WOBBLY AND UNABLE TO SUPPORT ITS INTENDED WEIGHT CAPACITY. THIS MAY LEAD TO COLLAPSE AND MAY CAUSE SERIOUS INJURY.

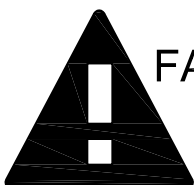

FAILURE TO FOLLOW THE GUIDELINES ABOVE MAY RESULT IN INJURY AND/OR PROPERTY DAMAGE.

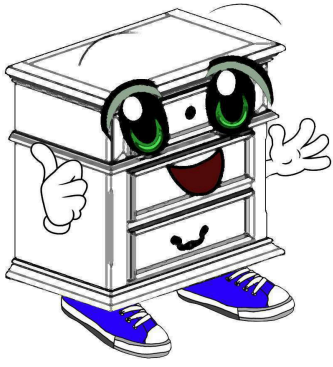

Before you begin, please read Page 2 of "Assembly and Care Advice".

And remember, do not tighten until each step is completed or instructed.

Parts List

Hardware List

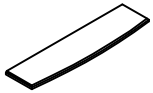

#1 x 1pc
TOP Panel



#A x 14pcs
Bolt Ø1/4"X 1-3/4"



#2 x 2pcs
Side Leg (L & R)



#B x 18pcs
Bolt Ø1/4"X 3/4"



#3 x 1pc
Center Leg



#C x 14pcs
Lock Washer



#4 x 2pcs
Back Panel



#D x 14pcs
Flat Washer

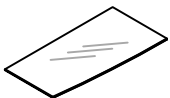

#5 x 2pcs
Glass Shelf



#E x 1pc
Allen Wrench

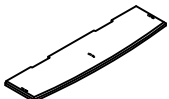

#6 x 1pc
Bottom Panel



#F x 3pcs
Bracket

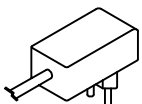

#7 x 1pc
Adapter



#G x 8pcs
Glass Shelf Support



#1

Align bracket (#F) to the holes of the side and center legs (#2,3). Secure by using bolts (#B).

#B x 6pcs

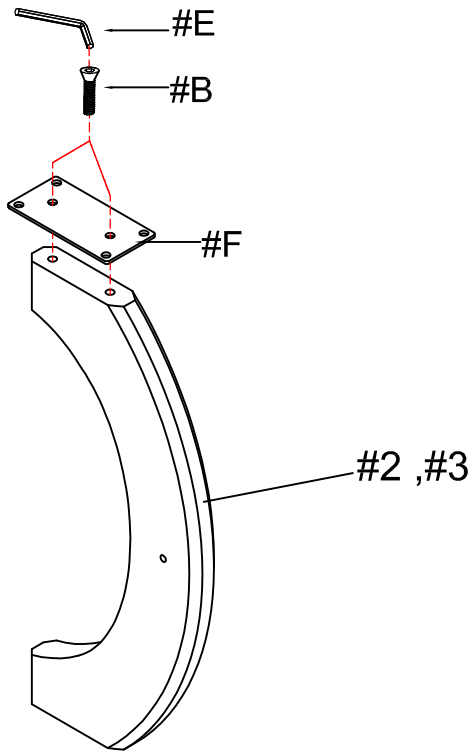

#2

2) Align side legs (#2) and center legs (#3) to the holes of the top panel (#1), then secure by using bolts (#B).

#A x 4pcs
#B x 12pcs
#C x 4pcs
#D x 4pcs

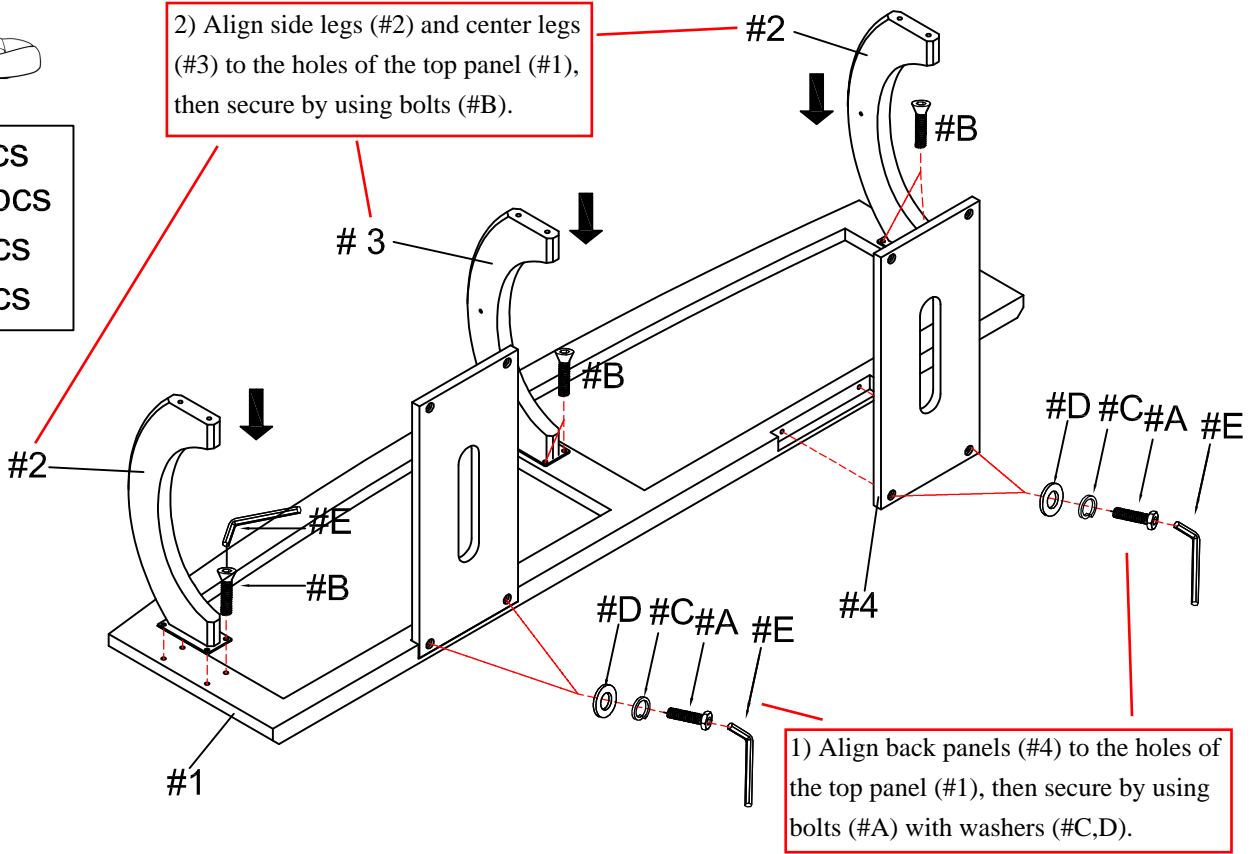

1) Align back panels (#4) to the holes of the top panel (#1), then secure by using bolts (#A) with washers (#C,D).



#3

2) Secure side/center legs (#2,3) to the holes of the bottom panel (#6), then secure by using bolts (#A) with washers (#C,D).

#A x 10pcs
#C x 10pcs
#D x 10pcs

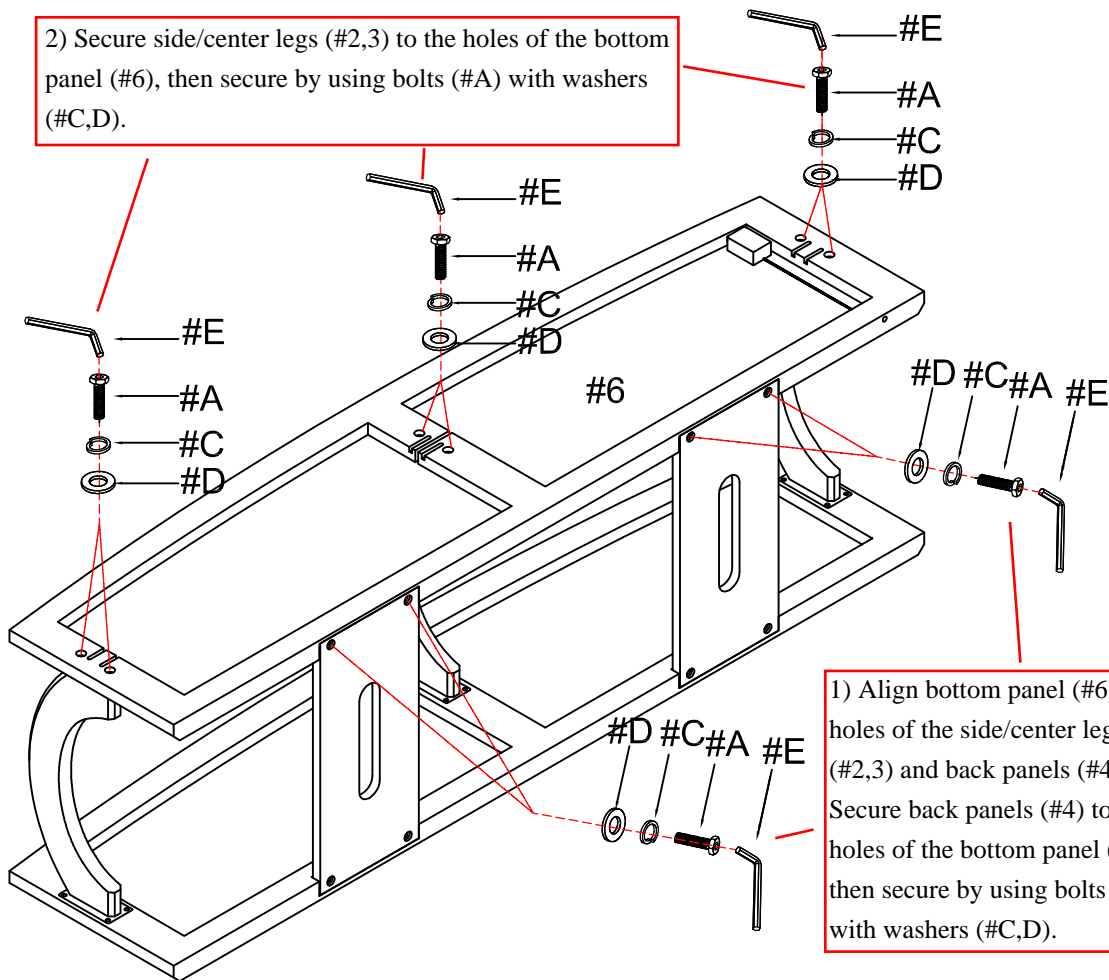

1) Align bottom panel (#6) to the holes of the side/center legs (#2,3) and back panels (#4). Secure back panels (#4) to the holes of the bottom panel (#6), then secure by using bolts (#A) with washers (#C,D).



#4

Insert glass shelf supports (#G) to the holes of the side/center legs (#2,3) and back panels (#4), then insert glass shelves (#5) through the shelf supports (#G).

#G x 8pcs

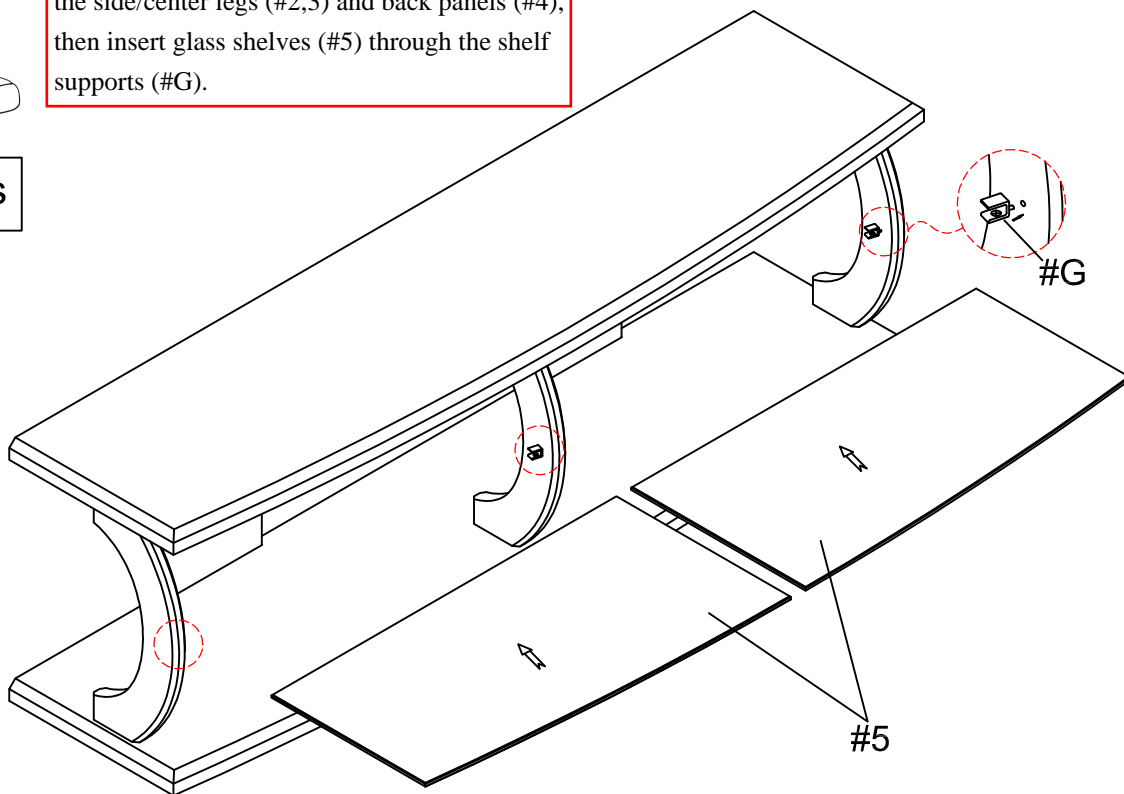

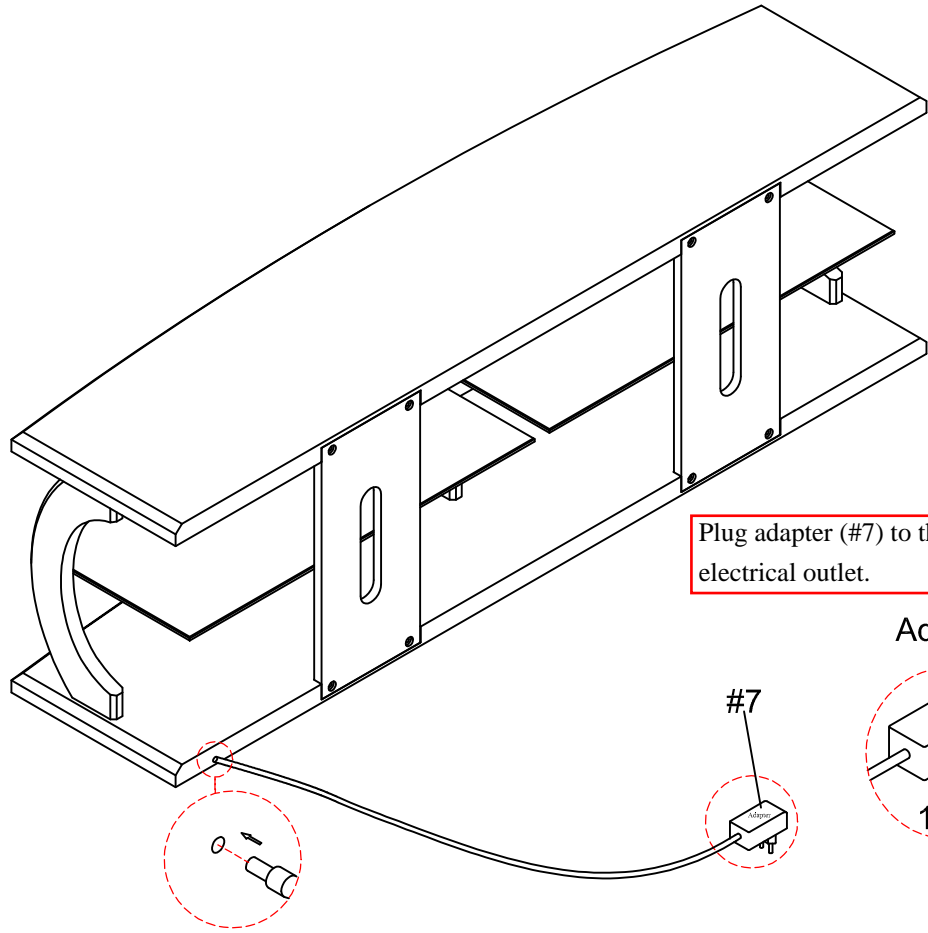

Plug adapter (#7) to the TV-stand and electrical outlet.

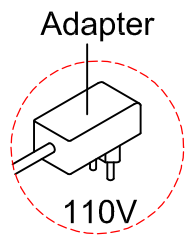

Screw the shelf supports (#G) to tighten and secure the glass shelves.

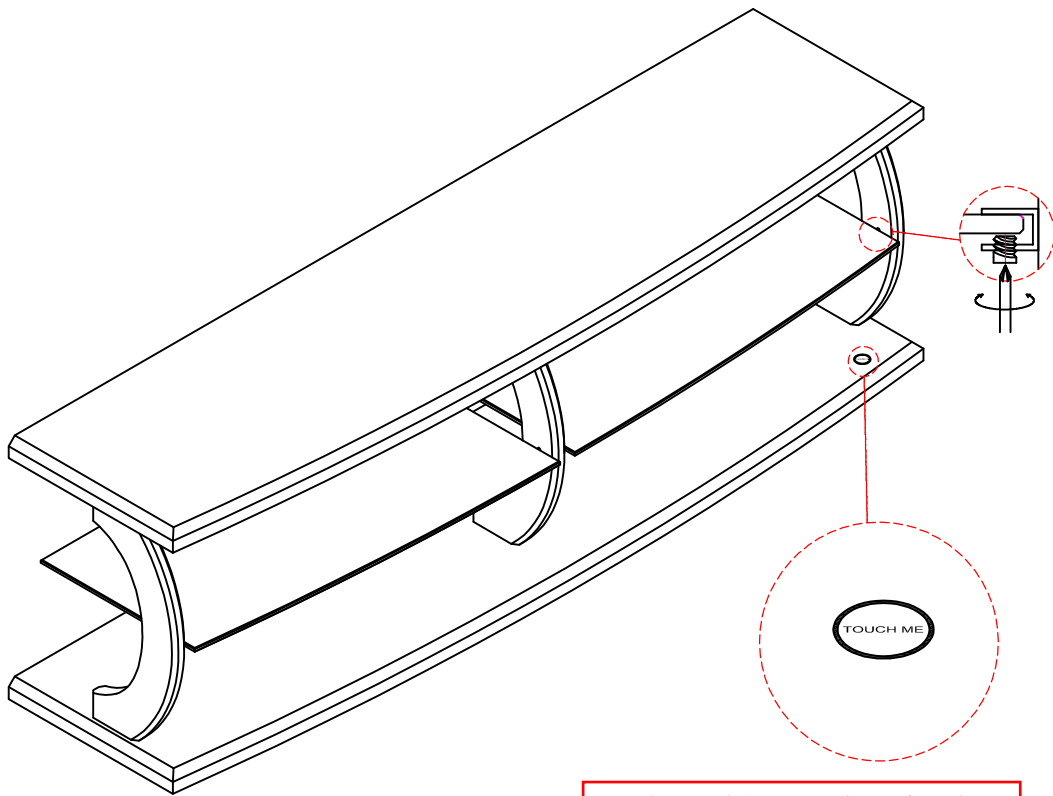

Touch me sticker to activate functions.