

Assembly Instructions

CM4401S

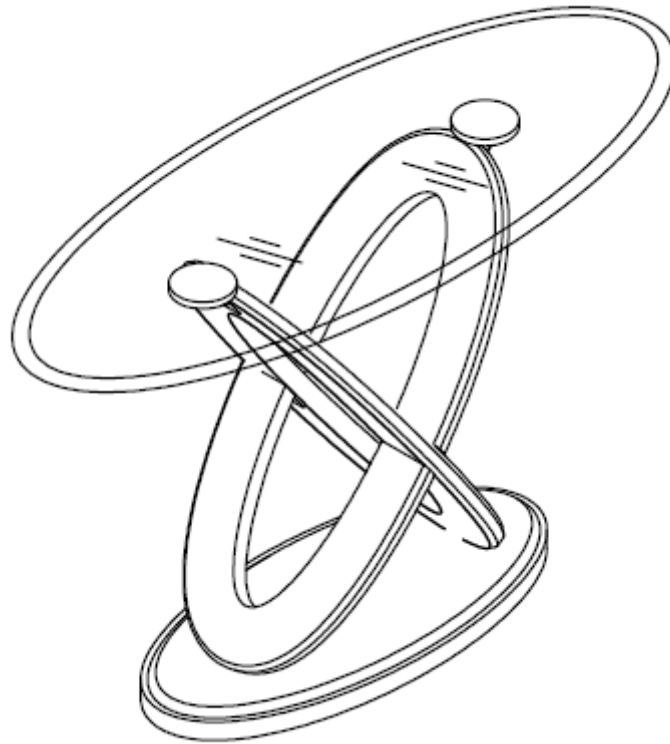

ASSEMBLY RATING

The Assembly Rating is a 5-point system that shows the degree of effort needed in assembling a specific product (with 1 being easy and 5 being difficult). For some products, two persons are recommended.

EASY  DIFFICULT

Tools Required for Assembly:

Allen Wrench



(Included)



2 PERSONS RECOMMENDED



Furniture of America™

E-commerce Division - Enitial Lab

Thank you for your purchase!

We hope you will enjoy your new product for many years to come. Our commitment to providing quality products does not simply end when a purchase is made. We stand behind our products and will provide any support needed in order for you to fully enjoy your purchase. Your satisfaction is the greatest recognition we could have.

Because we value your trust in our company, we will do our best to meet your service expectations. Should you have any assembly related questions, parts replacement requests, comments or suggestions, please feel free to contact us any time. To help expedite the service, please have the assembly instructions available, along with your order receipt.



www.foagroup.com



cs.ec@foagroup.com



Toll-Free 1-888-980-5122 or 1-626-363-9311



1-626-270-4451



Monday to Friday 8:30 a.m. to 5:30 p.m. (PST)



<https://twitter.com/foagroup>

<http://instagram.com/foagroup#>

<http://www.pinterest.com/foagroup/>

<https://www.youtube.com/user/FurnitureOfAmerica>

ASSEMBLY & CARE ADVICE

FOR YOUR FURNITURE TO LAST, CORRECT ASSEMBLY AND PROPER MAINTENANCE ARE NECESSARY. PLEASE FOLLOW THE INFORMATION PROVIDED BELOW TO FULLY ENJOY YOUR FURNITURE.

BASIC ASSEMBLY TECHNIQUES

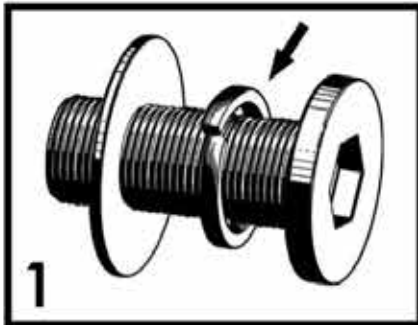

1
When lock or spring washer is used in an assembly, please make sure the lock or spring washer is placed between the larger flat washer and the head of the screw or bolt.

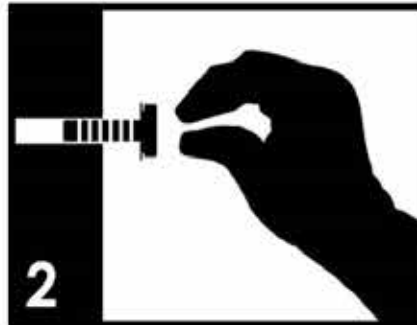

2
Position each part correctly and insert screws or bolts into their respective holes by hand tighten or using the proper hand tool. Only tighten when step is completed or when instructed to do so.



3
Use cardboard or carpet area when assembling furniture to prevent scratches. Make sure the furniture rests on a flat and level surface with each leg evenly touching the floor.

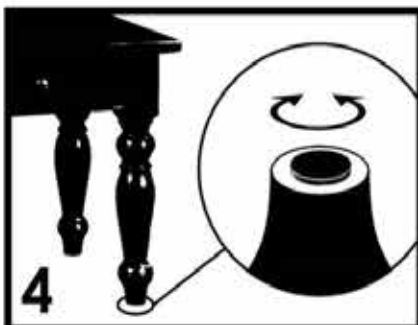

4
Some furniture comes with height adjustment knobs underneath each leg. To lower or to raise each leg, you need to turn clockwise or counterclockwise, respectively.

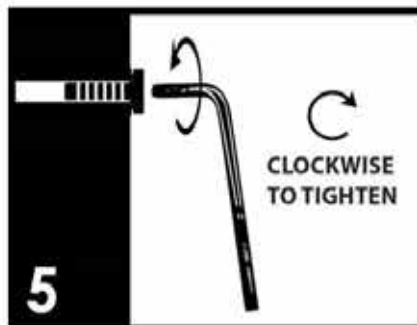

5
Make sure all parts are properly aligned, then use the appropriate hand tool to completely tighten the bolts or screws. Do not use power tools and do not overtighten.

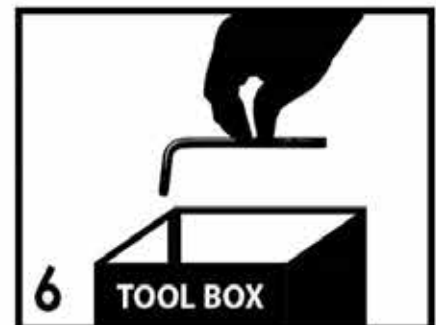

6
Save the instructions and store the Allen wrench or any supplied tool for later maintenance. After two weeks, check and tighten any loose hardware and repeat again every six months thereafter.

IT IS THE USER'S RESPONSIBILITY TO MAINTAIN THE FURNITURE. THE HARDWARE MAY LOOSEN OVER TIME AND MAY CAUSE THE FURNITURE TO BE WOBBLY AND UNABLE TO SUPPORT ITS INTENDED WEIGHT CAPACITY. THIS MAY LEAD TO COLLAPSE AND MAY CAUSE SERIOUS INJURY.



FAILURE TO FOLLOW THE GUIDELINES ABOVE MAY RESULT IN INJURY AND/OR PROPERTY DAMAGE.







Before you begin, please read Page 3 of "Assembly and Care Advice".

And remember, do not tighten until each step is completed or instructed.







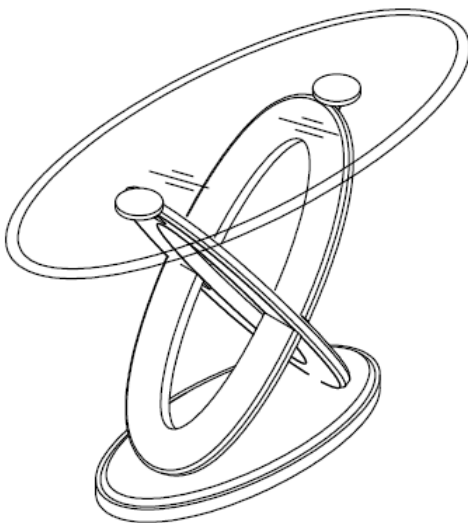

MD

Parts List

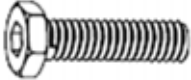
-  #1 x 1 pc
Glass Top
-  #2 x 1 pc
Stand A
-  #3 x 1 pc
Stand B
-  #4 x 1 pc
Base



Hardware List

-  #A x 6 pcs
Bolt 5/16"x1/2"
-  #B x 10 pcs
Bolt 5/16"x3/4"
-  #C x 4 pcs
Bolt 5/16"x1-1/4"
-  #D x 20 pcs
Lock Washer
-  #E x 20 pcs
Flat Washer
-  #F x 1 pc
Allen Wrench
-  #G x 2 pcs
Base Bracket
-  #H x 1 pc
Flat Bracket



Insert stand A (#2) through stand B (#3). Make sure the cutouts are aligned with each other.

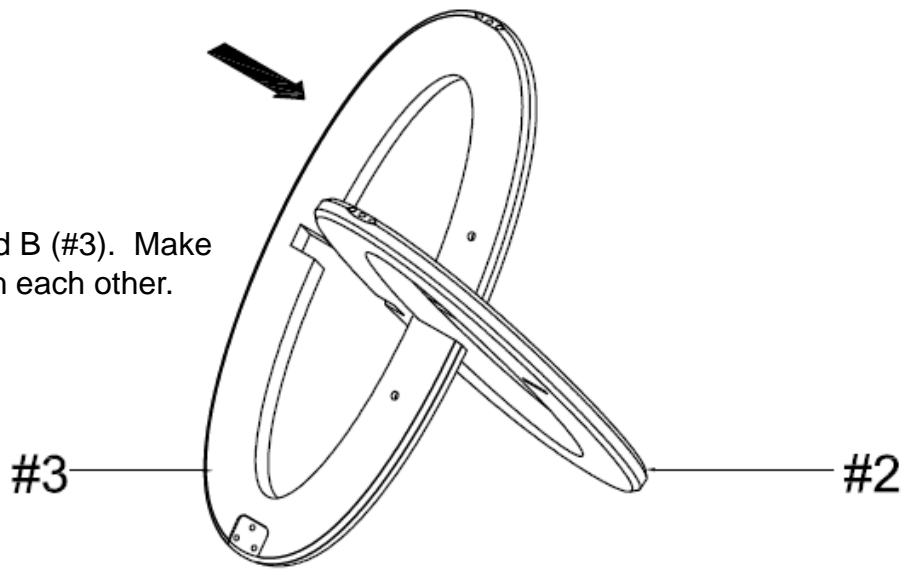

- I. Insert the flat bracket (#H) through the cutout on the stand A (#2) and align with the pre-drilled holes on the stand B (#3).
- II. Prepare 4 bolt assemblies by inserting FIRST the lock washer (#D) onto the bolt (#B) and then the flat washer (#E) onto the SAME bolt (#B), in that order.
- III. Insert the bolt assemblies through the holes on the flat bracket (#H) and secure those bolts using the Allen wrench (#F) to lock them with the stand B (#3).
- IV. Align the long sides of the two base brackets (#G) with the pre-drilled holes on the stand A (#2) and the stand B (#3).
- V. Prepare 6 bolt assemblies by inserting FIRST the lock washer (#D) onto the bolt (#B) and then the flat washer (#E) onto the SAME bolt (#B), in that order.
- VI. Insert the bolt assemblies through the holes on the base brackets (#G) and secure those bolts using the Allen wrench (#F) to lock them with the stand A (#2) and the stand B (#3).

Turn right (clockwise) to tighten

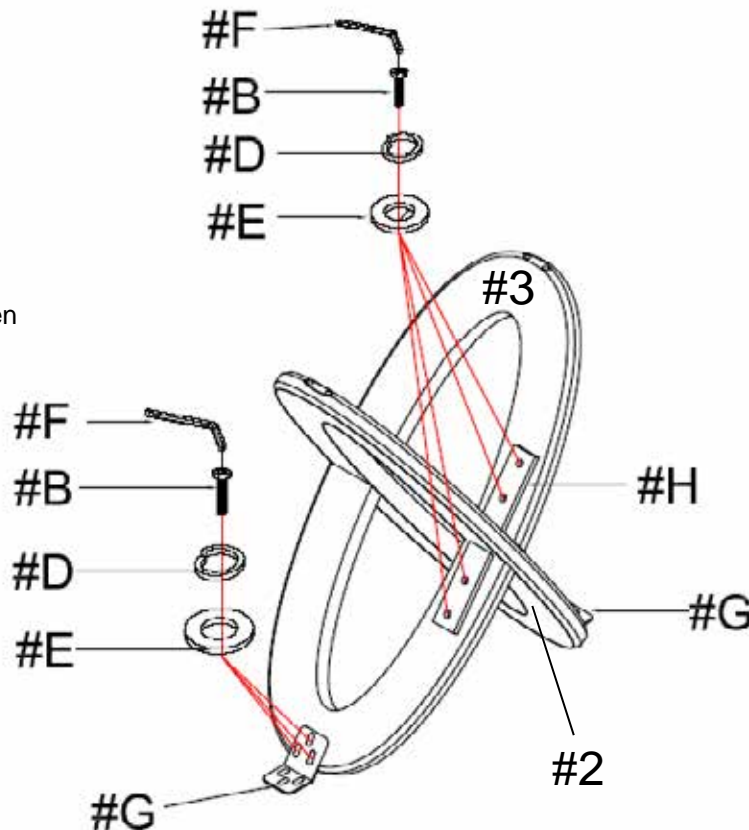

- | |
|-------------|
| #B x 10 pcs |
| #D x 10 pcs |
| #E x 10 pcs |
| #G x 2 pcs |
| #H x 1 pc |



#C x 4 pcs
#D x 4 pcs
#E x 4 pcs

- I. Align the base (#4) with the pre-drilled holes on the stand A (#2) and the stand B (#3).
- II. Prepare 4 bolt assemblies by inserting FIRST the lock washer (#D) onto the bolt (#C) and then the flat washer (#E) onto the SAME bolt (#C), in that order.
- III. Insert the bolt assemblies through the holes of the base (#4) and secure those bolts using the Allen wrench (#F) to lock them with the stand A (#2) and the stand B (#3).

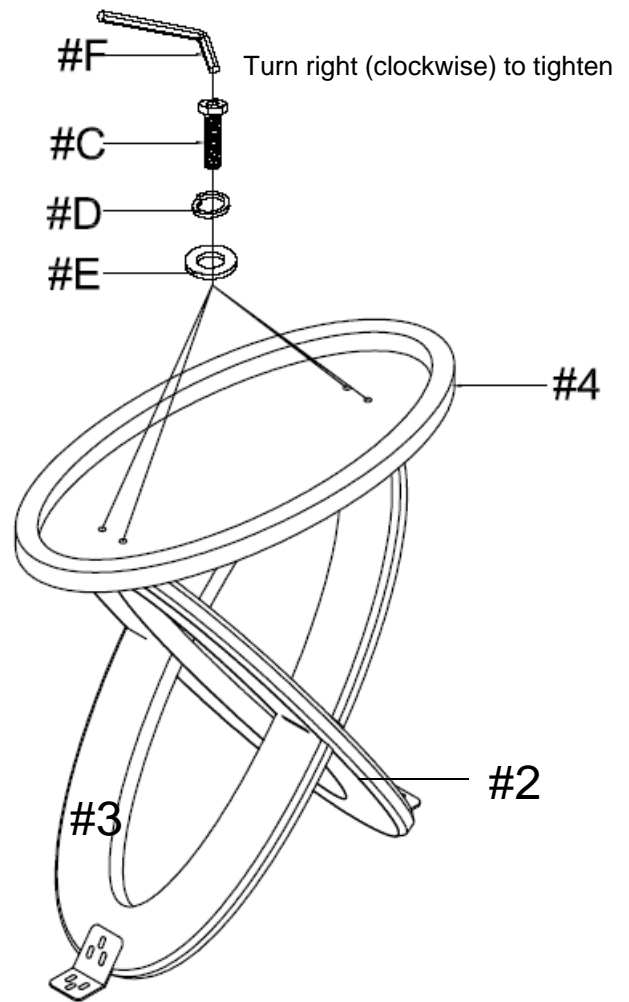

#A x 6 pcs
#D x 6 pcs
#E x 6 pcs

- I. Carefully place the glass top (#1) facing down on a protected surface.
- II. Align the short sides of the base brackets (#G) assembled on the stands with the pre-drilled holes on the glass top (#1).
- III. Prepare 6 bolt assemblies by inserting FIRST the lock washer (#D) onto the bolt (#A) and then the flat washer (#E) onto the SAME bolt (#A), in that order.
- IV. Insert the bolt assemblies through the holes of the base brackets (#G) and secure those bolts using the Allen wrench (#F) to lock them with the glass top (#1).
- V. Place the table in its upright position. Make sure the table is rested on a flat surface and does not feel loose or wobbly. If it does, double check that the bolts/screws are secured and properly tightened.

Turn right (clockwise) to tighten

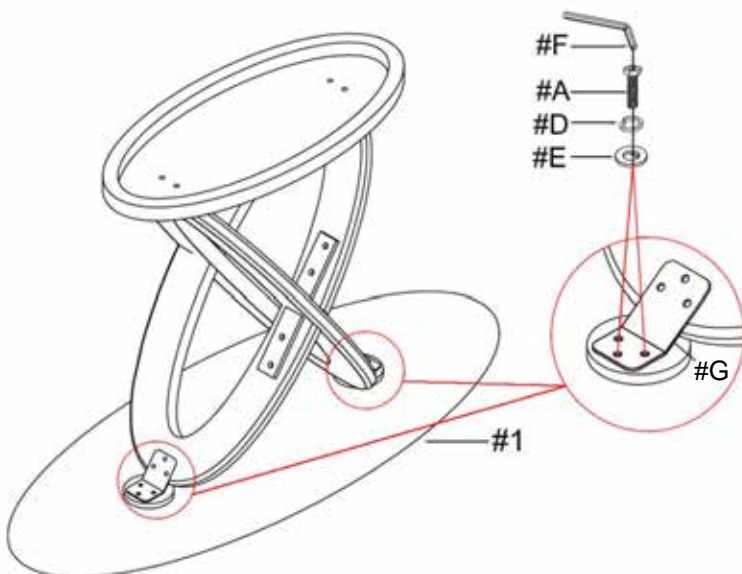

ASSEMBLY IS COMPLETED