

**Furniture of America**<sup>®</sup>

# Assembly Instructions

For more information contact our team: [service.ec@foagroup.com](mailto:service.ec@foagroup.com)

## CM1027-F

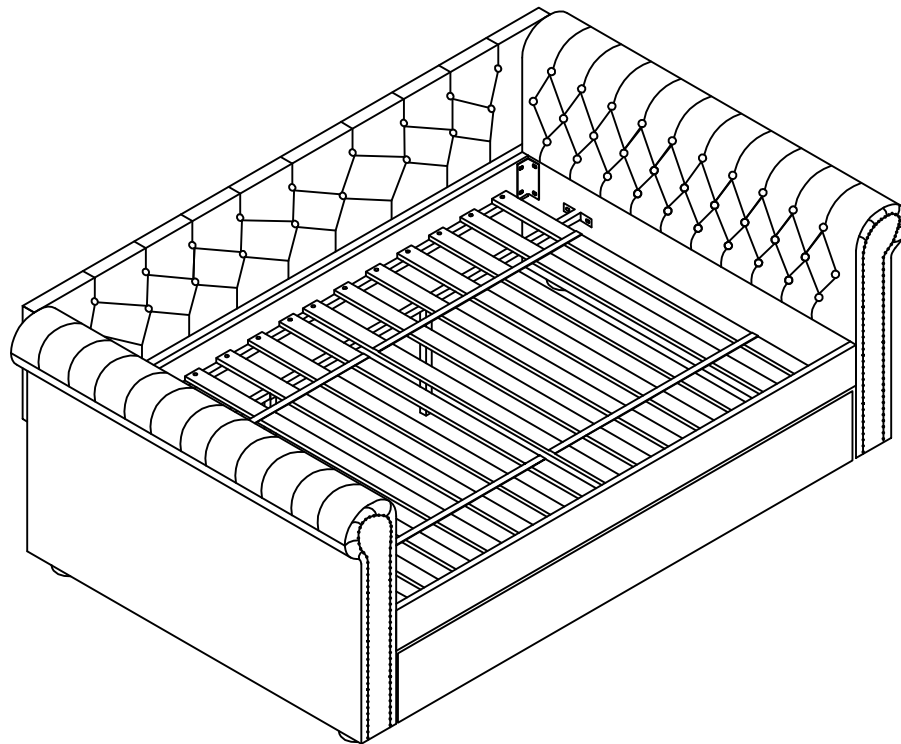

### ASSEMBLY RATING

The Assembly Rating is a 5-point system that shows the degree of effort needed in assembling a specific product (with 1 being easy and 5 being difficult). For some products, two persons are recommended.

EASY



DIFFICULT

### Tools Required For Assembly:

Allen Wrench

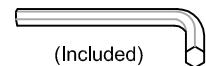

(Included)

Phillips Screwdriver



(Not Included)

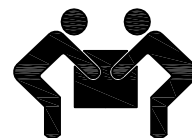

**2 PERSONS RECOMMENDED**

# ASSEMBLY & CARE ADVICE

FOR YOUR FURNITURE TO LAST, CORRECT ASSEMBLY AND PROPER MAINTENANCE ARE NECESSARY. PLEASE FOLLOW THE INFORMATION PROVIDED BELOW TO FULLY ENJOY YOUR FURNITURE.

## BASIC ASSEMBLY TECHNIQUES

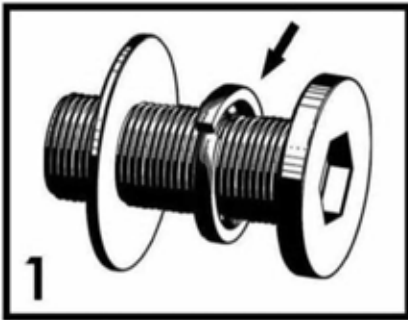

When lock or spring washer is used in an assembly, please make sure the lock or spring washer is placed between the larger flat washer and the head of the screw or bolt.

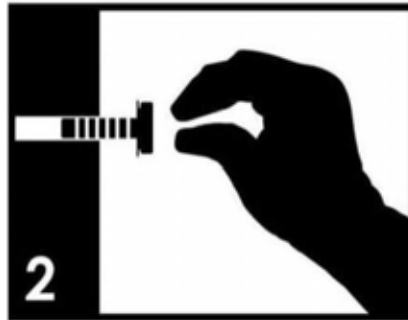

Position each part correctly and insert screws or bolts into their respective holes by hand tighten or using the proper hand tool. Only tighten when step is completed or when instructed to do so.

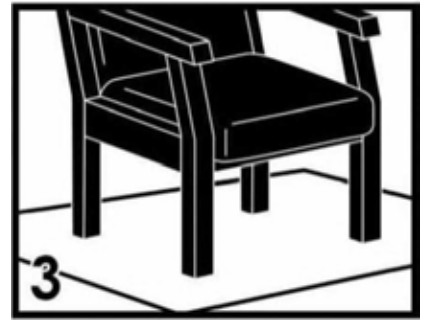

Use cardboard or carpet area when assembling furniture to prevent scratches. Make sure the furniture rests on a flat and level surface with each leg evenly touching the floor.

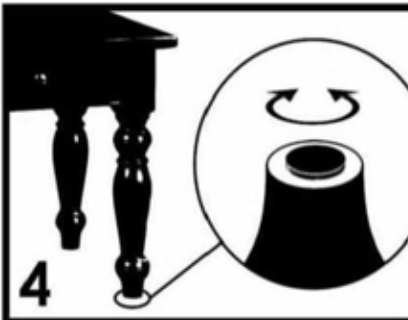

Some furniture comes with height adjustment knobs underneath each leg. To lower or to raise each leg, you need to turn clockwise or counterclockwise, respectively.

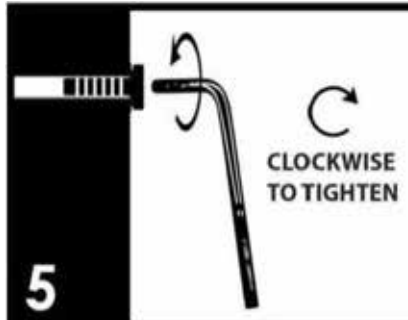

Make sure all parts are properly aligned, then use the appropriate hand tool to completely tighten the bolts or screws. Do not use power tools and do not overtighten.

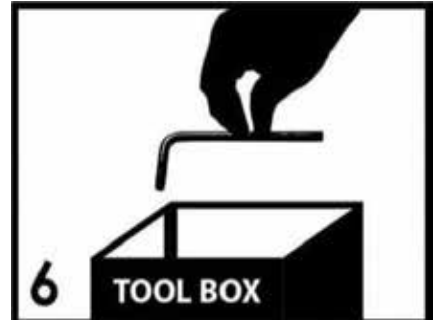

Save the instructions and store the Allen wrench or any supplied tool for later maintenance. After two weeks, check and tighten any loose hardware and repeat again every six months thereafter.

IT IS THE USER'S RESPONSIBILITY TO MAINTAIN THE FURNITURE. THE HARDWARE MAY LOOSEN OVER TIME AND MAY CAUSE THE FURNITURE TO BE WOBBLY AND UNABLE TO SUPPORT ITS INTENDED WEIGHT CAPACITY. THIS MAY LEAD TO COLLAPSE AND MAY CAUSE SERIOUS INJURY.

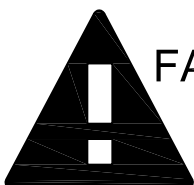

**FAILURE TO FOLLOW THE GUIDELINES ABOVE MAY RESULT IN INJURY AND/OR PROPERTY DAMAGE.**



Before you begin, please read Page 2 of "Assembly and Care Advice".

And remember, do not tighten until each step is completed or instructed.

### Parts List

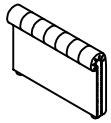

#1 x 1pc  
Left Arm

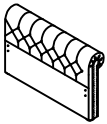

#2 x 1pc  
Right Arm

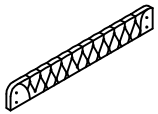

#3 x 1pc  
Back Rest

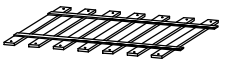

#4 x 2pcs  
Slats For Daybed



#5 x 1pc  
Back Rail

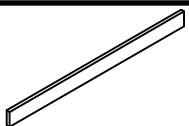

#6 x 1pc  
Front Rail

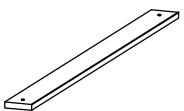

#7 x 1pc  
Middle Slat Panel



#8 x 1pc  
Support Rail

### Hardware List



#9 x 2pcs  
Support Leg  
25\*25\*395MM



Before you begin, please read Page 2 of "Assembly and Care Advice".

And remember, do not tighten until each step is completed or instructed.

## Hardware List



#A x 4pcs  
Bracket 90\*45\*3.0T mm



#B x 1pc  
Allen Wrench M5



#C x 1pc  
Allen Wrench M4



#D x 20pcs  
Lock washer Ø5/16"



#E x 20pcs  
Flat washer Ø5/16"



#Fx 6pcs  
Flat washer Ø1/4"

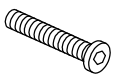

#G x 4pcs  
Bolt 5/16"\*2-1/2"



#H x 8pcs  
Bolt 5/16"\*1-1/2"

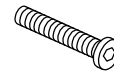

#I x 8pcs  
Bolt 5/16"\*1"



#J x 6pcs  
Bolt 1/4"\*1-3/4"

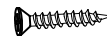

#K x 30pcs  
Screw 8\* 1-1/4"



Prepare 16 bolts assembly by inserting lock washer (#D), then flat washer (#E) onto bolts (#H,I). Align back/front rail (#5,6) to the end of the left/right arm (#1,2), then align bracket (#A) to the holes of the rails (#5,6) and arms (#1,2). Secure holes on the rails (#5,6) with bolts (#H) and secure holes on the arms (#1,2) with bolts (#I).

- #A x 4pcs
- #D x 16pcs
- #E x 16pcs
- #H x 8pcs
- #I x 8pcs

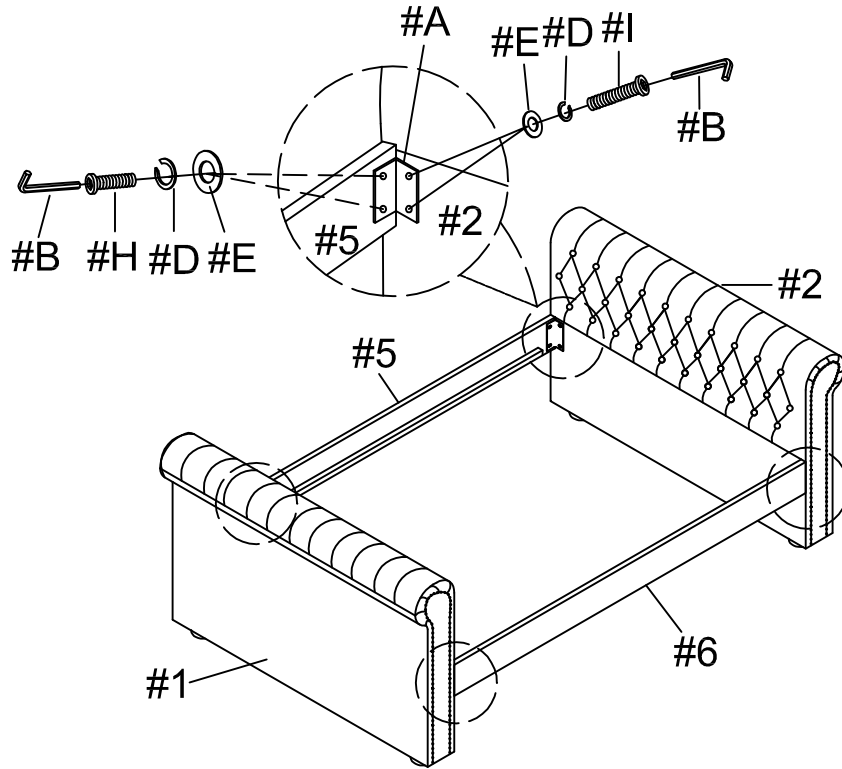

Prepare 4 bolts assembly by inserting washer (#F) onto bolts (#J). Align support rail (#8) to the holes of the arms (#1,2). Secure with bolts (#J).

- #F x 4pcs
- #J x 4pcs

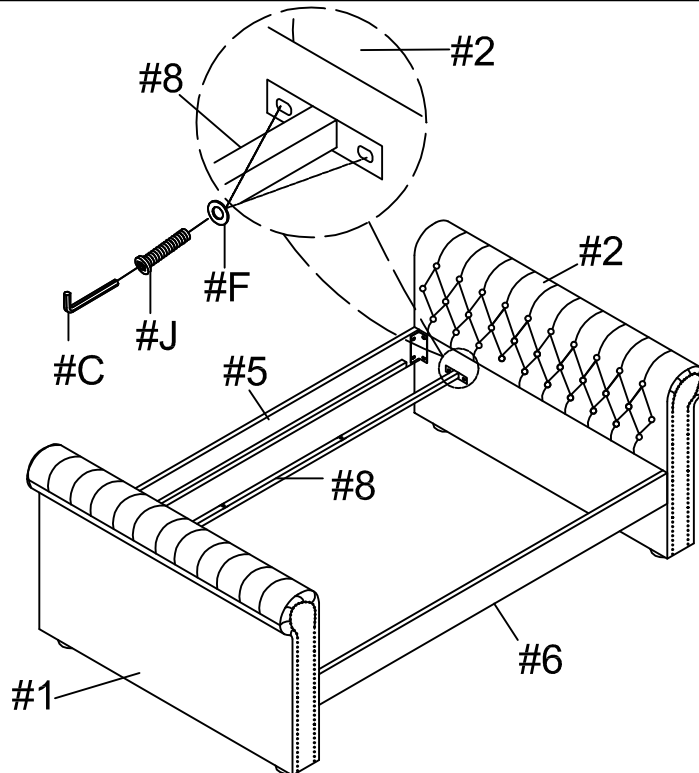



Prepare 2 bolts assembly by inserting washer (#F) onto bolts (#J). Align support legs (#9) to the holes of the support rail (#8). Secure with bolts (#J).

#F x 2pcs  
#J x 2pcs

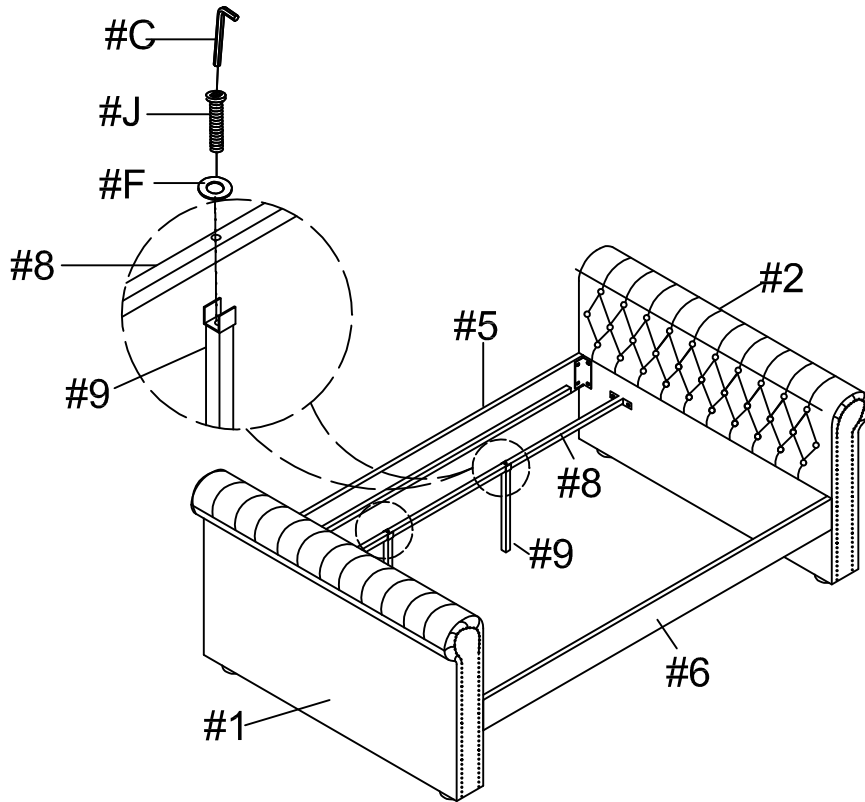

#D x 4pcs  
#E x 4pcs  
#G x 4pcs

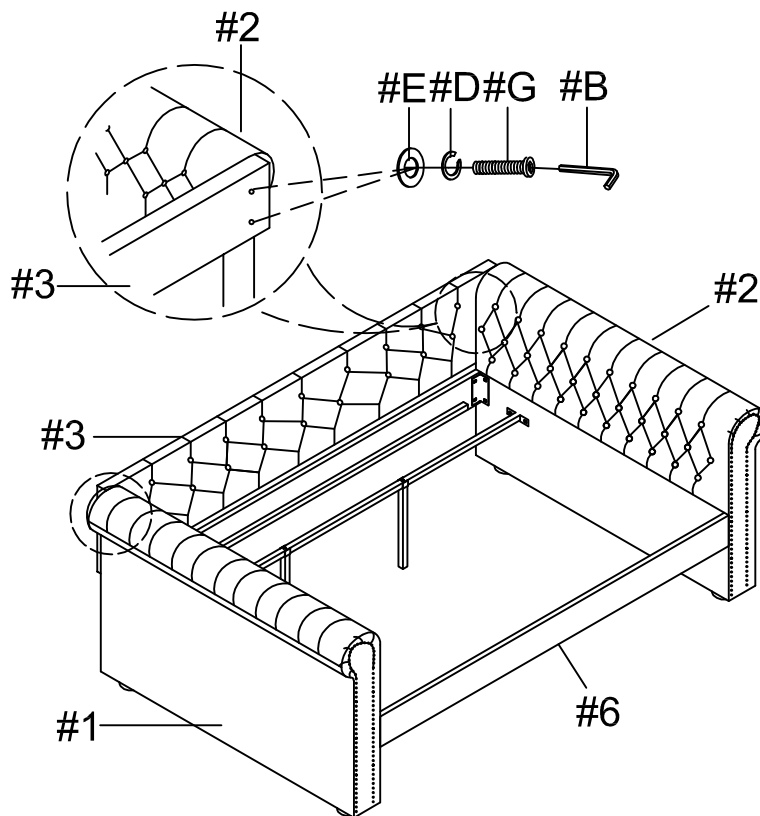

Prepare 4 bolts assembly by inserting lock washer (#D), then flat washer (#E) onto bolts (#G). Align back rest (#3) to the holes of the arms (#1,2). Secure with bolts (#G).



#5

#K x 30pcs

Align middle slat (#7) to the center of the daybed, then align slats (#4) next to the middle slat (#7). Secure with screws (#K).

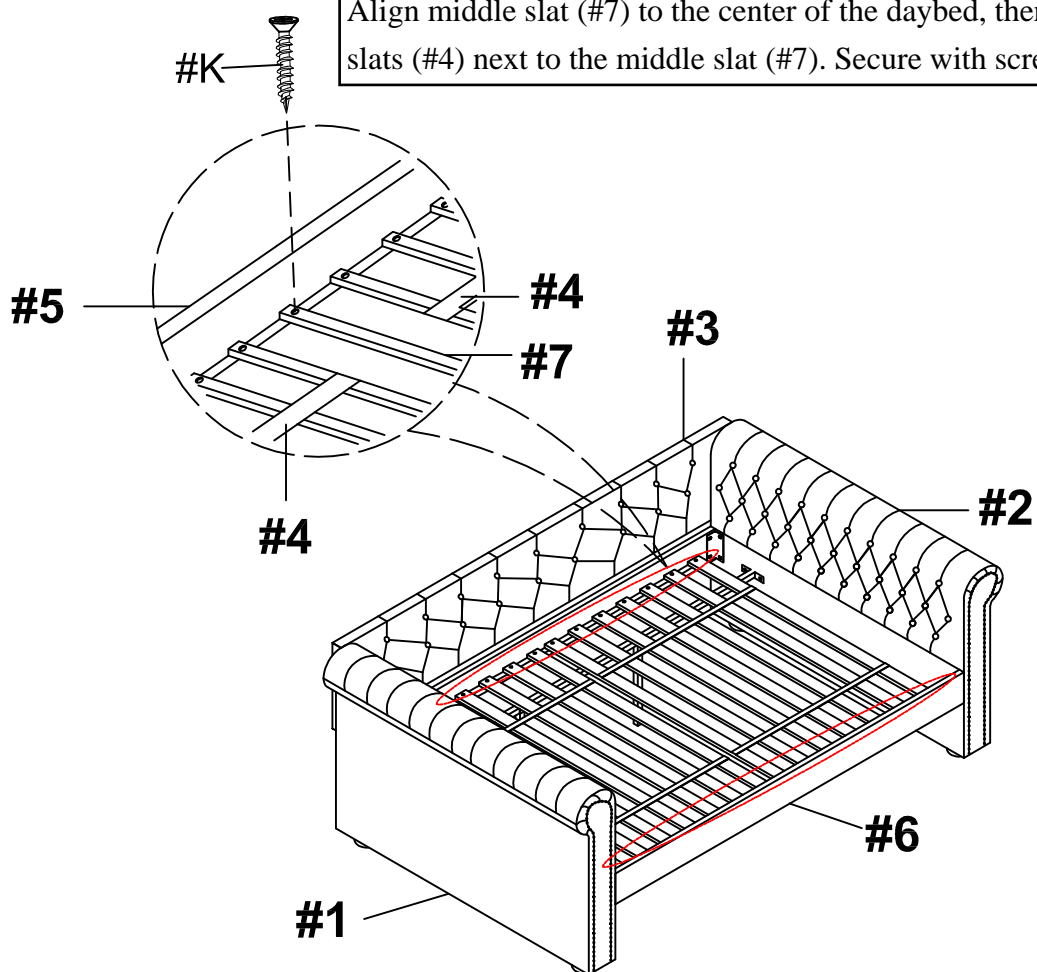

#6

Assembly Completed

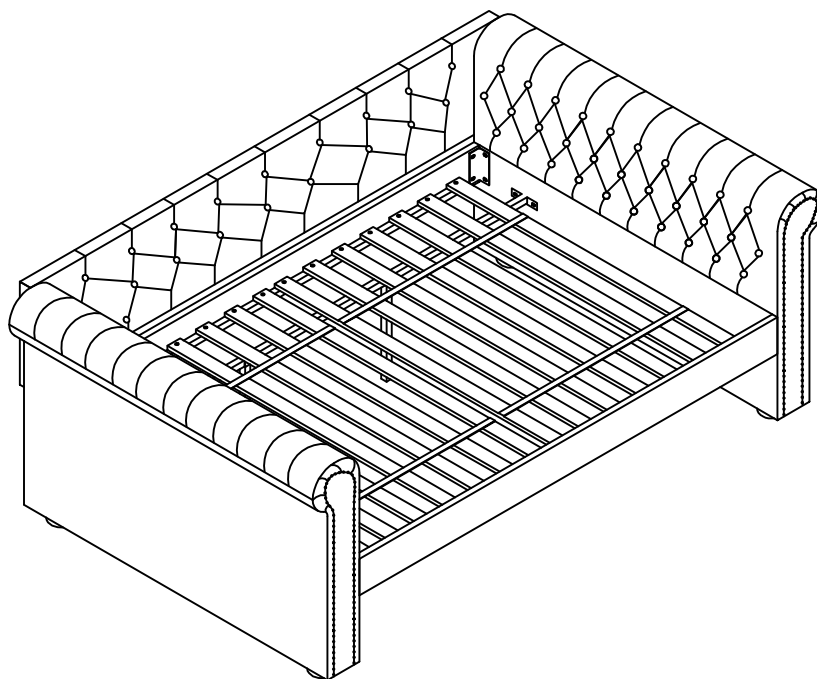

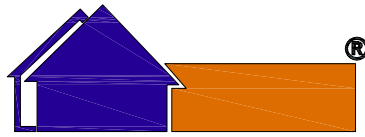

**Furniture of America**<sup>®</sup>

# Assembly Instructions

For more information contact our team: [service.ec@foagroup.com](mailto:service.ec@foagroup.com)

## CM1027-F-4

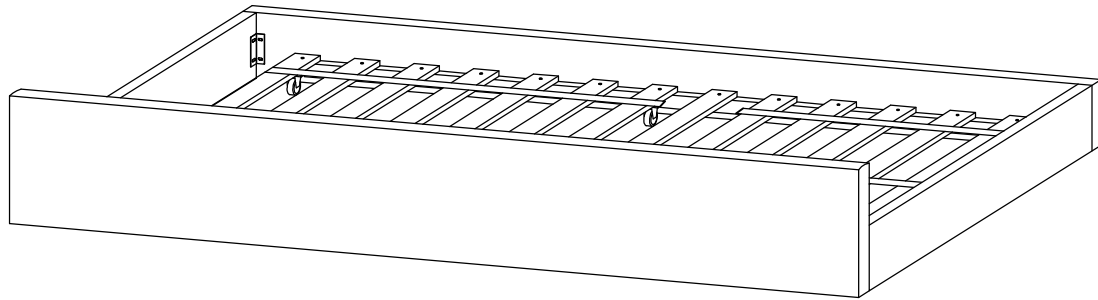

### ASSEMBLY RATING

The Assembly Rating is a 5-point system that shows the degree of effort needed in assembling a specific product (with 1 being easy and 5 being difficult). For some products, two persons are recommended.

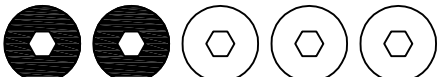
EASY  DIFFICULT

### Tools Required For Assembly:

Allen Wrench

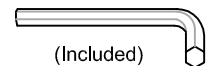

(Included)

Phillips Screwdriver



(Not Included)

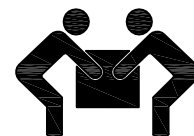

**2 PERSONS RECOMMENDED**



# ASSEMBLY & CARE ADVICE

FOR YOUR FURNITURE TO LAST, CORRECT ASSEMBLY AND PROPER MAINTENANCE ARE NECESSARY. PLEASE FOLLOW THE INFORMATION PROVIDED BELOW TO FULLY ENJOY YOUR FURNITURE.

## BASIC ASSEMBLY TECHNIQUES

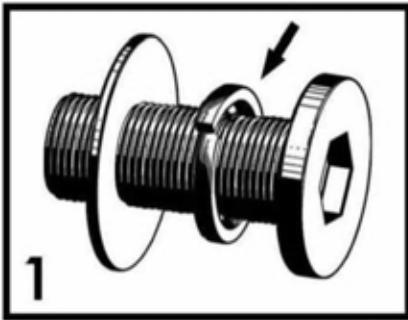

When lock or spring washer is used in an assembly, please make sure the lock or spring washer is placed between the larger flat washer and the head of the screw or bolt.



Position each part correctly and insert screws or bolts into their respective holes by hand tighten or using the proper hand tool. Only tighten when step is completed or when instructed to do so.

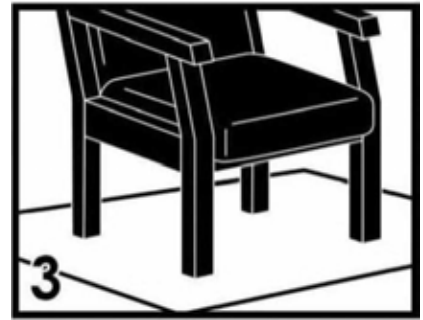

Use cardboard or carpet area when assembling furniture to prevent scratches. Make sure the furniture rests on a flat and level surface with each leg evenly touching the floor.

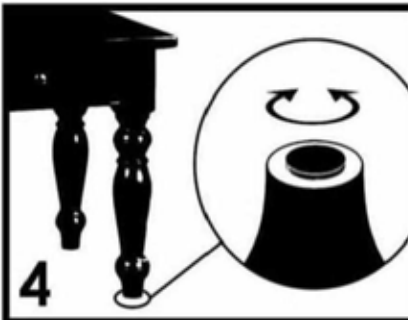

Some furniture comes with height adjustment knobs underneath each leg. To lower or to raise each leg, you need to turn clockwise or counterclockwise, respectively.

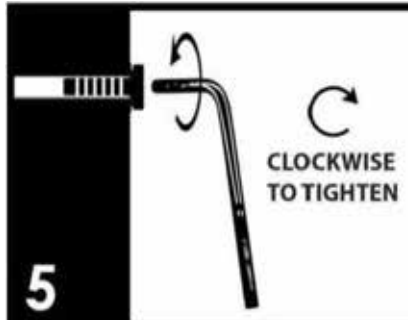

Make sure all parts are properly aligned, then use the appropriate hand tool to completely tighten the bolts or screws. Do not use power tools and do not overtighten.

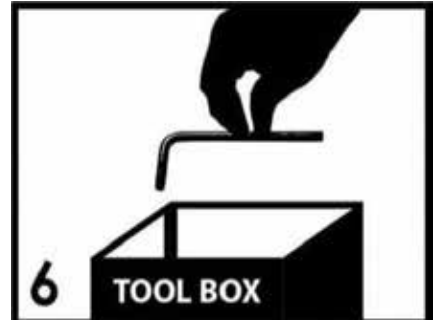

Save the instructions and store the Allen wrench or any supplied tool for later maintenance. After two weeks, check and tighten any loose hardware and repeat again every six months thereafter.

IT IS THE USER'S RESPONSIBILITY TO MAINTAIN THE FURNITURE. THE HARDWARE MAY LOOSEN OVER TIME AND MAY CAUSE THE FURNITURE TO BE WOBBLY AND UNABLE TO SUPPORT ITS INTENDED WEIGHT CAPACITY. THIS MAY LEAD TO COLLAPSE AND MAY CAUSE SERIOUS INJURY.

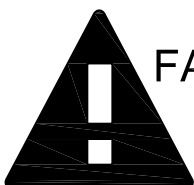

**FAILURE TO FOLLOW THE GUIDELINES ABOVE MAY RESULT IN INJURY AND/OR PROPERTY DAMAGE.**



Before you begin, please read Page 2 of "Assembly and Care Advice".

And remember, do not tighten until each step is completed or instructed.

### Parts List

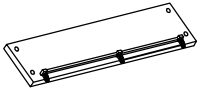

#1 x 1pc  
Trundle Front Panel

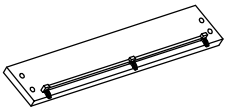

#2 x 1pc  
Trundle Back Panel

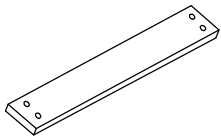

#3 x 2pcs  
Left & Right Panel

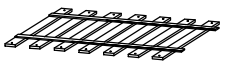

#4 x 2pcs  
Slats For Daybed

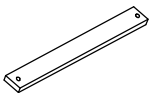

#5 x 1pc  
Middle Slat

### Hardware List

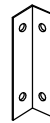

#A x 4pcs  
Bracket 130\*45\*3.0T mm



#B x 1pc  
Allen Wrench M5



#C x 16pcs  
Lock Washer 5/16"\*Ø12 mm



#D x 16pcs  
Flat Washer 5/16"\*Ø12 mm

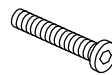

#E x 16pcs  
Bolt 5/16" x 3/4"

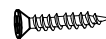

#F x 30pcs  
Screw M8\*1-1/4"



- #A x 4pcs
- #C x 4pcs
- #D x 4pcs
- #E x 4pcs

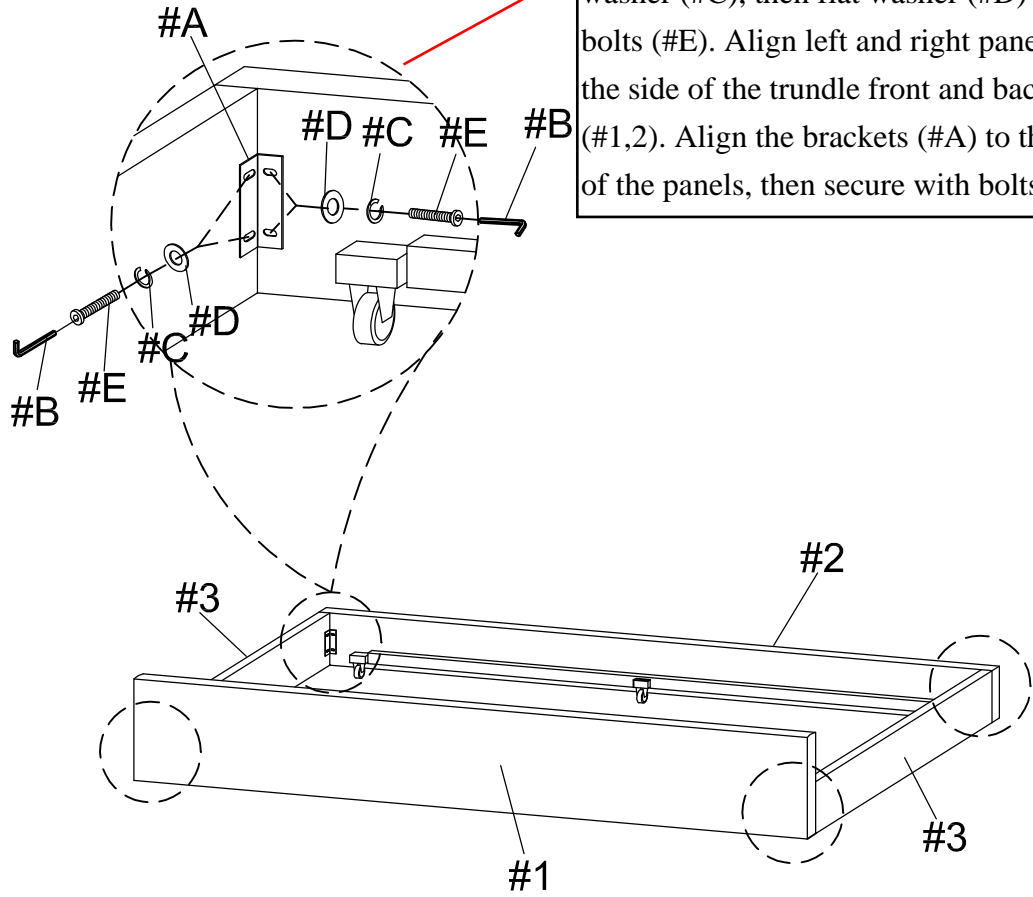

Prepare 16 bolts assembly by inserting lock washer (#C), then flat washer (#D) onto bolts (#E). Align left and right panels (#3) to the side of the trundle front and back panel (#1,2). Align the brackets (#A) to the holes of the panels, then secure with bolts (#E).



Align slats (#4,5) to the trundle. Make sure the middle slat (#5) is in the middle and in-between the side slats (#4).

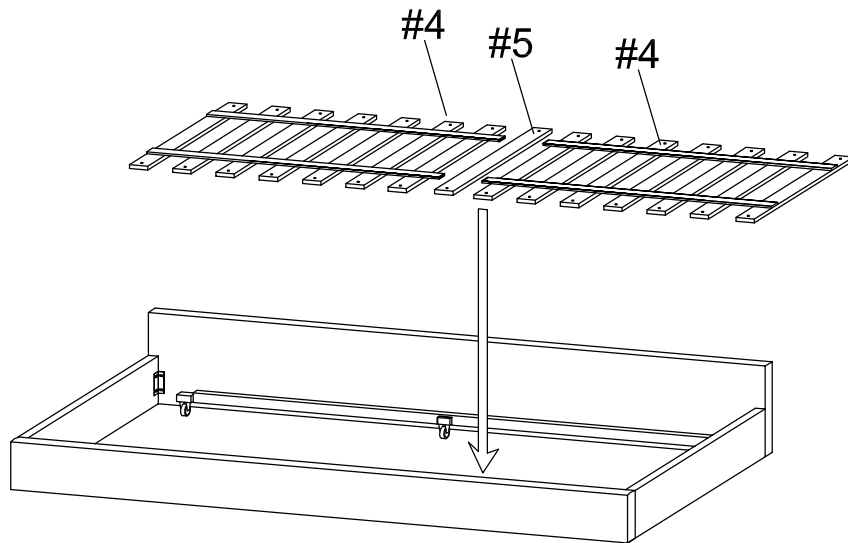



Secure slats to trundle with screw (#F).

#F x 30pcs

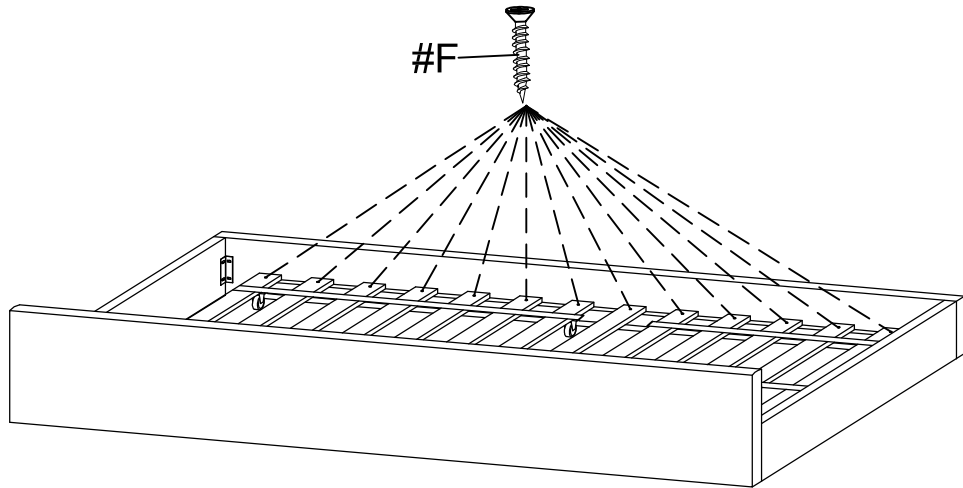

Assembly Completed

