



Furniture of America[®]

E-Commerce by Enitial Lab

ASSEMBLY INSTRUCTIONS

MODEL #

CM-GM339T

Questions?

GIVE US A CALL: 1-888-980-5122
MON – FRI 8:30AM – 5:30PM (PST)

TOOLS REQUIRED

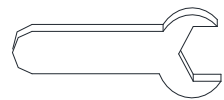

Wrench

(Included)

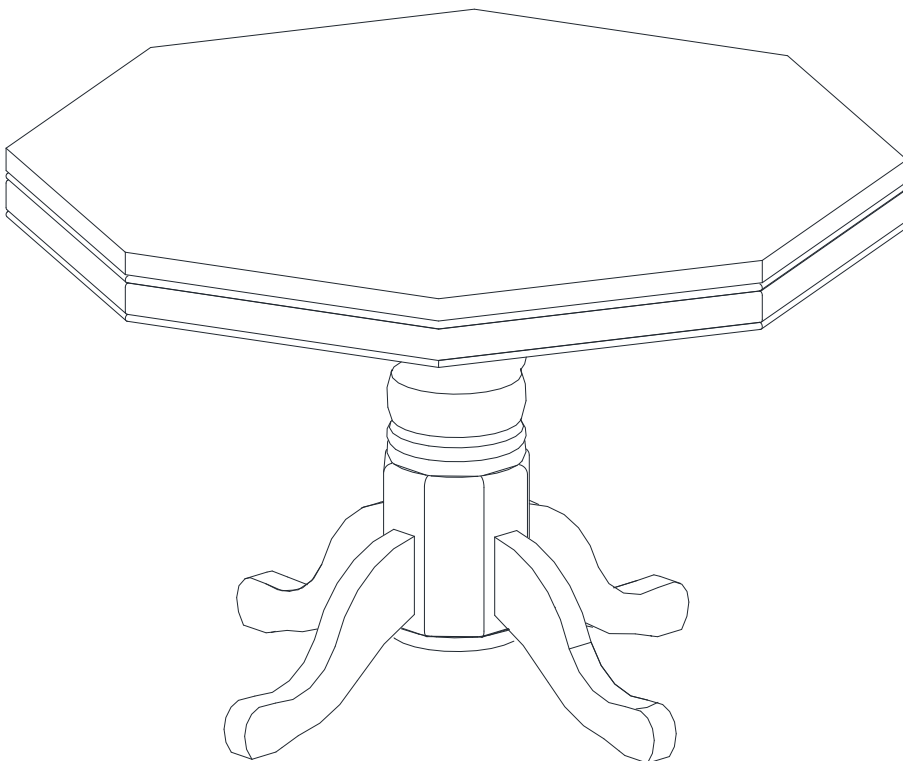

**2 - People
Recommended**

ASSEMBLY RATING



EASY —————> DIFFICULT

The Assembly Rating is a 5-point system showing the level of effort needed to assemble a specific product.



FOA Intro

Thank you for your purchase!

We hope you enjoy this new addition to your home for many years to come.

Our commitment to providing quality products does not simply end when you purchase our product. We fully stand behind our products from start to finish. Our customer service department is available Monday – Friday 8:30 AM – 5:30 PM Pacific and can help with assembly questions as well as, if necessary, replacing damaged or missing parts. To help expedite our service, please have these assembly instructions readily available, along with your order receipt.

 **Consumer Hotline**
Toll-Free 1-888-980-5122

 **WEBSITE**
www.foagroup.com

    foagroup

 **Monday to Friday**
8:30AM- 5:30PM (PST)

 **E-MAIL**
cs.ec@foagroup.com

 FurnitureOfAmerica

CHECK BEFORE STARTING

Are you missing anything?

Double-check all parts, hardware and accessories listed on Page 6 are accounted for.

Should we send any replacements?

Are there any irregularities or flaws in the parts? We can send replacements!

Check out our Quick Tips!

We recommend reviewing the pre-assembly handouts. Even experts need a refresher now and then!

Prep Time!

Please review the assembly instructions and all diagrams prior to assembling. Arrange parts as recommended on Page 7 and group identical hardware together to make assembling easier.

PRE ASSEMBLY INTRODUCTION

We understand building ready-to-assemble furniture can be a challenging experience for some. To help avoid confusion, we have provided some helpful tips that may speed up the process.

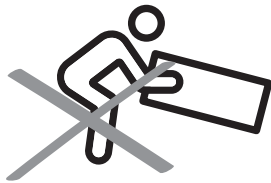

Teamwork

ALWAYS have at least two people to help with transporting and assembling the product to avoid potential injury and/or damage.

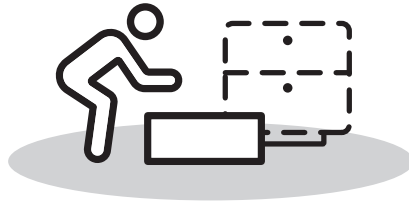
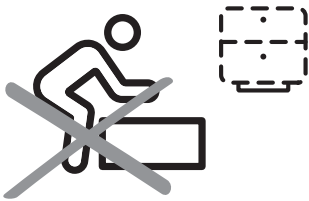

Suitable Location

Assembling near the area of the intended location is highly recommended.



Sufficient Space

Make sure you have enough space to move around during the assembly.

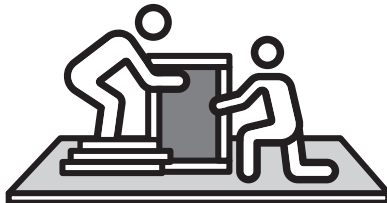

Avoid Scratches

Use cardboard, blankets or a carpeted area while assembling furniture to prevent scratches.

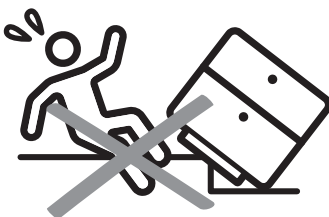

Flat Surface

Make sure the furniture rests on a flat and level surface with each leg evenly touching the floor.

ASSEMBLY AND CARE ADVICE



FAILURE TO FOLLOW THE GUIDELINES BELOW MAY RESULT IN INJURY AND/OR PROPERTY DAMAGE.



Position each part correctly and insert screws or bolts into their respective holes.

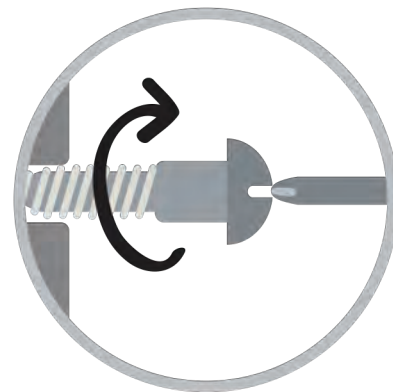

Turn clockwise to tighten and only tighten when step is completed or when instructed to do so.



Use the appropriate hand tools or power tools for assembly. Select steps, such as tightening screws and/or bolts, may require hand tools to avoid causing damage during assembly.

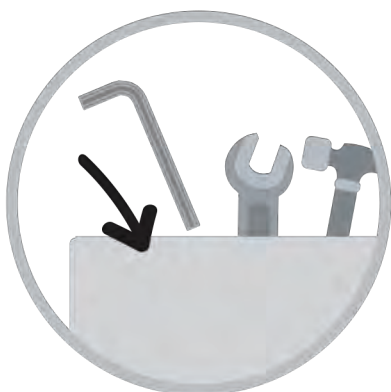

Save the instructions and store any supplied tools for later maintenance.

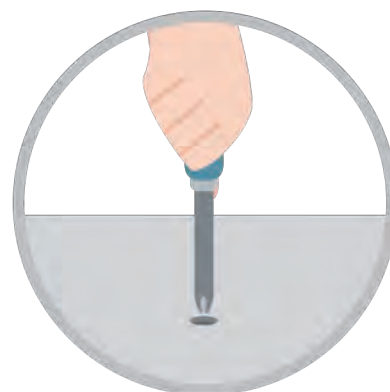

After two weeks, check and tighten any loose hardware and repeat again every six months thereafter.

IT IS THE USER'S RESPONSIBILITY TO MAINTAIN THE FURNITURE. THE HARDWARE MAY LOOSEN OVER TIME AND MAY CAUSE THE FURNITURE TO BE WOBBLY AND UNABLE TO SUPPORT ITS INTENDED WEIGHT CAPACITY. THIS MAY LEAD TO COLLAPSE AND MAY CAUSE SERIOUS INJURY.

GAME TABLE

CM-GM339T



- Please keep instructions for future reference.
- Check the quantity and irregularity of parts and hardware before you start.

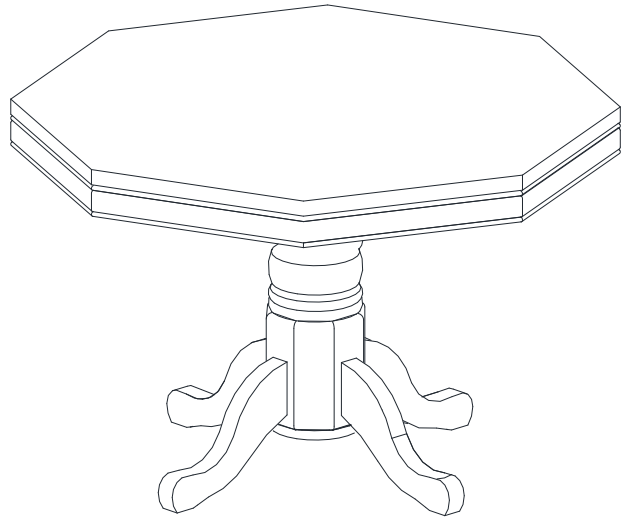

PARTS

#1 1pc

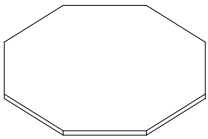
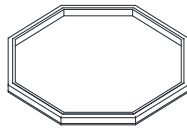

Table Top

#2 1pc



Apron

#3 1pc

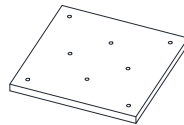

Wood Panel

#4 1pc

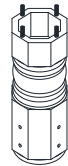

Base

#5 4pcs



Leg

HARDWARE

#A 4pcs



Bolt \varnothing 5/16" x 1-3/4"

#B 16pcs



Flat Washer \varnothing 5/16"

#C 12pcs

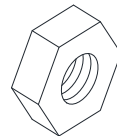

Hex Nut \varnothing 5/16"

#D 1pc

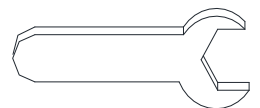

Wrench

#E 16pcs

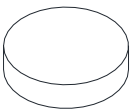







Sponge Mat

#F 4pcs

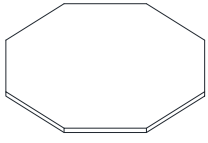

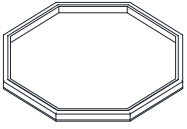
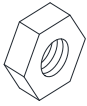
Lock Washer \varnothing 5/16"

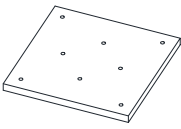
CM-GM339T is packed in 2 cases

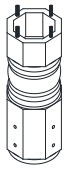
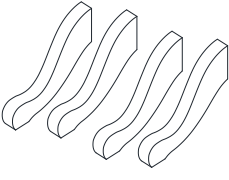
Carton	Designation	Part		Hardware
CM-GM339T-1	Table Top	#1		 #A x 4pcs  #B x 16pcs
	Apron	#2		 #C x 12pcs  #D x 1pc
	Wood Panel	#3		 #E x 16pcs  #F x 4pcs
CM-GM339T-2	Base	#4		
	Leg	#5		

ASSEMBLY INSTRUCTIONS

1

Part #4 x1pc

Part #5 x4pcs

Hardware #B x8pcs

Hardware #C x8pcs

1. Insert the threaded ends of the leg (#5) into the holes along the sides of the base (#4).

2. Apply a washer (#B) then a hex nut (#C) onto the threaded end from within. Then secure using the wrench (#D).

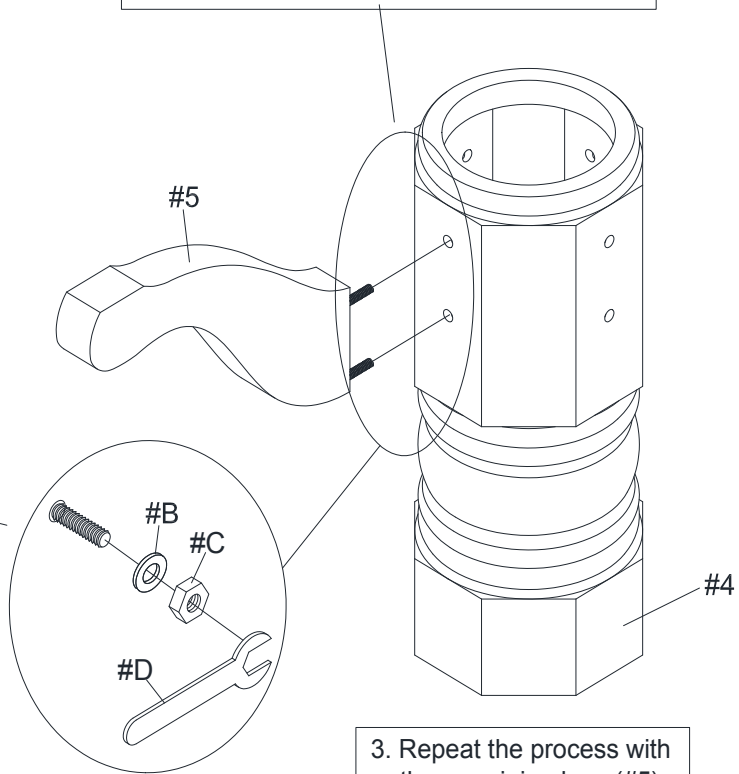

3. Repeat the process with the remaining legs (#5).

2

Part #3 x1pc

Hardware #B x4pcs

Hardware #C x4pcs

2. Place the wood panel (#3) onto the threaded ends along the top of the base (#4).

1. Turn the base (#4) upright.

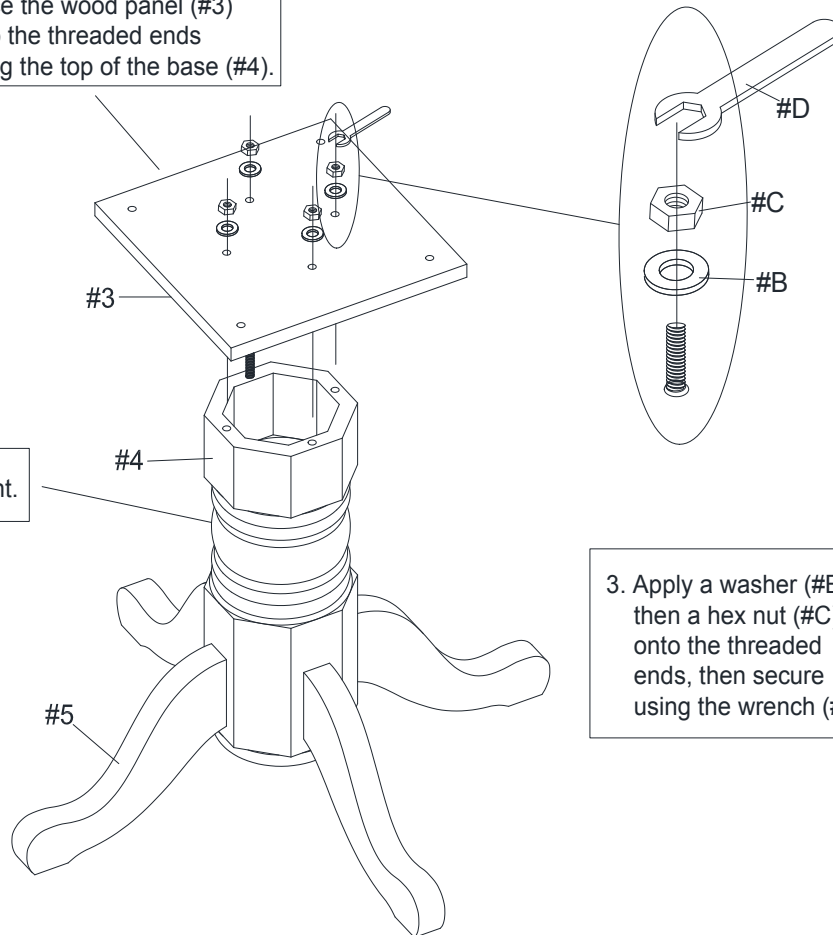

3. Apply a washer (#B) then a hex nut (#C) onto the threaded ends, then secure using the wrench (#D).

ASSEMBLY INSTRUCTIONS

3

3. Insert the bolt assemblies into the wood panel (#3) and secure using the wrench.

- Part #2 x1pc
- Hardware #A x4pcs
- Hardware #B x4pcs
- Hardware #F x4pcs

1. Place the apron (#2) face down onto a protected surface. Then align the wood panel (#3) to the holes located in the center.

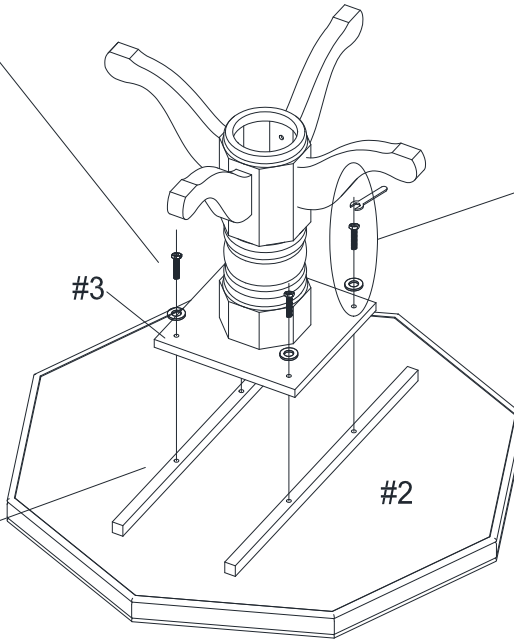

2. Prepare 4 bolt assemblies by first inserting a lock washer (#F) onto the bolt (#A) then a washer (#B) onto that same bolt (#A).

4

- Part #1 x1pc
- Hardware #E x16pcs

1. Turn the table upright.

2. Carefully place the table top (#1) onto the apron (#2).

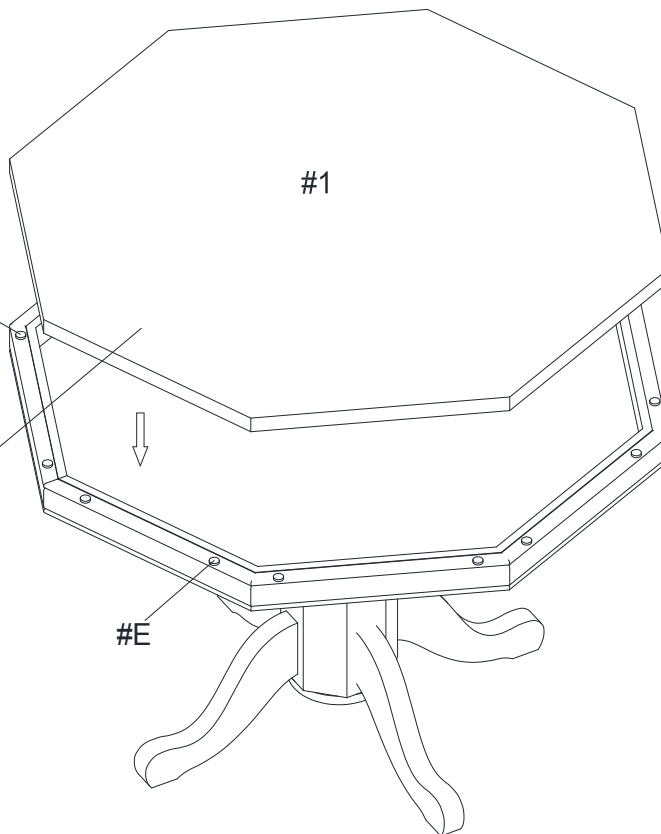

ASSEMBLY COMPLETED



Please ensure the furniture rests on an even and flat surface. If the product wobbles or feels loose, double-check all bolts and/or screws are properly tightened and secured.



Keep this handy!

Please retain this instruction manual and any order-related information for future reference.



Lift, don't drag!

To avoid damage to product please always LIFT the product when transporting or adjusting the placement.