

Furniture of America[®]

Assembly Instructions

CM-DK6707

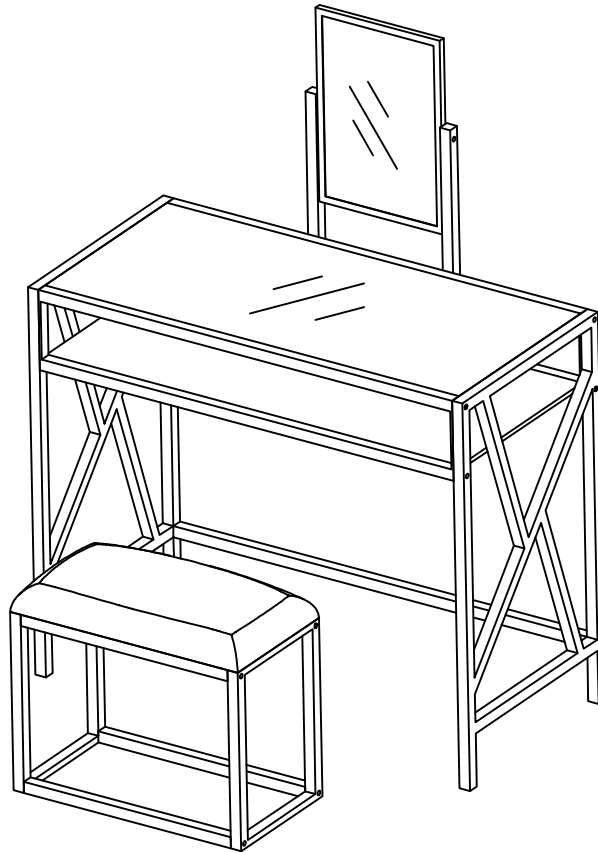

ASSEMBLY RATING

The Assembly Rating is a 5-point system that shows the degree of effort needed in assembling a specific product (with 1 being easy and 5 being difficult). For some products, two persons are recommended.

Tools Required For Assembly:

Allen Wrench

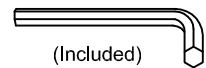

EASY



DIFFICULT

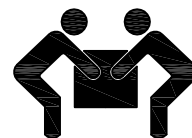

2 PERSONS RECOMMENDED

ASSEMBLY & CARE ADVICE

FOR YOUR FURNITURE TO LAST, CORRECT ASSEMBLY AND PROPER MAINTENANCE ARE NECESSARY. PLEASE FOLLOW THE INFORMATION PROVIDED BELOW TO FULLY ENJOY YOUR FURNITURE.

BASIC ASSEMBLY TECHNIQUES

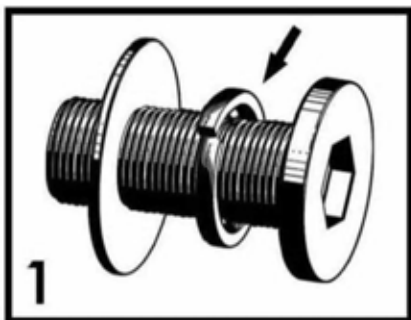

When lock or spring washer is used in an assembly, please make sure the lock or spring washer is placed between the larger flat washer and the head of the screw or bolt.



Position each part correctly and insert screws or bolts into their respective holes by hand tighten or using the proper hand tool. Only tighten when step is completed or when instructed to do so.

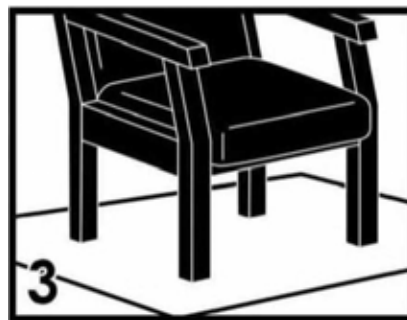

Use cardboard or carpet area when assembling furniture to prevent scratches. Make sure the furniture rests on a flat and level surface with each leg evenly touching the floor.

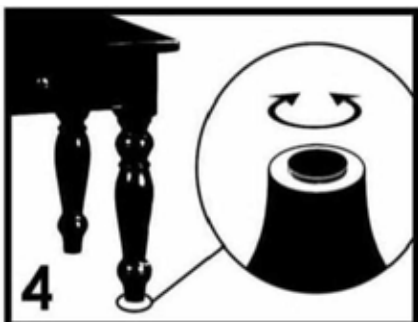

Some furniture comes with height adjustment knobs underneath each leg. To lower or to raise each leg, you need to turn clockwise or counterclockwise, respectively.

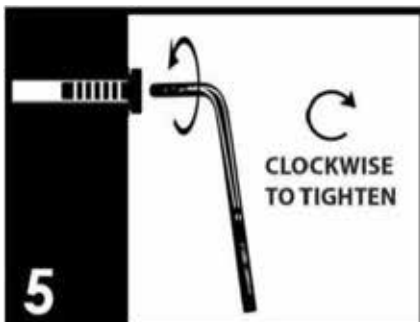

Make sure all parts are properly aligned, then use the appropriate hand tool to completely tighten the bolts or screws. Do not use power tools and do not overtighten.

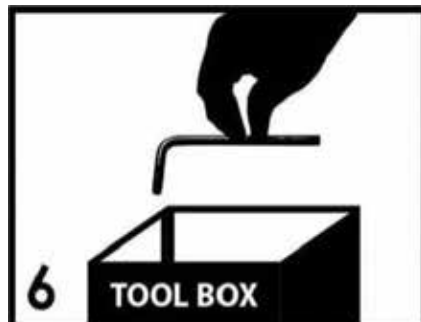

Save the instructions and store the Allen wrench or any supplied tool for later maintenance. After two weeks, check and tighten any loose hardware and repeat again every six months thereafter.

IT IS THE USER'S RESPONSIBILITY TO MAINTAIN THE FURNITURE. THE HARDWARE MAY LOOSEN OVER TIME AND MAY CAUSE THE FURNITURE TO BE WOBBLY AND UNABLE TO SUPPORT ITS INTENDED WEIGHT CAPACITY. THIS MAY LEAD TO COLLAPSE AND MAY CAUSE SERIOUS INJURY.

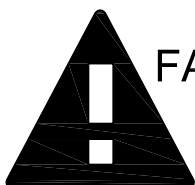

FAILURE TO FOLLOW THE GUIDELINES ABOVE MAY RESULT IN INJURY AND/OR PROPERTY DAMAGE.



Before you begin, please read Page 2 of "Assembly and Care Advice".

And remember, do not tighten until each step is completed or instructed.

Parts List

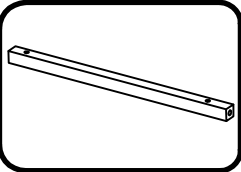

#1 x 2pcs
Stool Stretcher (2 HOLD)

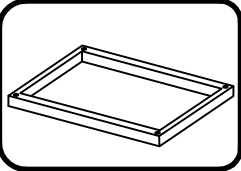

#2 x 2pcs
Stool Side Panel

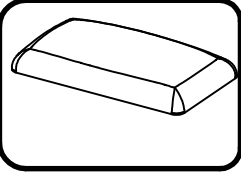

#3 x 1pc
Cushion

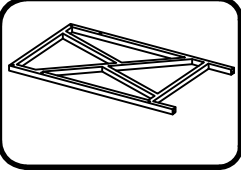

#4 x 2pcs
Side Panel

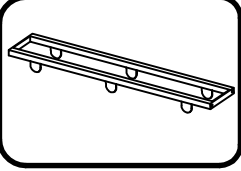

#5 x 1pc
Front Frame

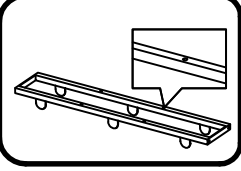

#6 x 1pc
Black Fraem

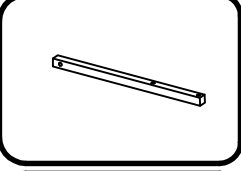

#7 x 2pcs
Mirror Stretcher

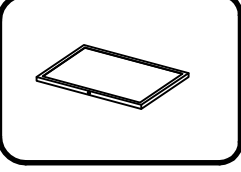

#8 x 1pc
Mirror

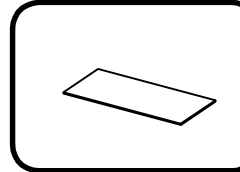

#9 x 2pcs
Glass

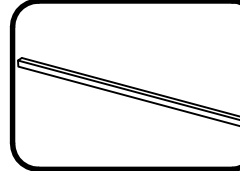

#10 x 1pc
Bottom Stretcher

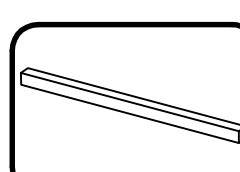

#11 x 2pcs
Stool Bottom Stretcher

Hardware List

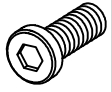

#A x 18pcs
Bolt 1/4" x1-1/2"



#Bx 8pcs
Foot Cap



#C x 18pcs
Bolt Cap



#D x 12pcs
Glass Pad

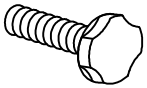

#Ex 2pcs
Bolt



#F x 2pcs
Nut

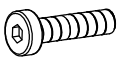

#G x 4pcs
Bolt 1/4" x2"



#H x 1pc
Allen Wrench



- 1) Align the stool stretchers (#1) to the holes of the stool side panels (#2). Make sure the stool stretchers (#1) with the holes are faced and placed upwards. Secure with bolts (#A).
- 2) Align bottom stretcher (#11) to the holes of the side panels (#2), then secure with bolts (#A).
- 3) Align cushion (#3) to the holes of the stool stretchers (#1). Secure with bolts (#G).
- 3) Fully tighten the bolts (#A,G), then attach bolt caps (#C) to each bolt holes. Attach foot caps (#B) to the bottom of the stool side panels (#2).

#A x 8pcs
 #C x 8pcs
 #B x 4pcs
 #G x 4pcs

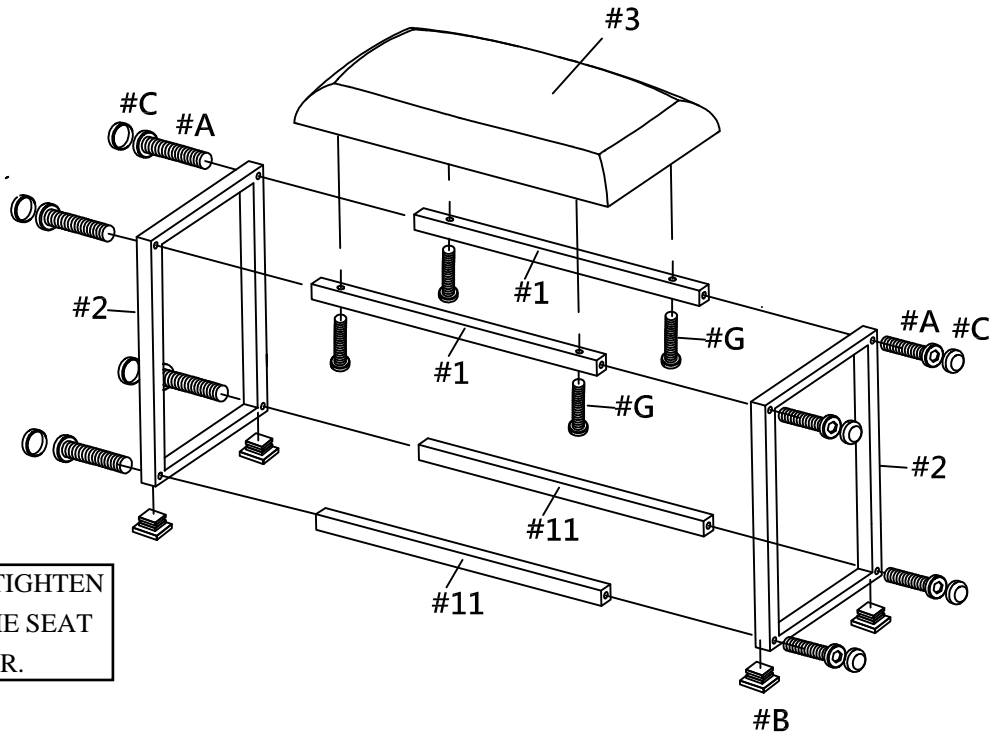

DO NOT FULLY TIGHTEN BOLTS UNTIL THE SEAT IS PUT TOGETHER.



DO NOT FULLY TIGHTEN BOLTS UNTIL THIS STEP IS PUT TOGETHER.

#A x 10pcs
 #C x 10pcs

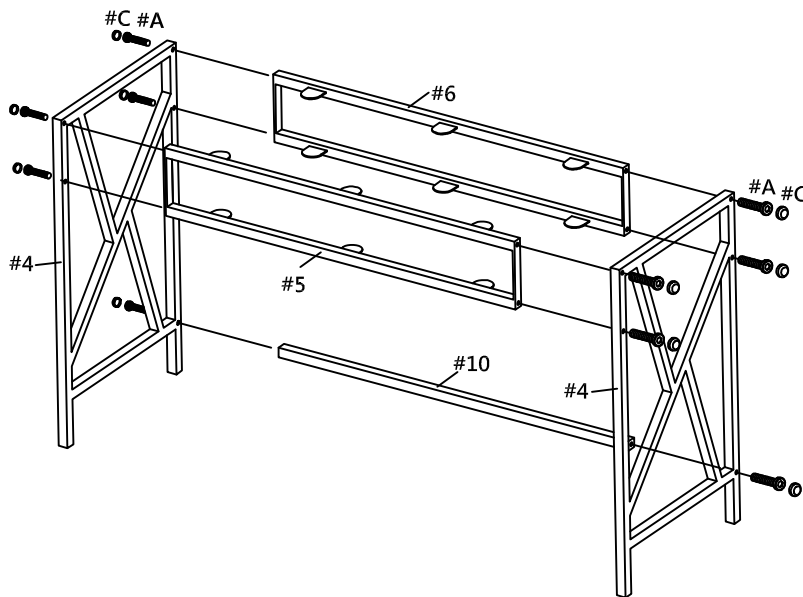

- 1) Align front frame (#5) to the front holes of the side panels (#4), then secure with bolts (#A).
- 2) Align back frame (#6) to the back top holes of the side panels (#4), then secure with bolts (#A).
- 3) Align bottom stretcher (#10) to the bottom back holes of the side panels (#4), then secure with bolts (#A).
- 4) Fully tighten bolts (#A), then attach bolt caps (#C) to each bolt holes.



DO NOT FULLY TIGHTEN UNTIL STEP IS DONE.

#A x 4pcs
#B x 4pcs
#E x 2pcs
#F x 2pcs

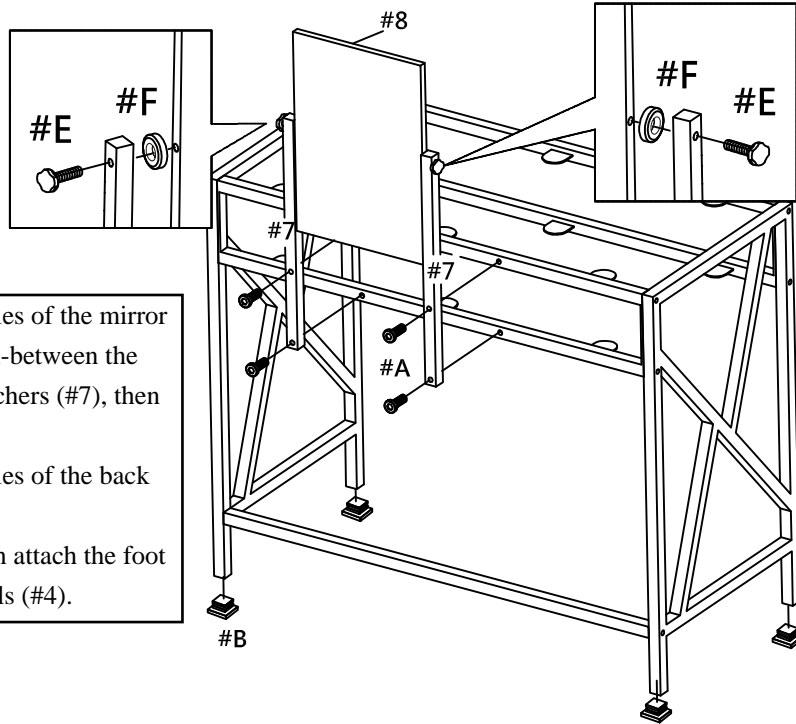

- 1) Align mirror stretchers (#7) to the holes of the mirror (#8). Make sure to place the nuts (#F) in-between the holes of the mirror (#8) and mirror stretchers (#7), then secure with bolts (#E).
- 2) Align mirror stretchers (#7) to the holes of the back frame (#6), then secure with bolts (#A).
- 3) Fully tighten all the bolts (#A,E), then attach the foot caps (#B) to the bottom of the side panels (#4).



#D x 12pcs

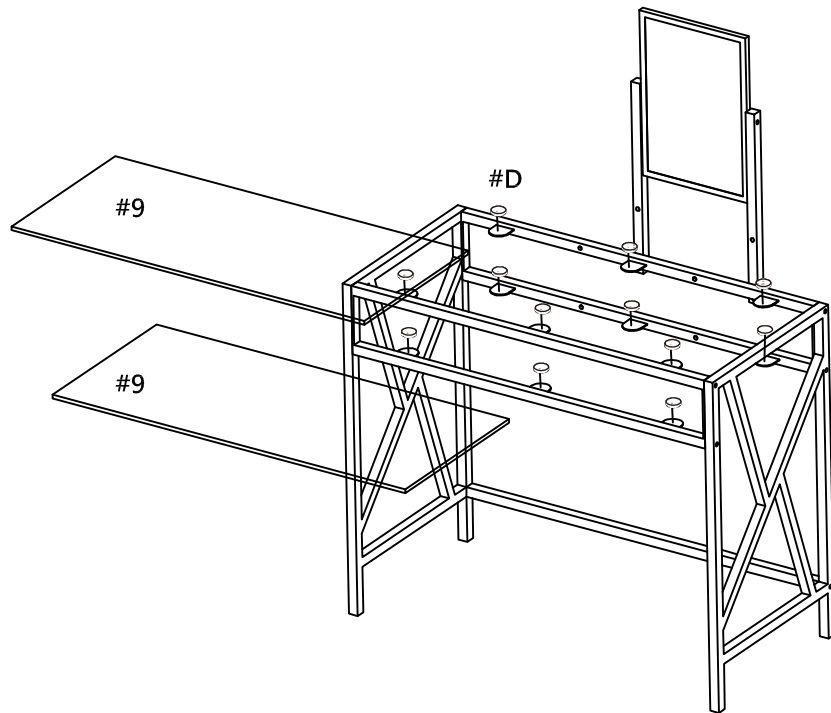

Attach the glass pads (#D) to the desk top and then carefully place the glass (#9) to the desk.