

Furniture of America®

# Assembly Instructions

CM-BT8333-BK/WH

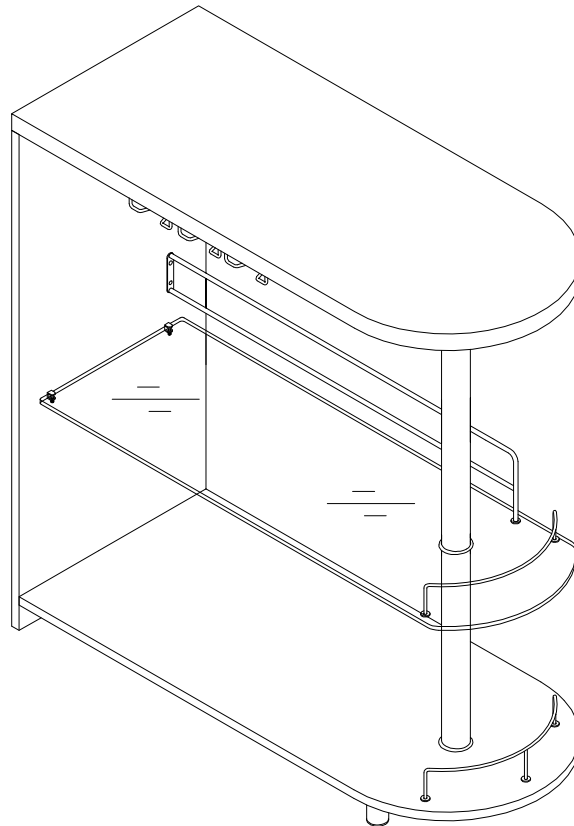

## ASSEMBLY RATING

The Assembly Rating is a 5-point system that shows the degree of effort needed in assembling a specific product (with 1 being easy and 5 being difficult). For some products, two persons are recommended.

EASY  DIFFICULT

## Tools Required For Assembly:

Allen Wrench

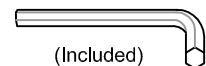

(Included)

Phillips Screwdriver



(Not Included)

Wrench

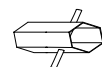

(Included)

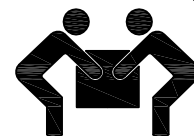

2 PERSONS RECOMMENDED

# ASSEMBLY & CARE ADVICE

FOR YOUR FURNITURE TO LAST, CORRECT ASSEMBLY AND PROPER MAINTENANCE ARE NECESSARY. PLEASE FOLLOW THE INFORMATION PROVIDED BELOW TO FULLY ENJOY YOUR FURNITURE.

## BASIC ASSEMBLY TECHNIQUES

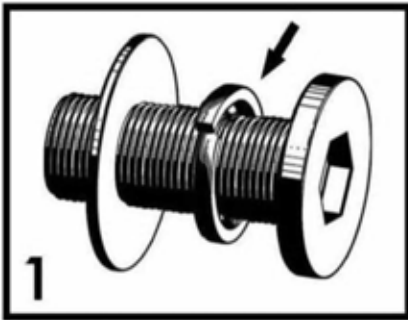

When lock or spring washer is used in an assembly, please make sure the lock or spring washer is placed between the larger flat washer and the head of the screw or bolt.



Position each part correctly and insert screws or bolts into their respective holes by hand tighten or using the proper hand tool. Only tighten when step is completed or when instructed to do so.

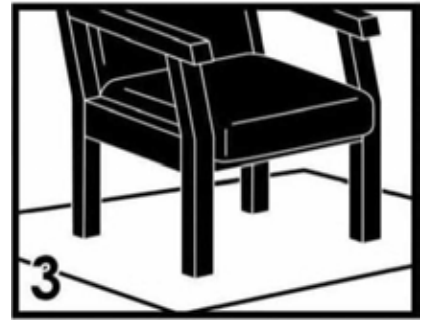

Use cardboard or carpet area when assembling furniture to prevent scratches. Make sure the furniture rests on a flat and level surface with each leg evenly touching the floor.

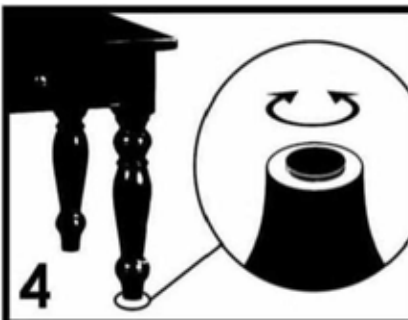

Some furniture comes with height adjustment knobs underneath each leg. To lower or to raise each leg, you need to turn clockwise or counterclockwise, respectively.

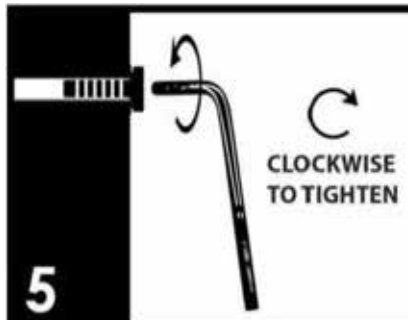

Make sure all parts are properly aligned, then use the appropriate hand tool to completely tighten the bolts or screws. Do not use power tools and do not overtighten.



Save the instructions and store the Allen wrench or any supplied tool for later maintenance. After two weeks, check and tighten any loose hardware and repeat again every six months thereafter.

IT IS THE USER'S RESPONSIBILITY TO MAINTAIN THE FURNITURE. THE HARDWARE MAY LOOSEN OVER TIME AND MAY CAUSE THE FURNITURE TO BE WOBBLY AND UNABLE TO SUPPORT ITS INTENDED WEIGHT CAPACITY. THIS MAY LEAD TO COLLAPSE AND MAY CAUSE SERIOUS INJURY.

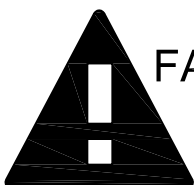

**FAILURE TO FOLLOW THE GUIDELINES ABOVE MAY RESULT IN INJURY AND/OR PROPERTY DAMAGE.**



Before you begin, please read Page 2 of "Assembly and Care Advice".

And remember, do not tighten until each step is completed or instructed.

### Parts List

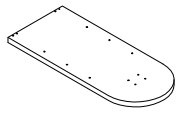

#1 x 1pc  
Top Panel



#2 x 1pc  
Side Panel

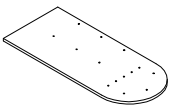

#3 x 1pc  
Bottom Panel

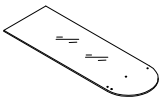

#4 x 1pc  
Glass Shelf

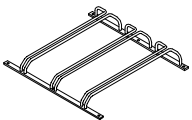

#5 x 1pc  
Top Panel Frame

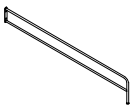

#6 x 1pc  
Guardrail



#7 x 1pc  
Glass Shelf Guardrail



#8 x 1pc  
Bottom Panel Guardrail



#9 x 2pcs  
Support Tube



#10 x 2pcs  
Leg



#11 x 1pc  
Bracket

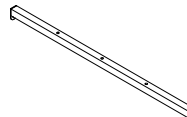

#12 x 1pc  
Bottom Support Tube A

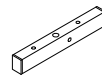

#13 x 1pc  
Bottom Support Tube B



Before you begin, please read Page 2 of "Assembly and Care Advice".

And remember, do not tighten until each step is completed or instructed.

### Hardware List



#A x 2pcs  
Bolt M5 X 12



#B x 16pcs  
Bolt 1/4" X 5/8"

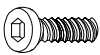

#C x 3pcs  
Bolt 1/4" X 3/8"



#D x 7pcs  
Bolt 1/4" X 1-9/16"



#E x 1pc  
Hex Nut



#F x 1pc  
Flat Washer Ø20



#G x 8pcs  
Flat Washer Ø14



#H x 1pc  
Allen Wrench M4



#I x 1pc  
Wrench M8

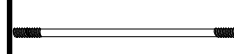

#J x 1pc  
Stud Bolt 5/16" X 39-1/8"



#K x 4pcs  
Cam Bolt



#L x 4pcs  
Cam Lock



#M x 4pcs  
Wood Dowel Ø8 X 30



#N x 3pcs  
Cap Ø59 X 4



#O x 2pcs  
Shelf Support



#P x 2pcs  
Stud Bolt 1/4" X 1-3/8"



Place the top panel (#1) onto a protected surface.

- #B x 10pcs
- #J x 1pc
- #K x 2pcs
- #M x 2pcs

1. Insert 2 cam bolts (#K) into the two outer pre-drilled holes along the end. Secure using a Phillips screwdriver. Insert 2 wood dowels (#M) into the two inner pre-drilled holes along the end.

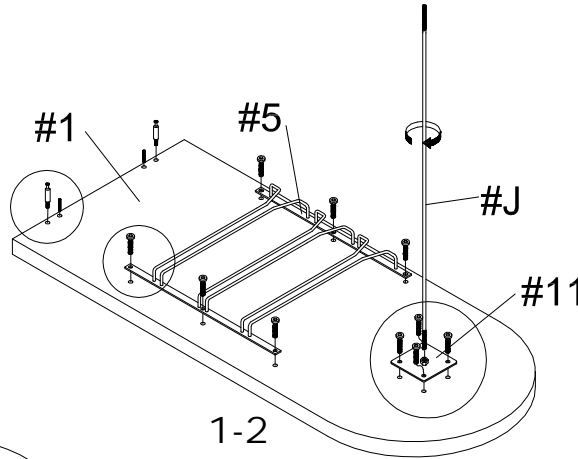
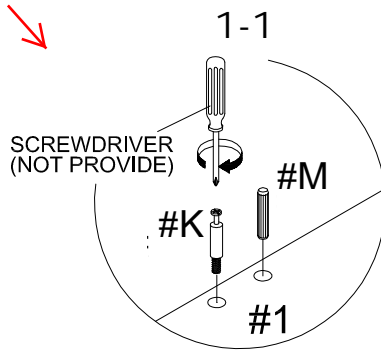

3. Align the bracket (#11) to the four pre-drilled holes near the curved end of the top panel (#1). Insert stud bolt (#J) into center hole, turn right to tighten. Insert 4 bolts (#B) to the corner holes and secure using the Allen wrench (#H).

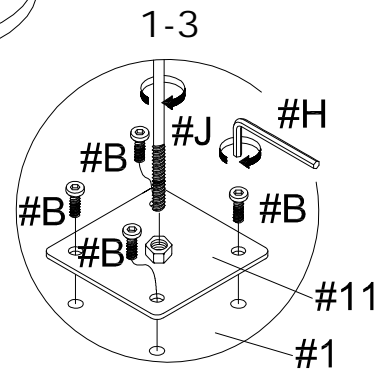
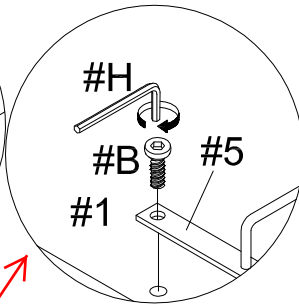

2. Align the top panel frame (#5) to the pre-drilled holes along the center of the top panel (#1). Insert a total of 6 bolts (#B) along the sides and secure using the Allen wrench (#H).



1. Insert 2 cam bolts (#K) into the two outer pre-drilled holes along the end of the side panel (#2). Secure using a Phillips screwdriver. Insert 2 wood dowels (#M) into the two inner pre-drilled holes along the end.

- #K x 2pcs
- #L x 2pcs
- #M x 2pcs
- #N x 1pc

2. Insert two cam locks (#L) into the large pre-drilled holes along the side of the side panel (#2). Once inserted, insert the bottom pre-drilled holes onto the ends of the cam bolts (#K) and wood dowels (#M). Lock cam lock (#L) using a Phillips screwdriver.

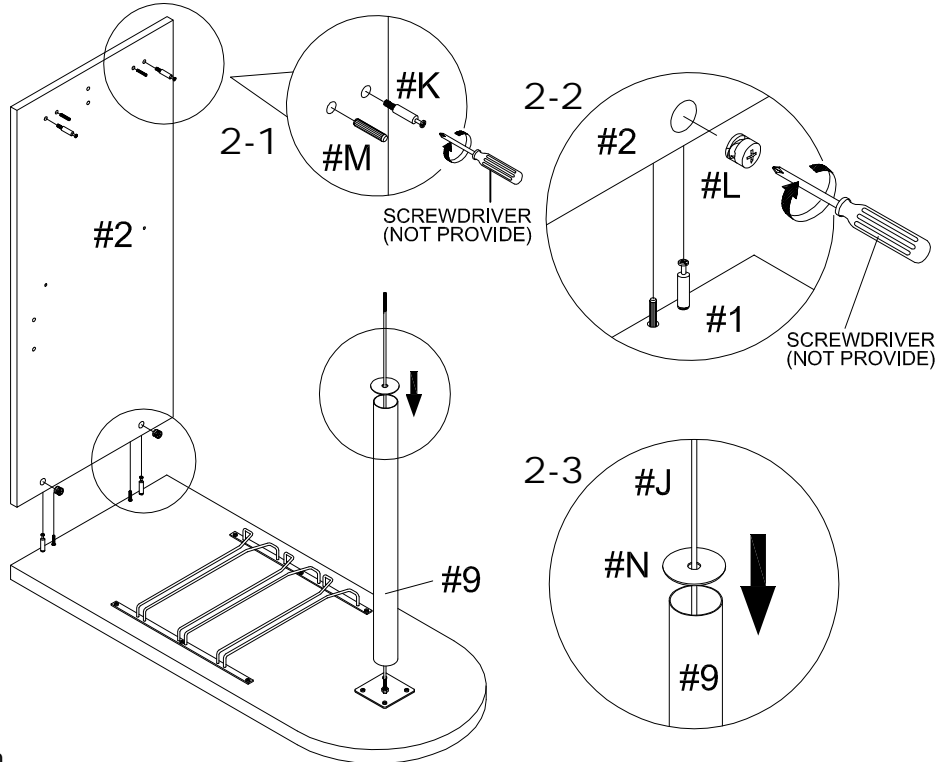

3. Apply the support tube (#9) onto the stud bolt (#J), then the cap (N).



#A x 2pcs  
#N x 2pcs  
#O x 2pcs

1. Align the 2 shelf supports (#O) to the pre-drilled holes along the center of the side panel (#2). Insert 2 bolts (#A) and secure using a Phillips screwdriver.

2. Apply glass shelf (#4) into the shelf supports (#O) and onto stud bolt (#J).

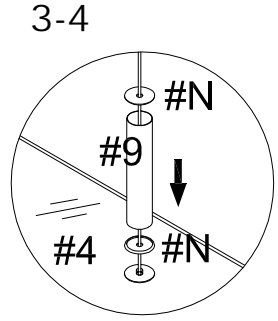
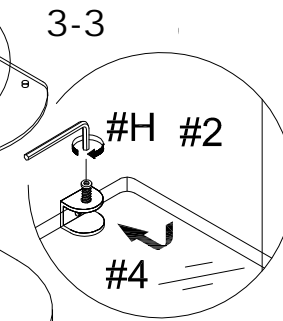
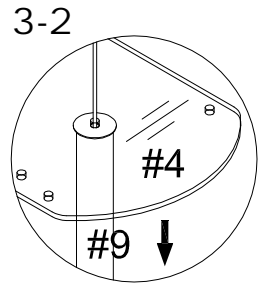
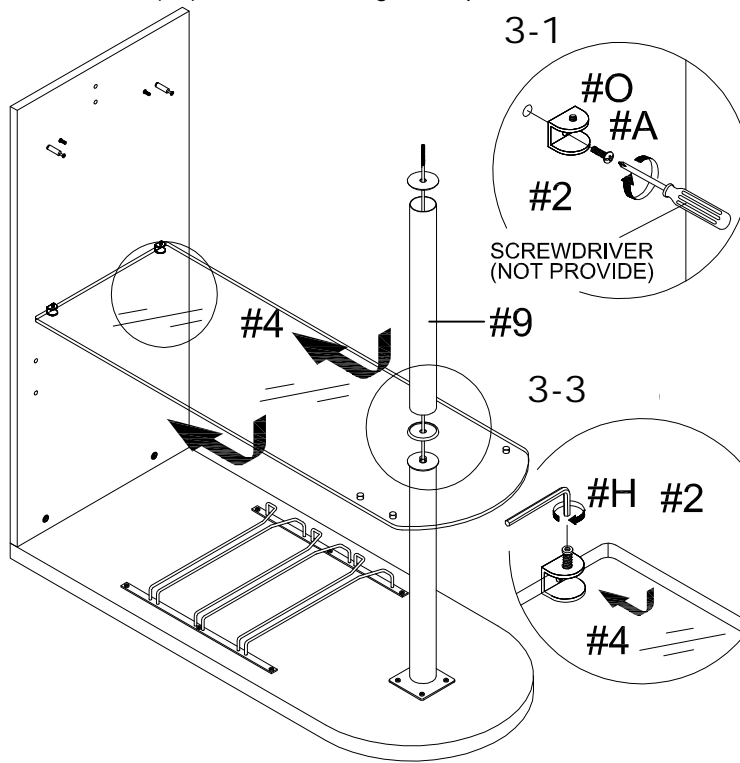

4. Apply cap (#N), support tube (#9), then another cap (#N), in that order onto the stud bolt (#J).



#L x 2pcs

1. Apply the bottom panel (#3) onto the stud bolt (#J).

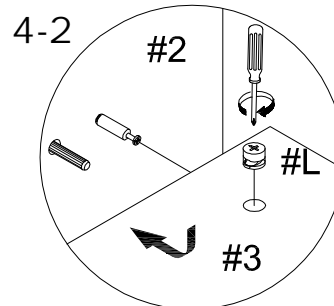
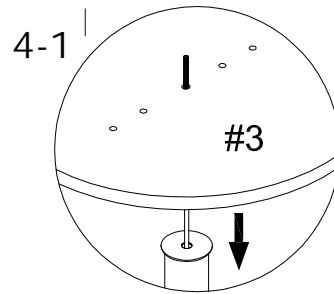
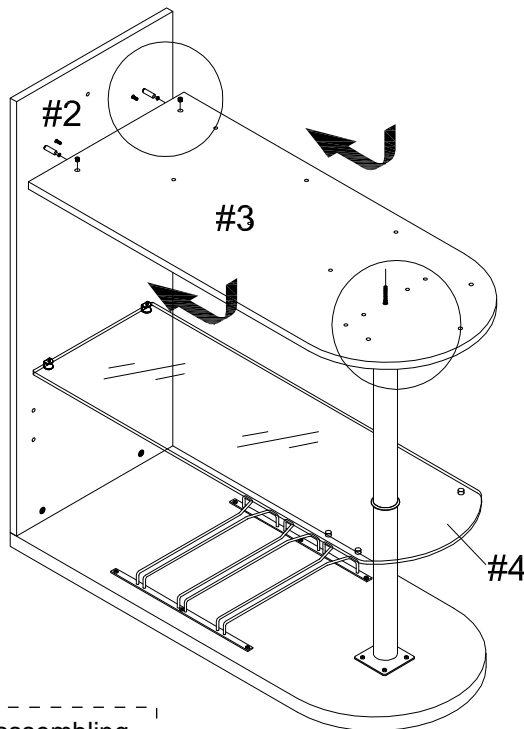

Note: Be cautious while assembling this step and make sure the glass shelf does not fall or get damaged.

2. Insert two cam locks (#L) into the large pre-drilled holes along the side of the bottom panel (#3). Once inserted, insert the end pre-drilled holes onto the ends of the cam bolts (#K) and wood dowels (#M). Lock cam lock (#L) using a Phillips screwdriver.



Insert a total of 2 stud bolts (#P) into the two outer pre-drilled holes as shown. Turn right to tighten. Then apply a leg (#10) onto each bolt and right to tighten.

#P x 2pcs

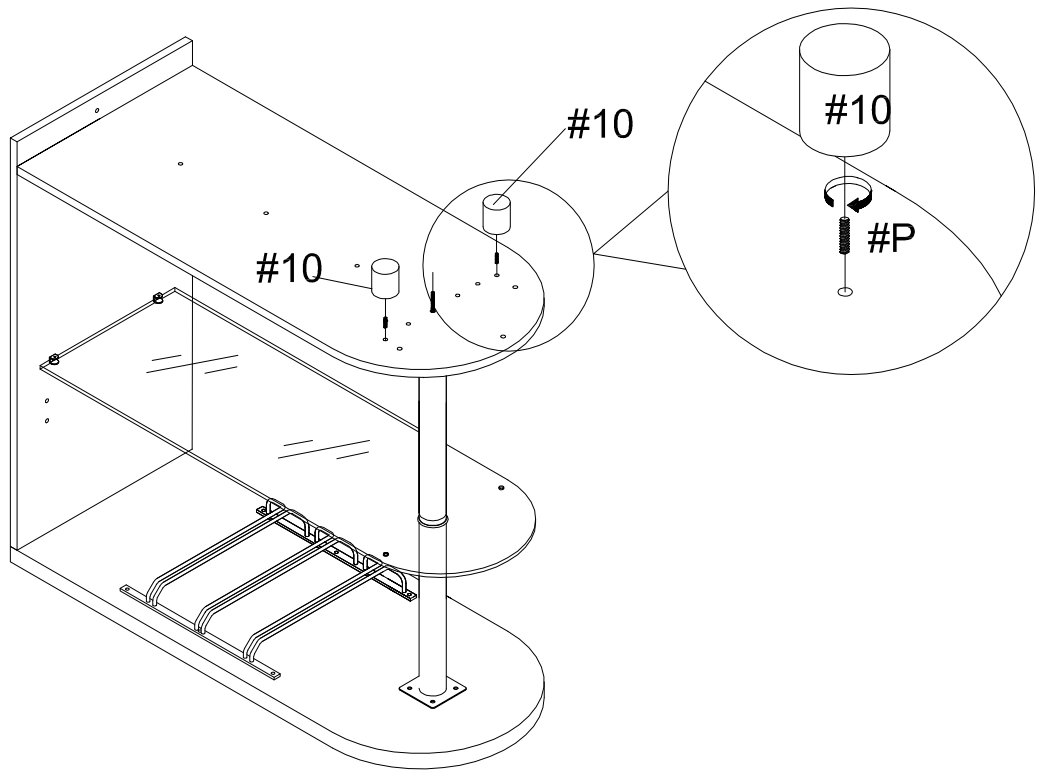

2. Insert a total of 3 bolts (#D) into the pre-drilled holes along the top of the bottom support tube A (#12). Secure using the Allen wrench (#H).

#B x 1pc  
#D x 7pcs  
#E x 1pc  
#F x 1pc  
#G x 2pcs

1. Align one end of the bottom support tube A (#12) to the hole along the top of the side panel (#2). Apply a flat washer (#G) onto a bolt (#D) and insert into the hole on the outer side of the side panel and secure using the Allen wrench (#H). Then apply a flat washer (#G) onto a bolt (#B) and insert into the hole on the inner side and secure using the Allen wrench (#H).

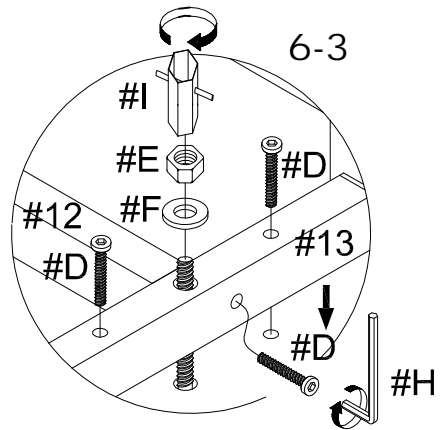
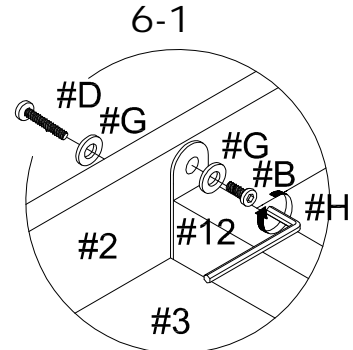
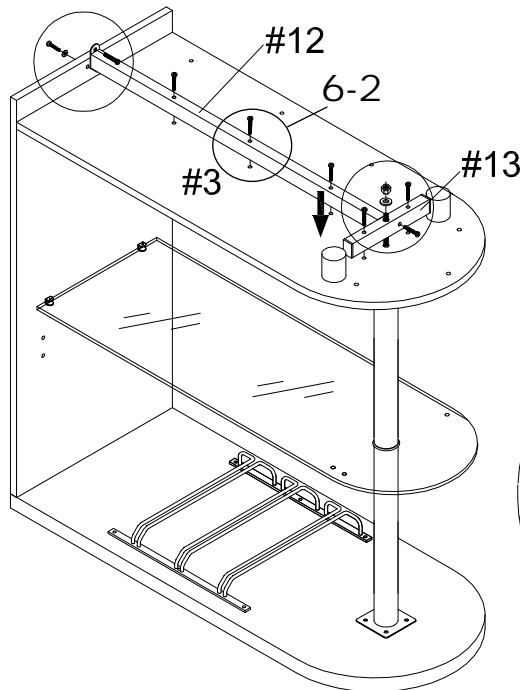

3. Apply bottom support tube B (#13) onto the stud bolt (#J). Apply a flat washer (#F) then hex nut (#E) onto the stud bolt (#J), in that order. Secure using the wrench (#I). Insert a total of 3 bolts (#D) into the remaining holes on (#13) and secure using the Allen wrench (#H).



#B x 3pcs  
#C x 2pcs  
#G x 5pcs

1. Prepare 3 bolt assemblies by inserting a flat washer (#G) onto bolts (#B). Then align the bottom panel guardrail (#8) to the pre-drilled holes on the bottom of the bottom panel (#3). Insert bolt assemblies from the top and secure using the Allen wrench (#H).

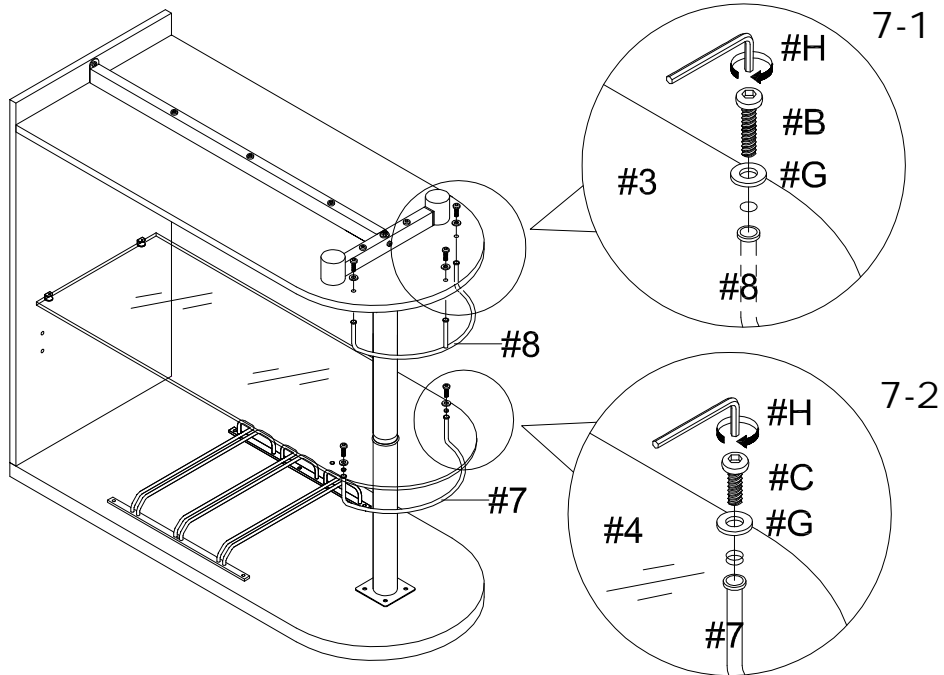

2. Prepare 2 bolt assemblies by inserting a flat washer (#G) onto bolts (#C). Then align the glass shelf guardrail (#7) to the pre-drilled holes on the bottom of the glass shelf (#4). Insert bolt assemblies from the top and secure using the Allen wrench (#H).



#B x 2pcs  
#C x 1pc  
#G x 1pc

Turn upright.

1. Align the end of the guardrail (#6) to the side panel (#2). Insert a total of 2 bolts (#B) and secure using the Allen wrench (#H).

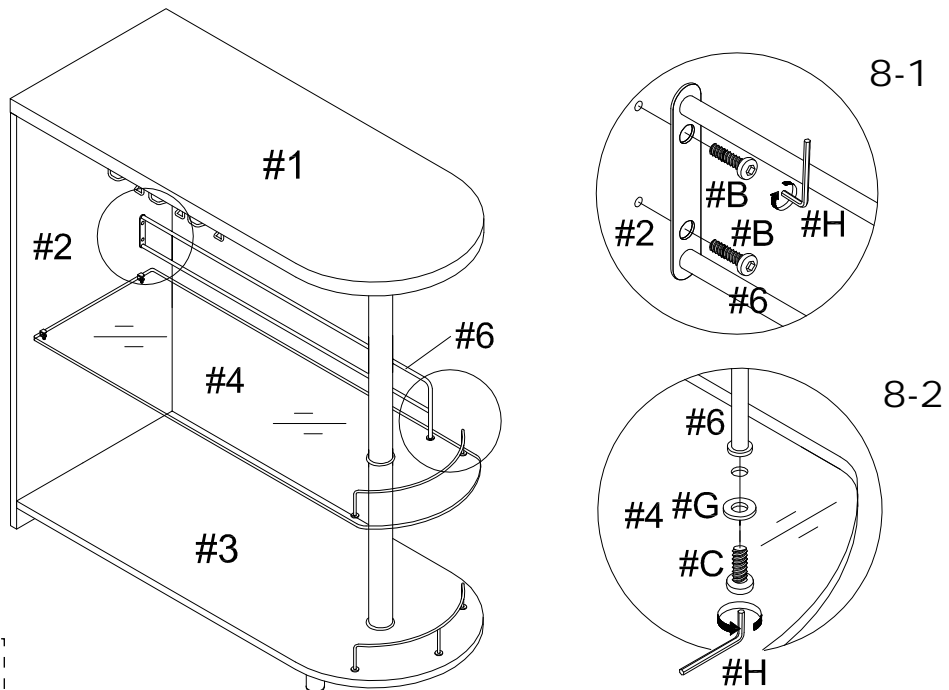

Warning: Be extra careful when moving product.

2. Align the other end to the pre-drilled hole on the glass shelf (#4). Insert a flat washer (#G) onto bolt (#C), then insert bolt assembly into hole and secure using the Allen wrench (#H).

ASSEMBLY IS COMPLETED