



**Furniture of America**<sup>®</sup>

E-Commerce by Enitial Lab

# ASSEMBLY INSTRUCTIONS

MODEL #

**CM-BT6464**

Questions?

GIVE US CALL: 1-888-980-5122  
MON-FRI 8:30AM - 5:30PM (PST)

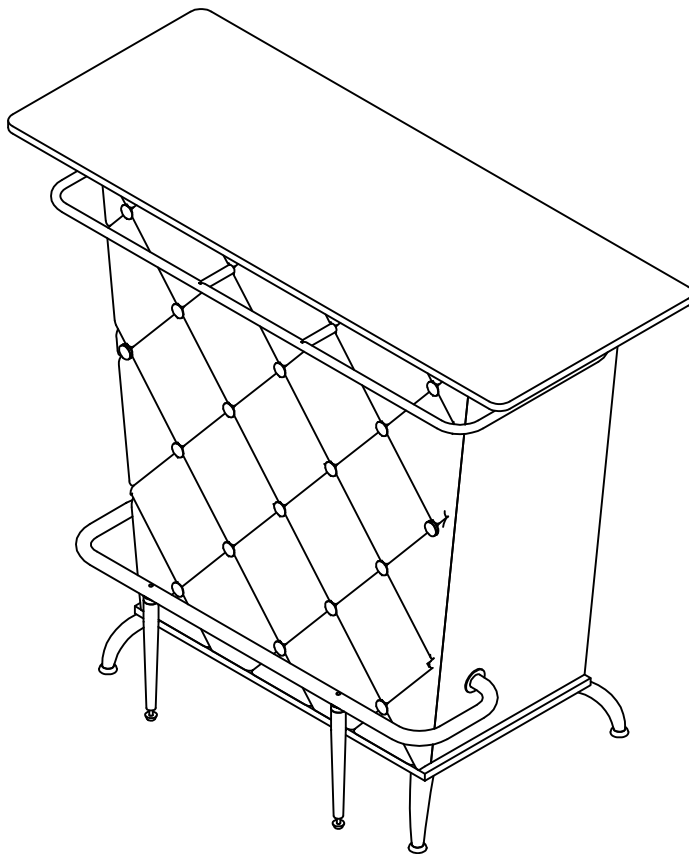

## TOOLS REQUIRED



**Allen Wrench**

(Included)



**Phillips  
Screwdriver**

(Not Included)



**2 - People  
Recommended**

## ASSEMBLY RATING



EASY —————> DIFFICULT

The Assembly Rating is a 5-point system showing the level of effort needed to assemble a specific product.

VERSION # 20-08-27





FOA Intro

Thank you for your purchase!

We hope you enjoy this new addition to your home for many years to come.

Our commitment to providing quality products does not simply end when you purchase our product. We fully stand behind our products from start to finish. Our customer service department is available Monday – Friday 8:30 AM – 5:30 PM Pacific and can help with assembly questions as well as, if necessary, replacing damaged or missing parts. To help expedite our service, please have these assembly instructions readily available, along with your order receipt.

 **Consumer Hotline**  
Toll-Free 1-888-980-5122

 **Monday to Friday**  
8:30AM- 5:30PM (PST)

 **WEBSITE**  
[www.foagroup.com](http://www.foagroup.com)

 **E-MAIL**  
[cs.ec@foagroup.com](mailto:cs.ec@foagroup.com)

    foagroup

 FurnitureOfAmerica

---

## CHECK BEFORE STARTING

**Are you missing anything?**

Double-check all parts, hardware and accessories listed on Page 6 are accounted for.

**Check out our Quick Tips!**

We recommend reviewing the pre-assembly handouts. Even experts need a refresher now and then!

**Should we send any replacements?**

Are there any irregularities or flaws in the parts? We can send replacements!

**Prep Time!**

Please review the assembly instructions and all diagrams prior to assembling. Arrange parts as recommended on Page 7 and group identical hardware together to make assembling easier.

# PRE ASSEMBLY INTRODUCTION

We understand building ready-to-assemble furniture can be a challenging experience for some. To help avoid confusion, we have provided some helpful tips that may speed up the process.

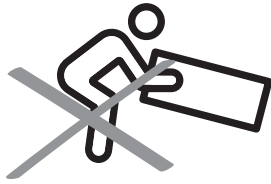

## Teamwork

ALWAYS have at least two people to help with transporting and assembling the product to avoid potential injury and/or damage.

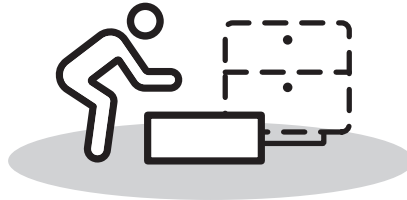
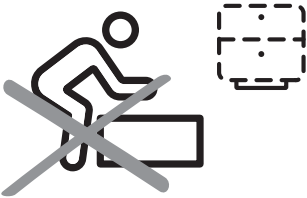

## Suitable Location

Assembling near the area of the intended location is highly recommended.



## Sufficient Space

Make sure you have enough space to move around during the assembly.



## Avoid Scratches

Use cardboard, blankets or a carpeted area while assembling furniture to prevent scratches.

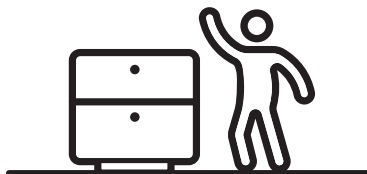
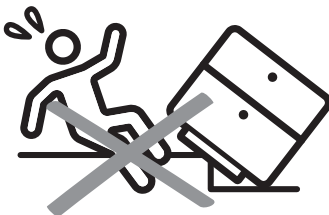

## Flat Surface

Make sure the furniture rests on a flat and level surface with each leg evenly touching the floor.

# ASSEMBLY AND CARE ADVICE



**FAILURE TO FOLLOW THE GUIDELINES BELOW MAY RESULT IN INJURY AND/OR PROPERTY DAMAGE.**



Position each part correctly and insert screws or bolts into their respective holes.



Turn clockwise to tighten and only tighten when step is completed or when instructed to do so.



Use the appropriate hand tools or power tools for assembly. Select steps, such as tightening screws and/or bolts, may require hand tools to avoid causing damage during assembly.



Save the instructions and store any supplied tools for later maintenance.



After two weeks, check and tighten any loose hardware and repeat again every six months thereafter.

**IT IS THE USER'S RESPONSIBILITY TO MAINTAIN THE FURNITURE. THE HARDWARE MAY LOOSEN OVER TIME AND MAY CAUSE THE FURNITURE TO BE WOBBLY AND UNABLE TO SUPPORT ITS INTENDED WEIGHT CAPACITY. THIS MAY LEAD TO COLLAPSE AND MAY CAUSE SERIOUS INJURY.**

# CAM LOCK FASTENER ASSEMBLY INSTRUCTIONS

## Note :

Every cam lock bolt must have a cam lock connector in order to fasten the parts together.

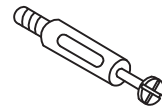

cam bolt



cam lock

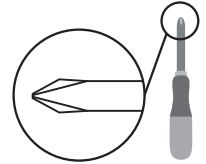

screwdriver

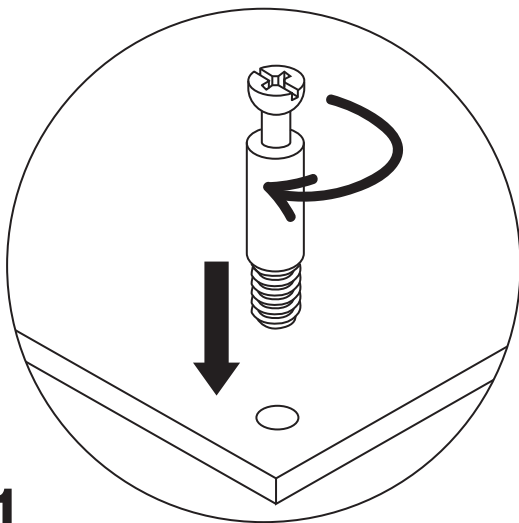

**1**

Screw the cam bolt into panel.

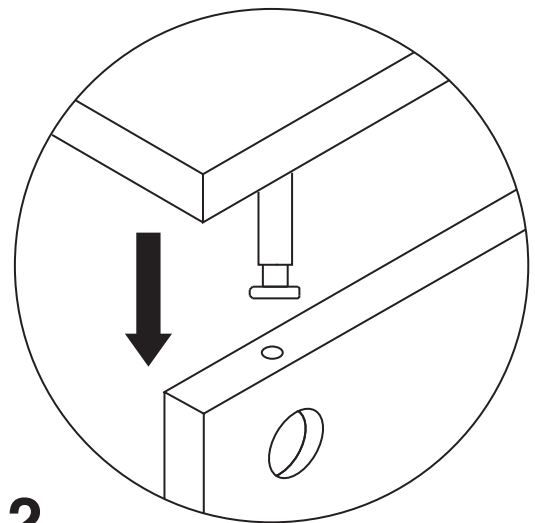

**2**

Insert the cam bolt into the bolt hole of joint panel.

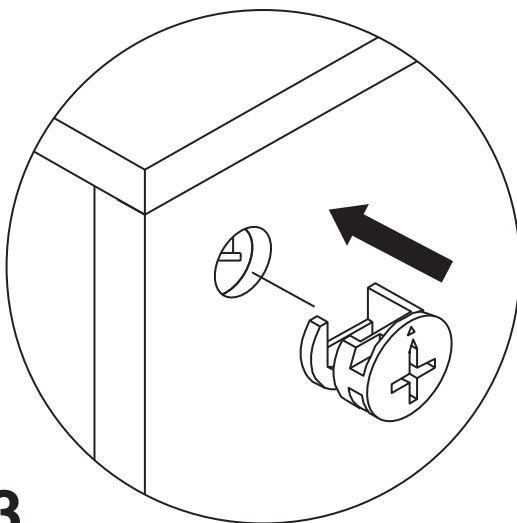

**3**

Align the cam lock with its side opening (or arrow) pointing to cam bolt.

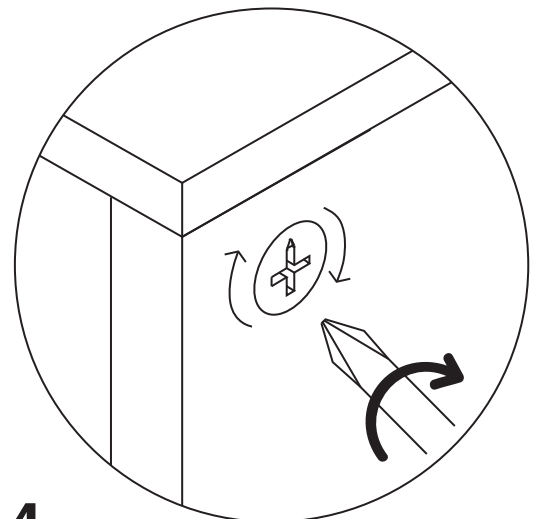

**4**

Turn the cam lock clockwise gently until it will not turn any more.

# BAR TABLE

CM-BT6464



- Please keep instructions for future reference.
- Check the quantity and irregularity of parts and hardware before you start.



## PARTS

#1 1pc

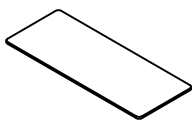

Top Panel

#2 1pc

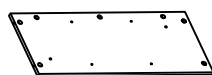

Left Side Panel

#3 1pc



Vertical Panel

#4 1pc

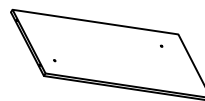

Right Side Panel

#5 1pc

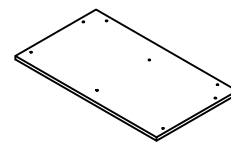

Base Panel

#6 1pc

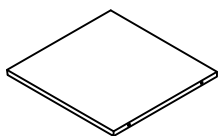

Left Shelf(UP)

#7 1pc

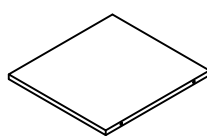

Left Shelf(DOWN)

#8 1pc

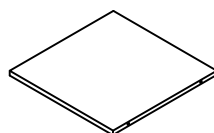

Right Shelf

#9 1pc

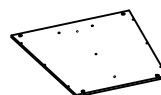

Front Panel

#10 1pc



Top Metal Tube

#11 1pc



Bottom Metal Tube

#12 2pcs



Support Leg

#13 2pcs

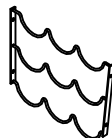

Bottom Metal Rack

#14 4pcs



Leg

#15 1pc



Top Metal Tube

# HARDWARE

#A 18pcs



Bolt 1/4"X5/8"

#B 4pcs



Bolt 1/4"X1-1/4"

#C 2pcs

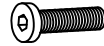

Bolt 1/4"X1-5/8"

#D 24 pcs



Flat Washer Ø13

#E 1pc



Allen Wrench M4

#F 16pcs

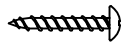

Wood Screw Ø4x16

#G 2pcs



Bolt 1/4"X1-5/8"

#H 37pcs



Cam Bolt

#I 37pcs



Cam-Lock

#J 2pcs



Middle Washer

## Exploded View

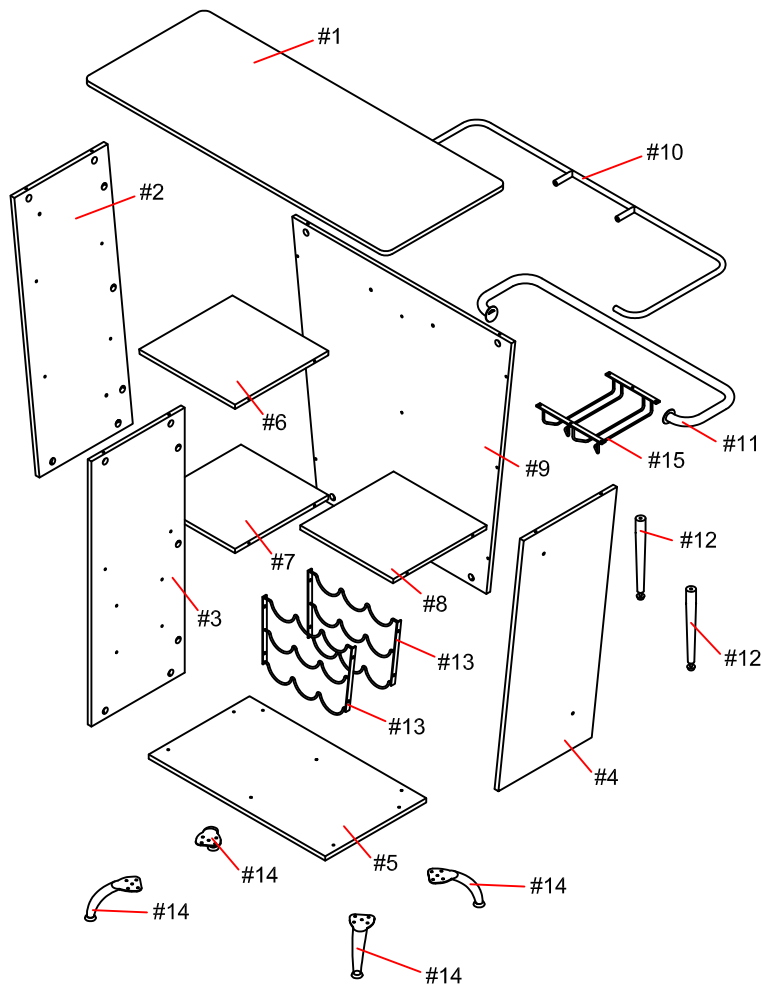

# ASSEMBLY INSTRUCTIONS

1) Attach cam bolts (#H) onto panels (#2,3,4).

## 1

- Part #2 x1pc
- Part #3 x1pc
- Part #4 x1pc
- Part #6 x1pc
- Part #7 x1pc
- Part #8 x1pc
- Hardware #H x12pcs
- Hardware #I x33pcs

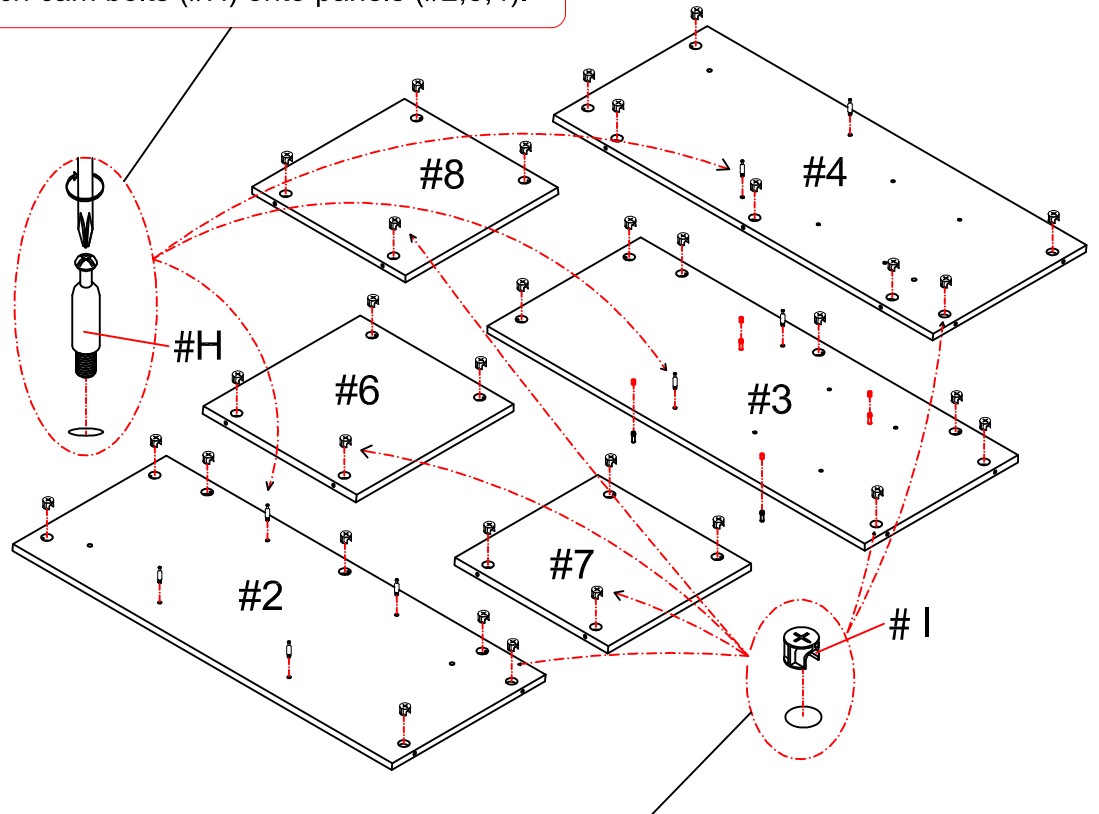

2) Attach cam locks (#I) into the holes of the panels above.

## 2

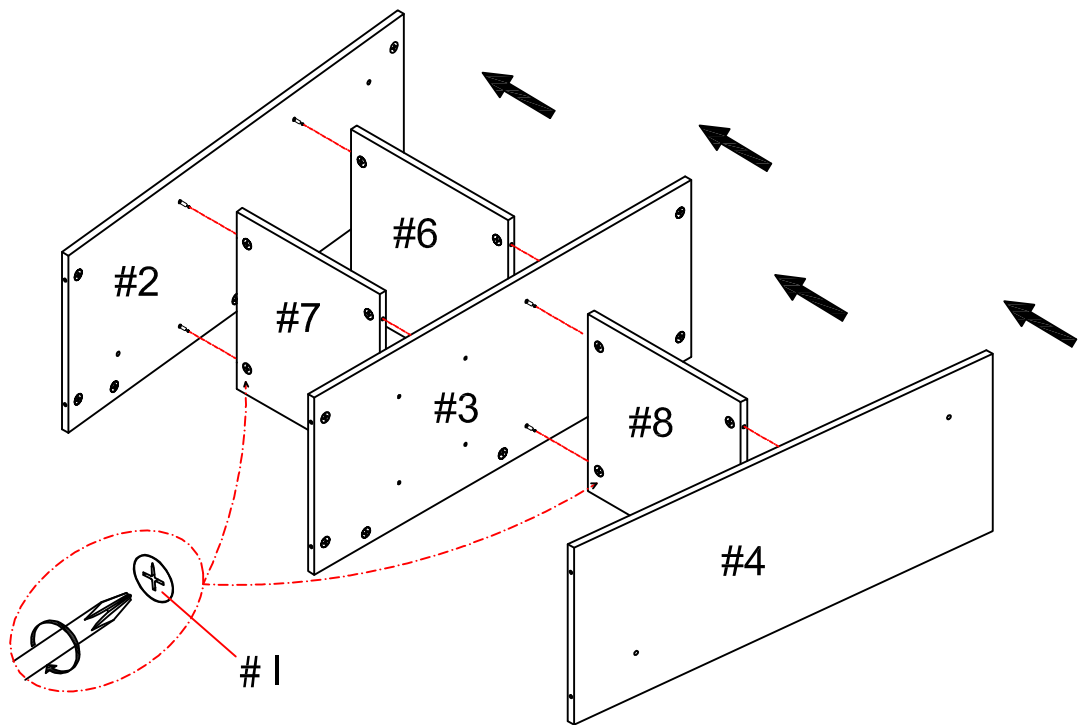

When attaching panels together, make sure to reference back to page 5 on how to properly fit cam bolts (#H) to cam locks (#I).



# ASSEMBLY INSTRUCTIONS

Align legs (#14) to the base panel (#5), then secure by using screws (#A,#F) and washer(#D).

## 3

- Part #14 x4pcs
- Hardware #A x4pcs
- Hardware #D x4pcs
- Hardware #F x 16pcs

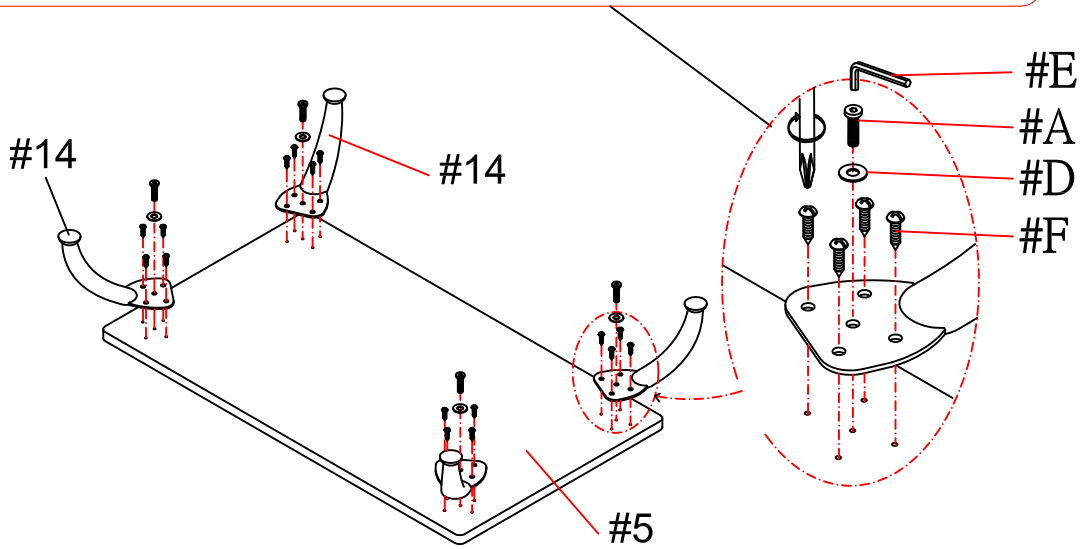

## 4

- Part #1 x1pc
- Part #9 x1pc
- Hardware #I x4pcs
- Hardware #H x25pcs

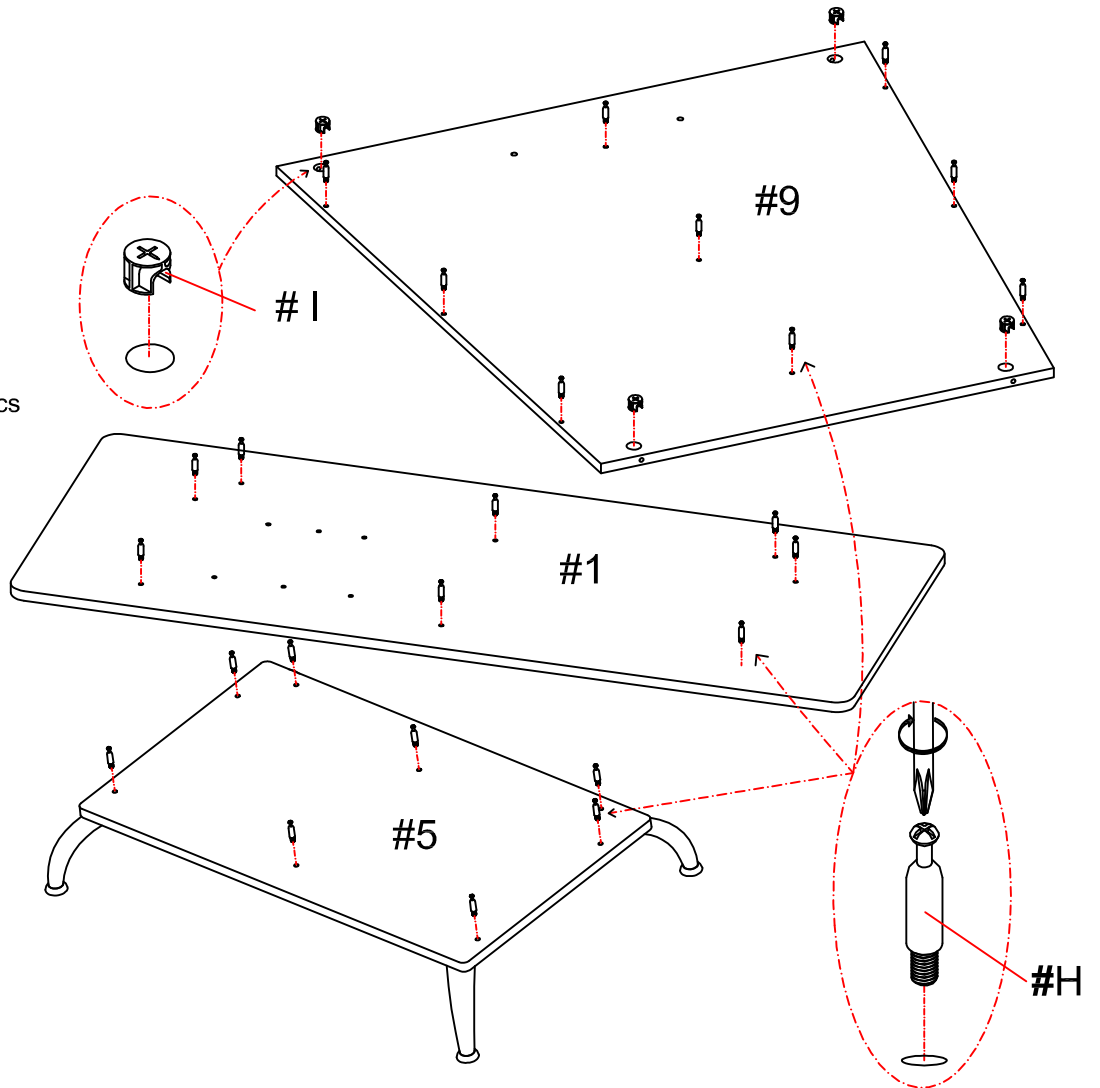

# ASSEMBLY INSTRUCTIONS

5

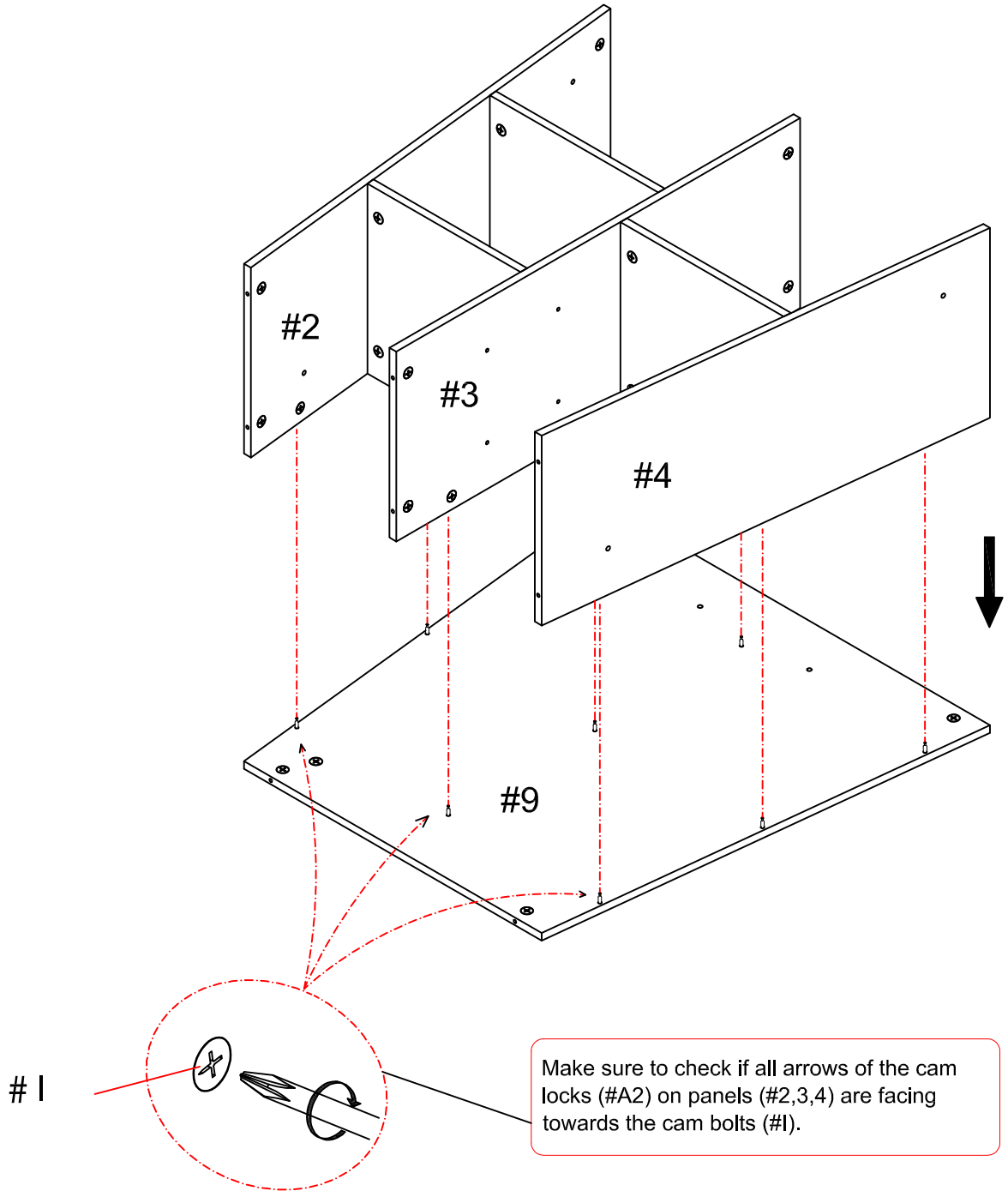



# ASSEMBLY INSTRUCTIONS

7

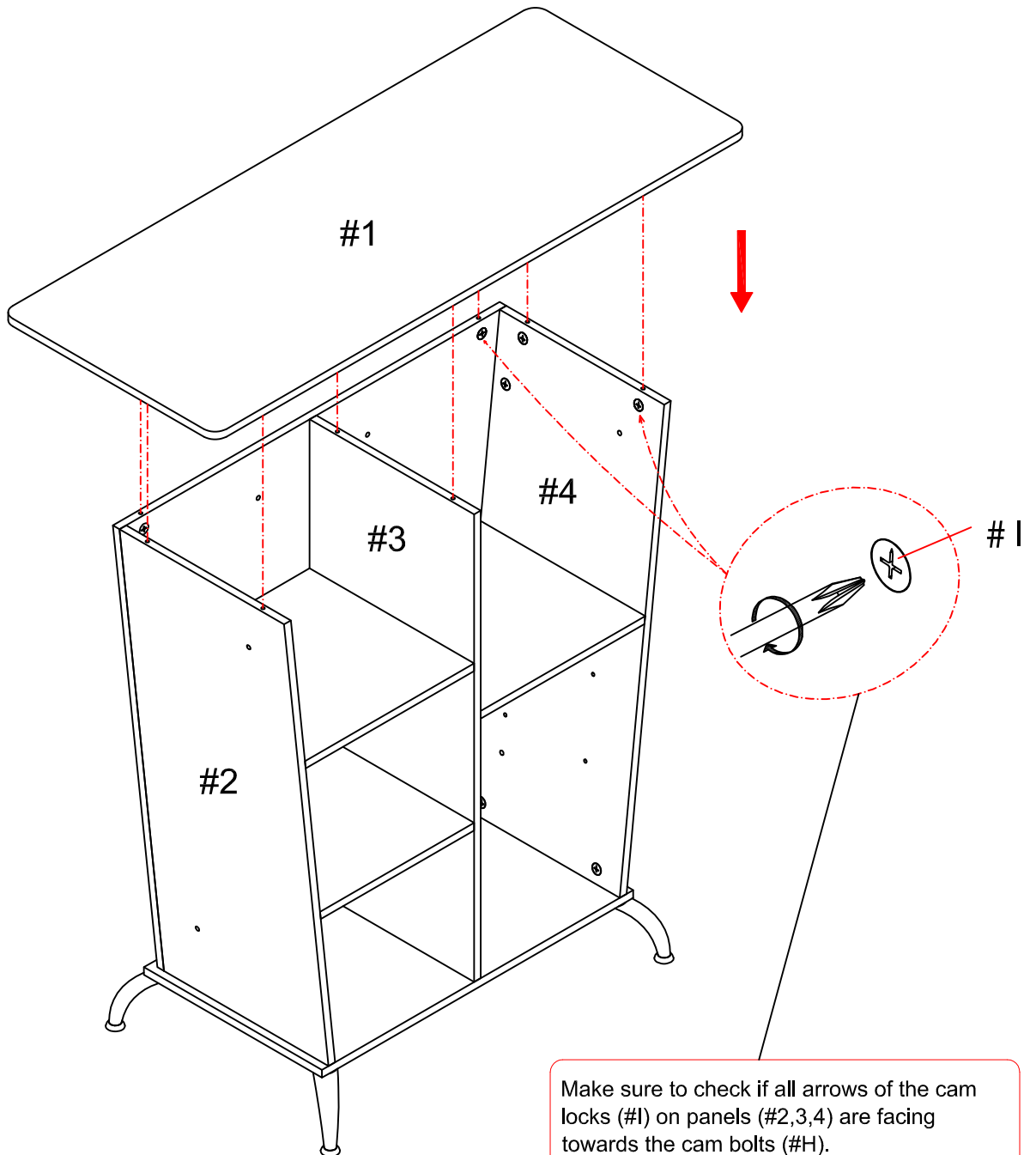

# ASSEMBLY INSTRUCTIONS

## 8

- Part #10 x1pc
- Hardware #C x2pcs
- Hardware #D x2pcs

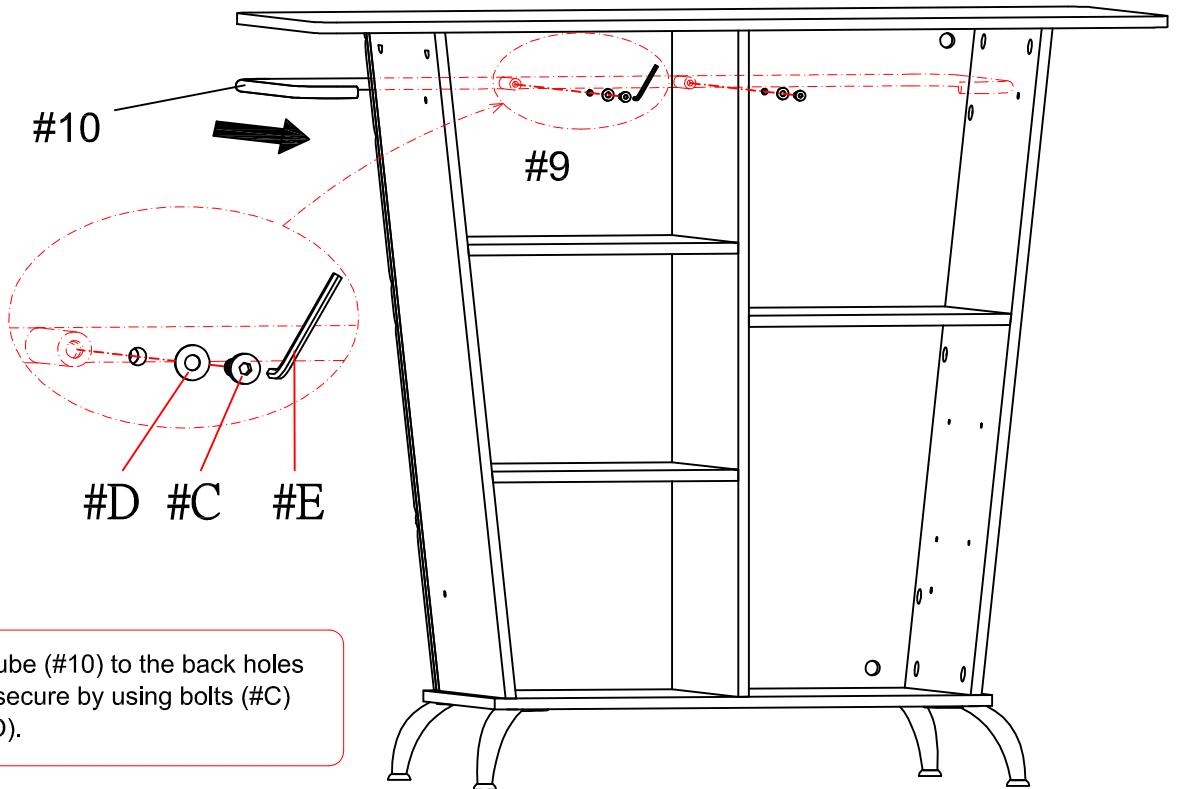

Align top metal tube (#10) to the back holes of the unit, then secure by using bolts (#C) with washers (#D).

## 9

- Hardware #B x2pcs
- Hardware #D x2pcs

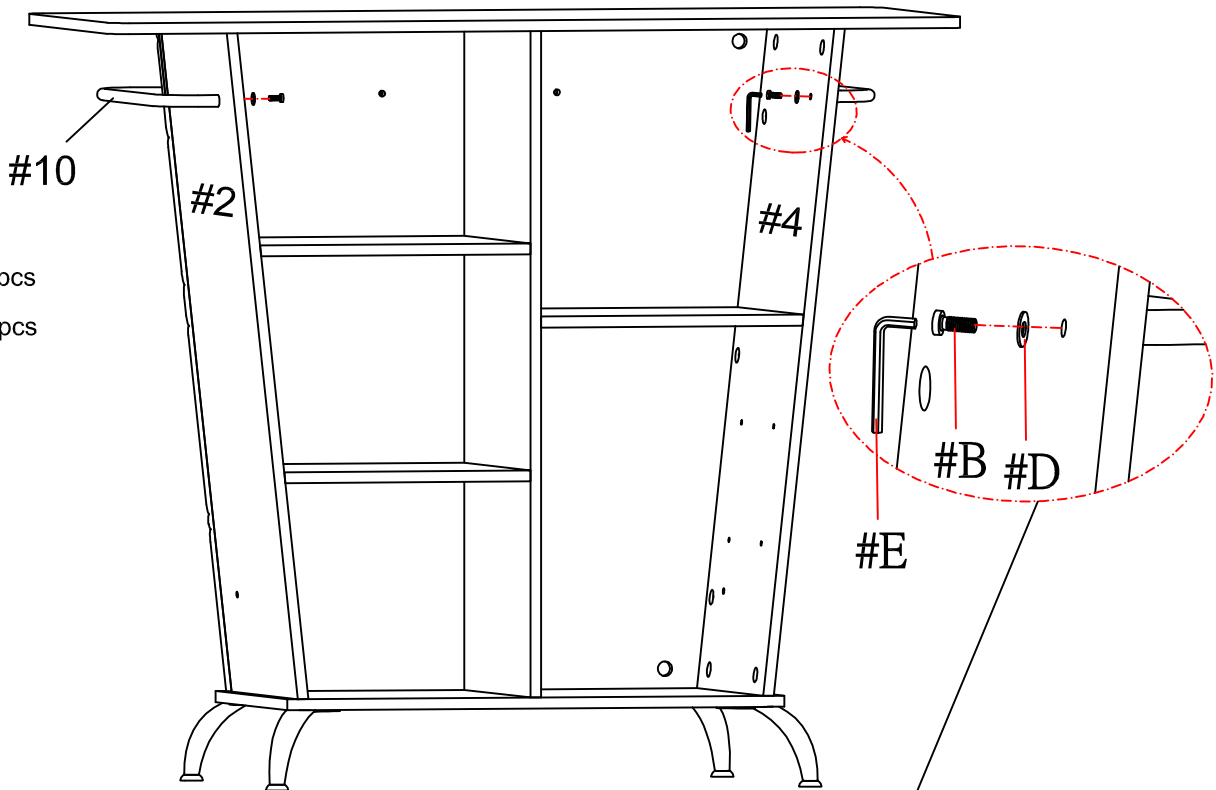

Secure metal tube (#10) to the side panels (#2,4) by using bolts (#B) with washers (#D).

# ASSEMBLY INSTRUCTIONS

## 10

Part #11 x1pc

Part #12 x2pcs

Hardware #J x2pcs

Hardware #G x2pcs

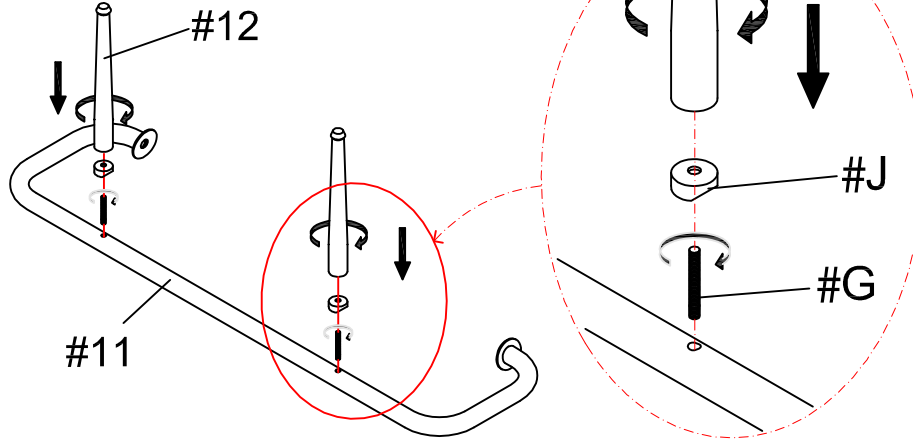

Attach bolts (#G) to the holes of the bottom metal tube (#11), then insert middle washers (#J) to the bolts (#G). Secure legs (#12) to the bolts (#G).

## 11

Hardware #B x2pcs

Hardware #D x2pcs

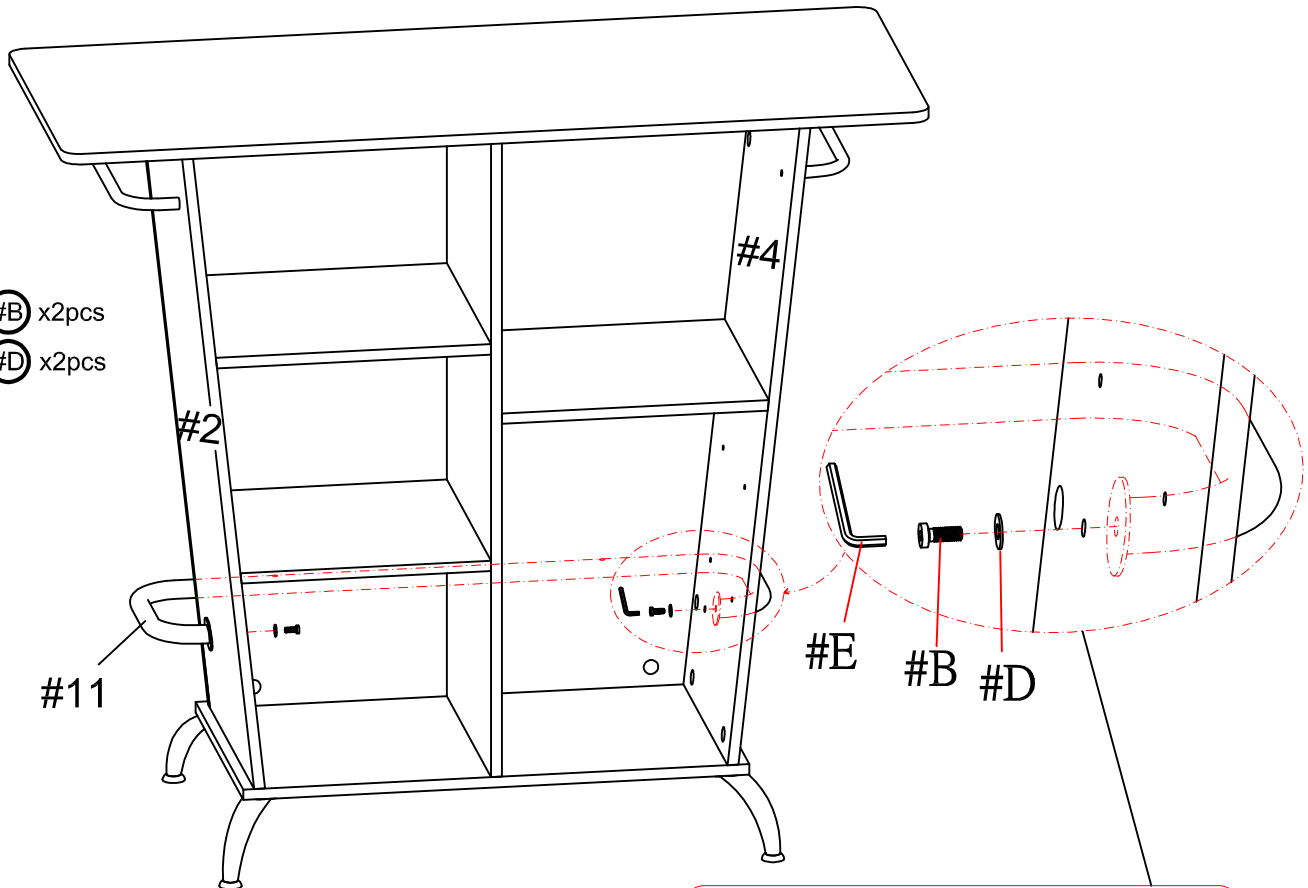

Align bottom metal tube (#11) to the side panels holes (#2, #4), then secure by using bolts (#B) with washers (#D).

# ASSEMBLY INSTRUCTIONS

## 12

Part #13 x2pcs

Part #15 x1pc

Hardware #A x14pcs

Hardware #D x14pcs

1) Align top metal rack (#15) to the holes of the top panel (#1), then secure by using bolts (#A) with washers (#D).

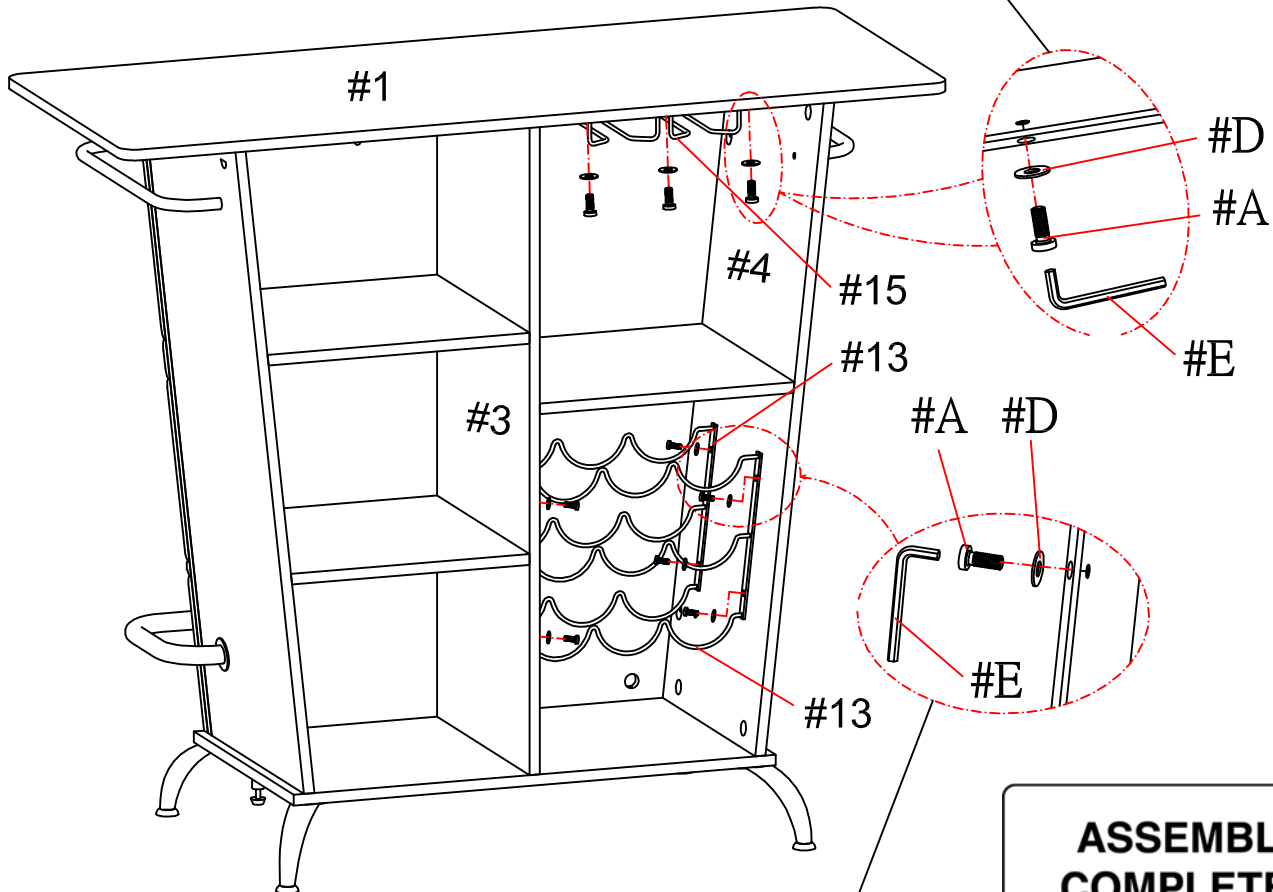

2) Align bottom metal racks (#13) to the holes of the unit, then secure by using bolts (#A) with washers (#D).

## ASSEMBLY COMPLETED



Please ensure the furniture rests on an even and flat surface. If the product wobbles or feels loose, double-check all bolts and/or screws are properly tightened and secured.

### ✓ Keep this handy!

Please retain this instruction manual and any order-related information for future reference.

### ✓ Lift, don't drag!

To avoid damage to product please always LIFT the product when transporting or adjusting the placement.