



Furniture of America[®]

E-Commerce by Enitial Lab

ASSEMBLY INSTRUCTIONS

MODEL #

CM-BK263

Questions?

GIVE US CALL: 1-888-980-5122
MON-FRI 8:30AM - 5:30PM (PST)

TOOLS REQUIRED



Allen Wrench

(Included)



Phillips Screwdriver

(Not Included)

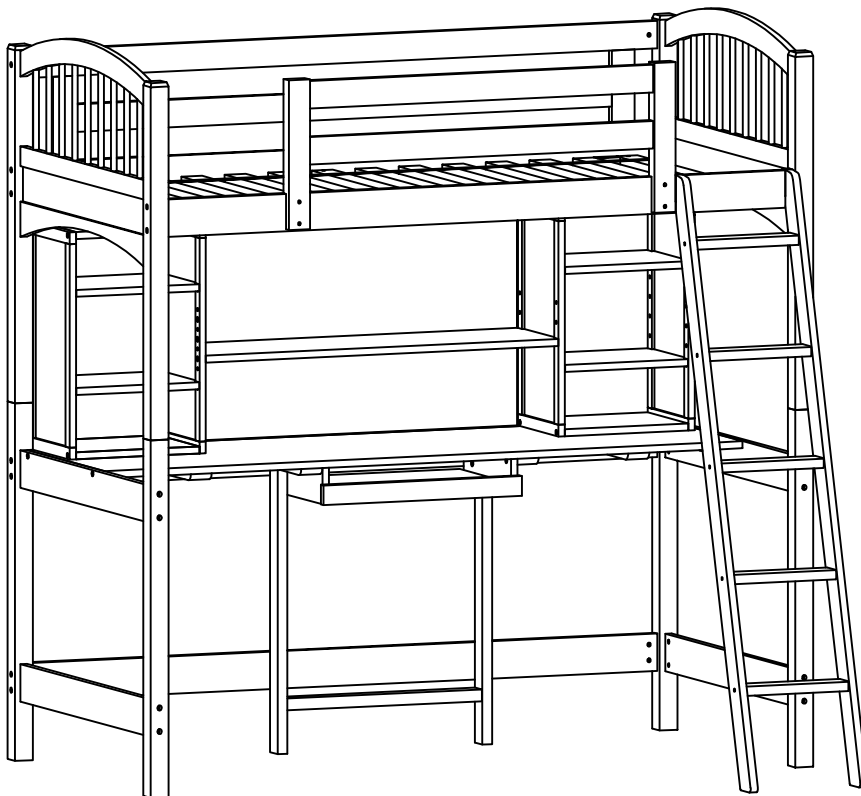

4 - People Recommended

ASSEMBLY RATING



EASY —————> DIFFICULT

The Assembly Rating is a 5-point system showing the level of effort needed to assemble a specific product.





FOA Intro

Thank you for your purchase!

We hope you enjoy this new addition to your home for many years to come.

Our commitment to providing quality products does not simply end when you purchase our product. We fully stand behind our products from start to finish. Our customer service department is available Monday – Friday 8:30 AM – 5:30 PM Pacific and can help with assembly questions as well as, if necessary, replacing damaged or missing parts. To help expedite our service, please have these assembly instructions readily available, along with your order receipt.

 **Consumer Hotline**
Toll-Free 1-888-980-5122

 **Monday to Friday**
8:30AM- 5:30PM (PST)

 **WEBSITE**
www.foagroup.com

 **E-MAIL**
cs.ec@foagroup.com

    foagroup

 FurnitureOfAmerica

CHECK BEFORE STARTING

Are you missing anything?

Double-check all parts, hardware and accessories listed on Page 6 are accounted for.

Check out our Quick Tips!

We recommend reviewing the pre-assembly handouts. Even experts need a refresher now and then!

Should we send any replacements?

Are there any irregularities or flaws in the parts? We can send replacements!

Prep Time!

Please review the assembly instructions and all diagrams prior to assembling. Arrange parts as recommended on Page 7 and group identical hardware together to make assembling easier.

PRE ASSEMBLY INTRODUCTION

We understand building ready-to-assemble furniture can be a challenging experience for some. To help avoid confusion, we have provided some helpful tips that may speed up the process.

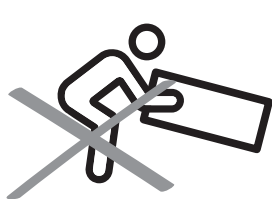

Teamwork

ALWAYS have at least two people to help with transporting and assembling the product to avoid potential injury and/or damage.

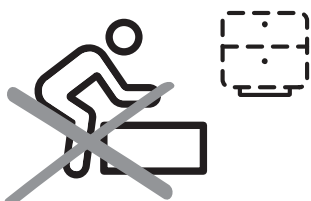

Suitable Location

Assembling near the area of the intended location is highly recommended.



Sufficient Space

Make sure you have enough space to move around during the assembly.

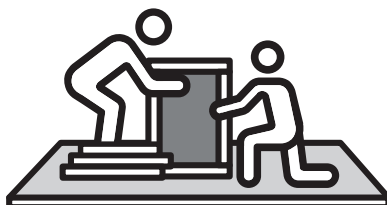

Avoid Scratches

Use cardboard, blankets or a carpeted area while assembling furniture to prevent scratches.



Flat Surface

Make sure the furniture rests on a flat and level surface with each leg evenly touching the floor.

ASSEMBLY AND CARE ADVICE



FAILURE TO FOLLOW THE GUIDELINES BELOW MAY RESULT IN INJURY AND/OR PROPERTY DAMAGE.



Position each part correctly and insert screws or bolts into their respective holes.



Turn clockwise to tighten and only tighten when step is completed or when instructed to do so.



Use the appropriate hand tools or power tools for assembly. Select steps, such as tightening screws and/or bolts, may require hand tools to avoid causing damage during assembly.



Save the instructions and store any supplied tools for later maintenance.



After two weeks, check and tighten any loose hardware and repeat again every six months thereafter.

IT IS THE USER'S RESPONSIBILITY TO MAINTAIN THE FURNITURE. THE HARDWARE MAY LOOSEN OVER TIME AND MAY CAUSE THE FURNITURE TO BE WOBBLY AND UNABLE TO SUPPORT ITS INTENDED WEIGHT CAPACITY. THIS MAY LEAD TO COLLAPSE AND MAY CAUSE SERIOUS INJURY.

TWIN BED/WORKSTATION

CM-BK263

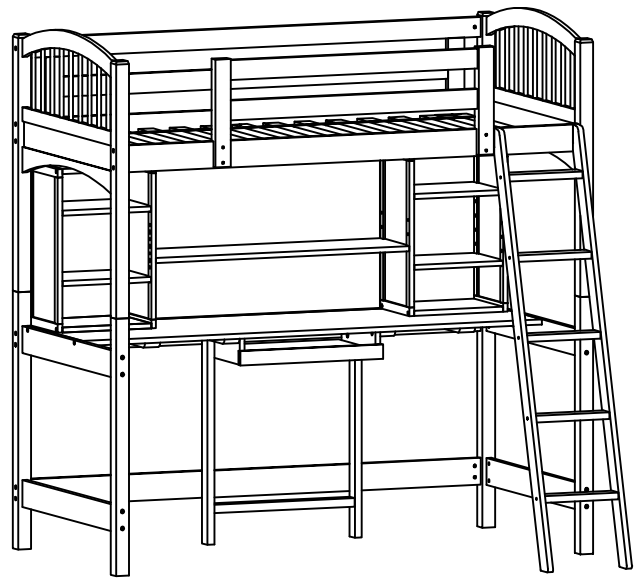
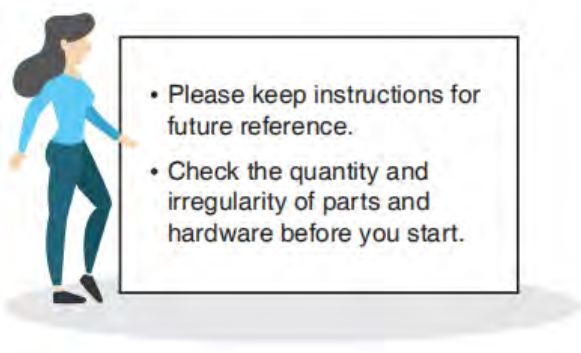

PARTS

#1 1pc

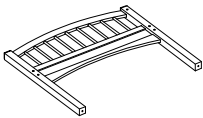

(Right) Headboard Panel

#2 1pc

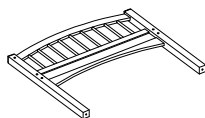

(Left) Headboard Panel

#3 1pc

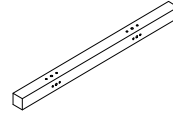

Left Leg

#4 1pc

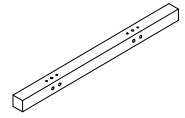

Right Leg

#5 2pcs

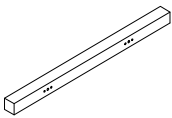

Front Legs

#6 1pc

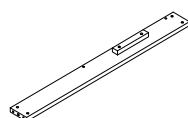

Middle Rail (Right)

#7 1pc

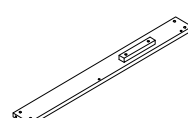

Middle Rail (Left)

#8 2pcs

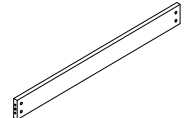

Lower Rails

#9 1pc

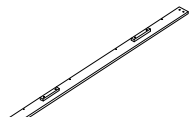

Back Middle Rail

#10 1pc

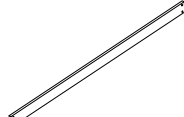

Lower Back Middle Rail

#11 1pc

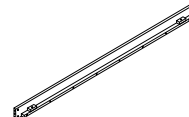

Upper Rail

#12 1pc

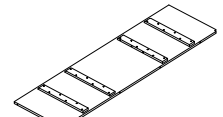

Big Shelf Panel

#13 1pc

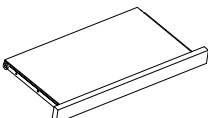

Key Board Shelf

#14 1pc

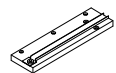

Right Glider

#15 1pc

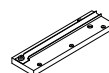

Left Glider

#16 1pc

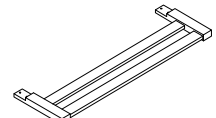

Front Guard Rail

TWIN BED/WORKSTATION

CM-BK263



- Please keep instructions for future reference.
- Check the quantity and irregularity of parts and hardware before you start.

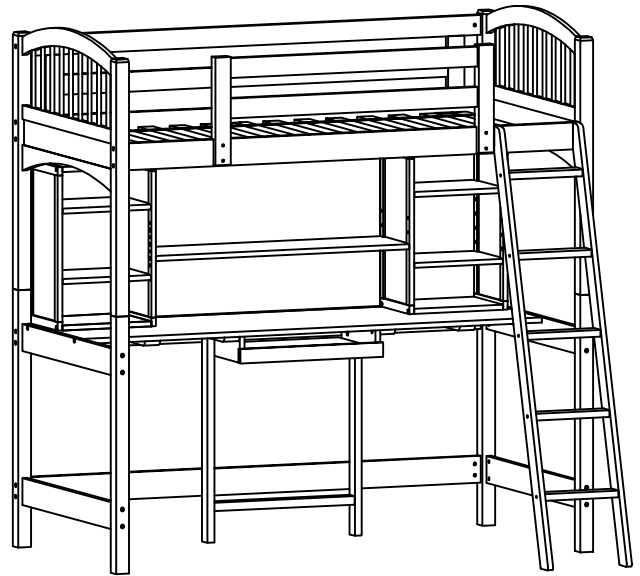

PARTS

#17 1pc

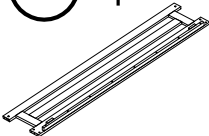

Back Guard Rail

#18 1pc

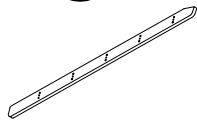

Ladder Slat (Right)

#19 1pc

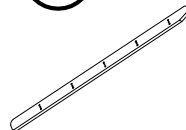

Ladder Slat (Left)

#20 5pcs



Slats of Ladder

#21 1pc

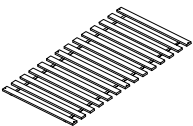

Slat Roll

#22 2pcs

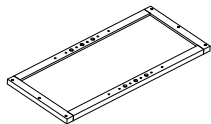

Left Vertical Shelf Panel

#23 2pcs

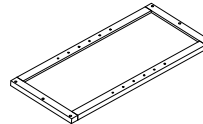

Right Vertical Shelf Panel

#24 4pcs

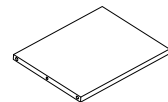

Side Fix Shelf Panel

#25 4pcs

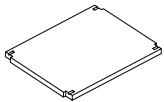

Adjustable Shelf Panel

#26 1pc

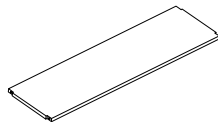

Middle Fix Shelf Panel

#27 2pcs

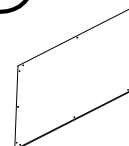

Back Shelf Panel

#28 1pc

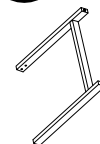

Sub Leg Frame

TWIN BED/WORKSTATION

CM-BK263

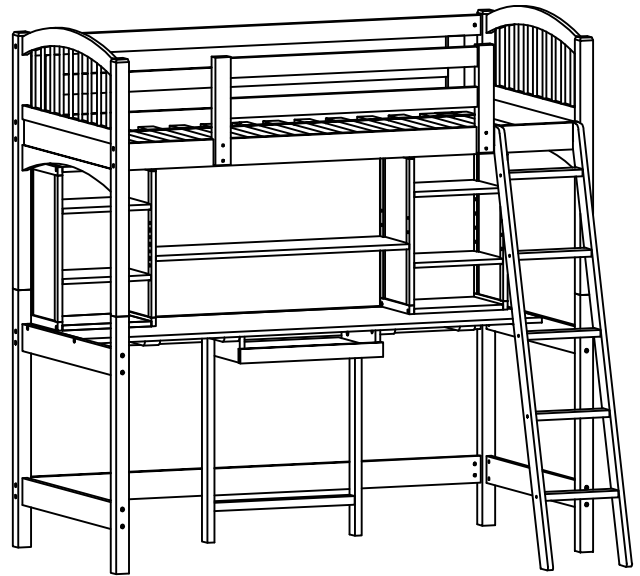
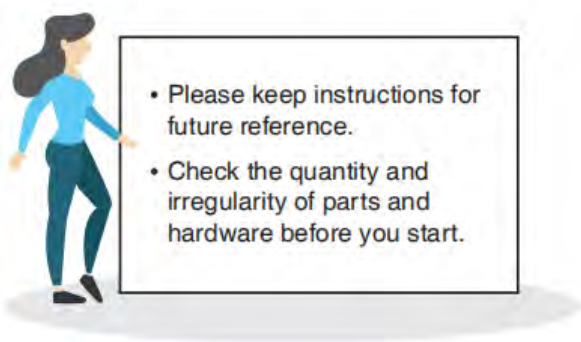

HARDWARE

#A 34pcs

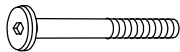

Bolt 1/4" x 3-3/8"

#D 8pcs



Wood Dowel 5/16" x 1-3/16"

#G 4pcs



Bolt 5/16" x 1-3/16"

#J 24pcs



Screw Ø1/8" x 19/32"

#M 16pcs



Shelf Pins

#P 10pcs

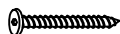

JCBC Screw Ø9/32" x 31/32"

#B 34pcs



Barrel Nut Ø1/4" x 1/2"

#E 8pcs

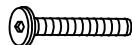

Bolt 1/4" x 1-9/16"

#H 6pcs

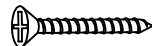

Screw Ø5/32" x 1-3/16"

#K 2pcs



Base For Ladder

#N 4pcs



Dowel Metal Ø3/8" x 4-15/16"

#C 2pcs



Allen Wrench

#C 40pcs



Wood Dowel Ø3/8" X 1-9/16"

#F 30pcs



Bolt 1/4" x 1-3/16"

#I 14pcs

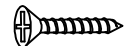

Screw Ø1/8" x 13/16"

#L 4pcs













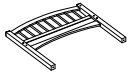
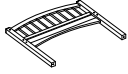
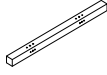
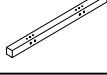
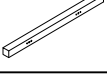
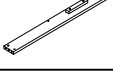
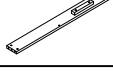
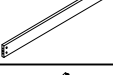

Corner Bracket

#O 34pcs

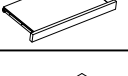

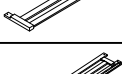

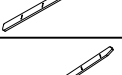
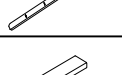





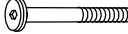









Wood Knob

CM-BK263 is packed in 3 cases

Carton	Designation	Part	Hardware
CMBK263 - 1	Headboard Left	#1	
	Headboard Right	#2	
	Leg Left	#3	
	Leg Right	#4	
	Leg (Front)	#5	 x 2
	Middle Rail (Right)	#6	
	Middle Rail (Left)	#7	
	Lower Rails	#8	 x 2
	Sub Leg Frame	#28	
CMBK263 - 2	Back Middle Rails	#9	
	Lower Back Middle Rails	#10	
	Upper Rails	#11	
	Big Shelf Panel	#12	
	Key Board Shelf	#13	
	Right Glider	#14	
	Left Glider	#15	
	Front Guard Rails	#16	
	Back Guard Rails	#17	
	Ladder Slat (Right)	#18	
	Ladder Slat (Left)	#19	
	Slat of Ladder	#20	 x 5

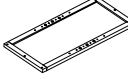
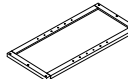
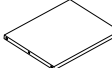
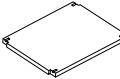
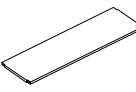
CM-BK263 is packed in 3 cases

Carton	Designation	Part		Hardware
CMBK263 - 3	Slat Roll	#21		 #A x 34pcs  #B x 34pcs  #C x 40pcs  #D x 8pcs  #E x 8pcs  #F x 30pcs  #G x 4pcs  #H x 6pcs  #I x 14pcs  #J x 24pcs  #K x 2pcs  #L x 4pcs  #M x 16pcs  #N x 4pcs  #O x 34pcs  #P x 10pcs  #Q x 2pcs
	Vertical Shelf Panel (Left)	#22	 x 2	
	Vertical Shelf Panel (Right)	#23	 x 2	
	Side Fix Shelf Panel	#24	 x 4	
	Adjustable Shelf Panel	#25	 x 4	
	Middle Fix Shelf Panel	#26		
	Back Shelf Panel	#27	 x 2	

Exploded View

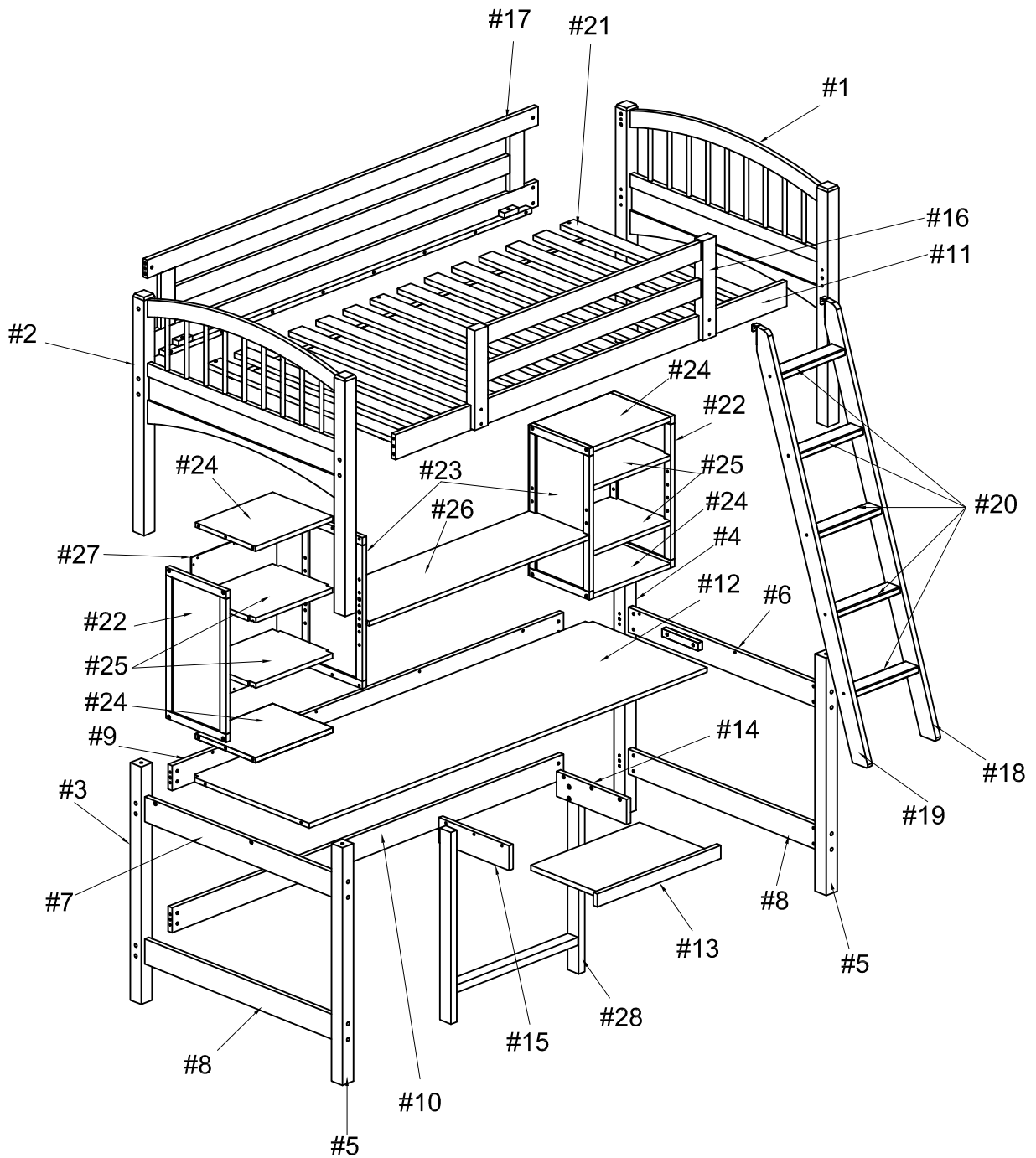

ASSEMBLY INSTRUCTIONS

1

Insert dowels (#C) to rails (#6,7,8). Align rails (#6,7,8) to legs (#3,4,5), then secure by using bolts (#A) onto barrel nuts (#B).

- Part #3 x1pc
- Part #4 x1pc
- Part #5 x2pcs
- Part #6 x1pc
- Part #7 x1pc
- Part #8 x2pcs
- Hardware #A x16 pcs
- Hardware #B x16 pcs
- Hardware #C x8 pcs

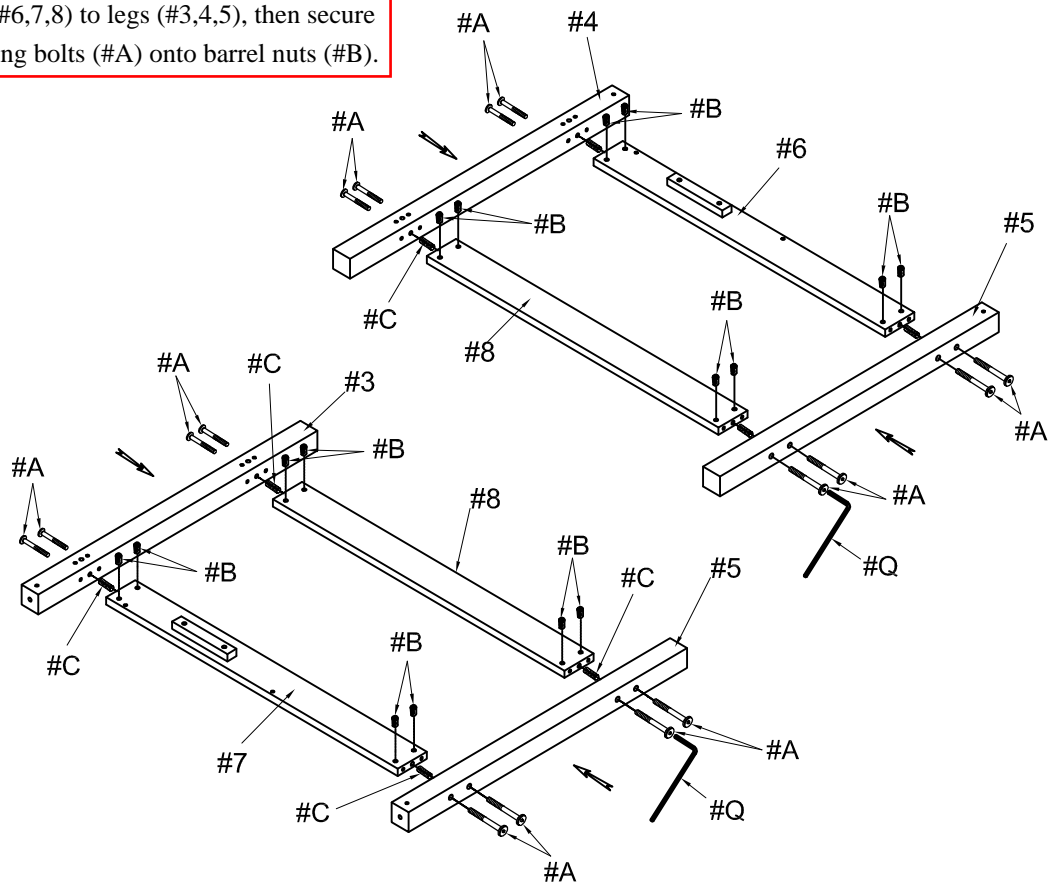

2

- Part #9 x1pc
- Part #10 x1pc
- Hardware #A x8 pcs
- Hardware #B x8 pcs
- Hardware #C x4 pcs

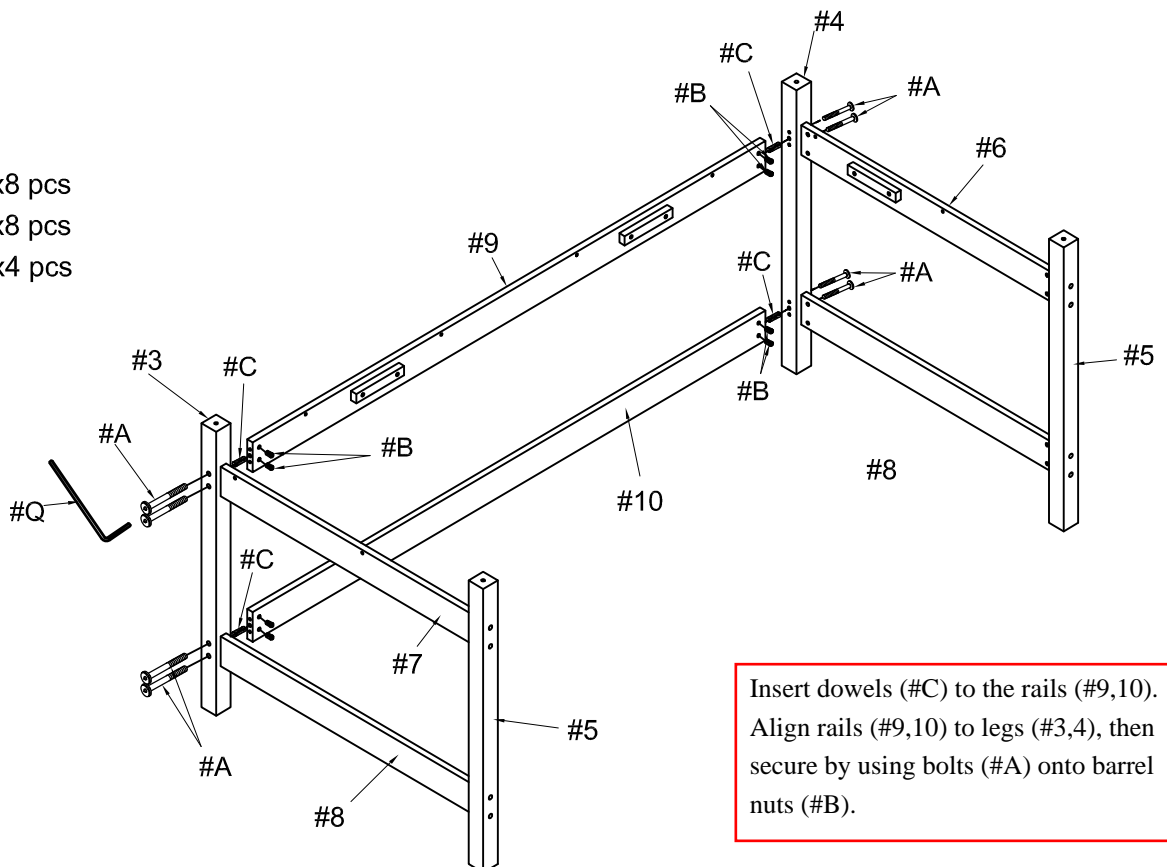

Insert dowels (#C) to the rails (#9,10). Align rails (#9,10) to legs (#3,4), then secure by using bolts (#A) onto barrel nuts (#B).

ASSEMBLY INSTRUCTIONS

Align gliders (#14,15) to the shelf panel (#12), then secure by using bolts (#F).

3

- Part #12 x1pc
- Part #14 x1pc
- Part #15 x1pc
- Hardware #F x6 pcs

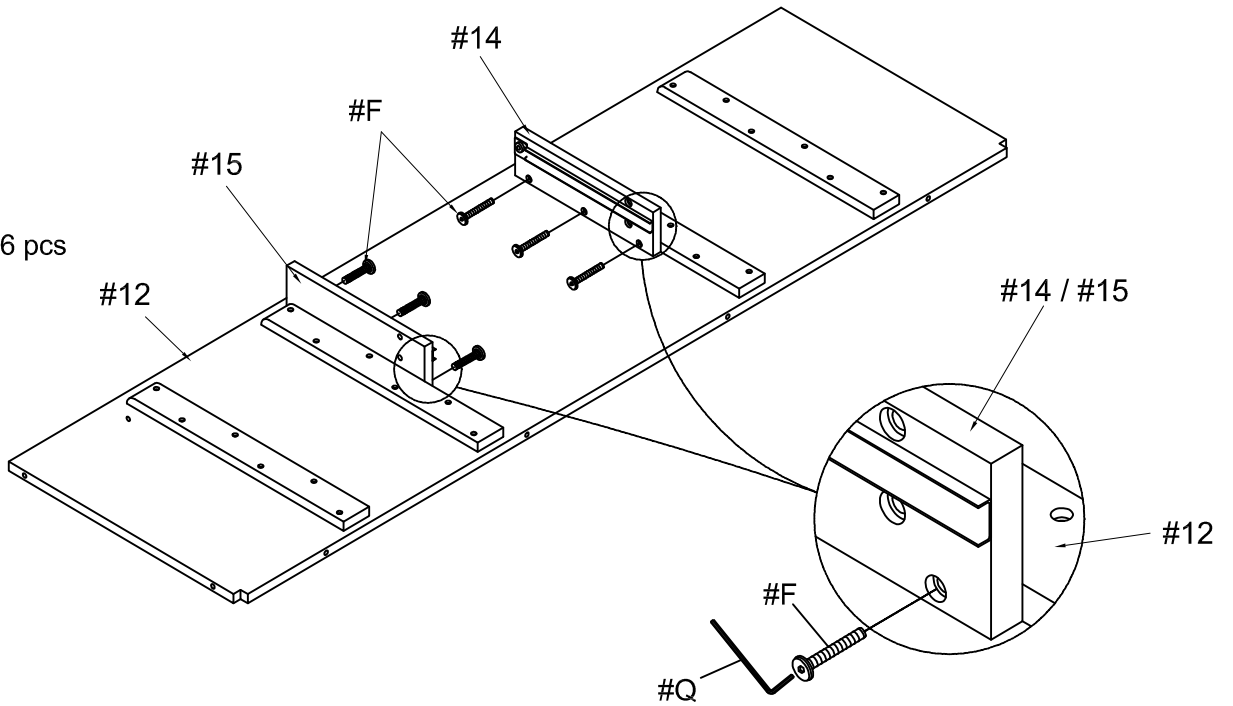

Align leg frame (#28) to shelf panel (#12), then secure by using bolts (#G).

4

- Part #28 x1pc
- Hardware #G x 4 pcs

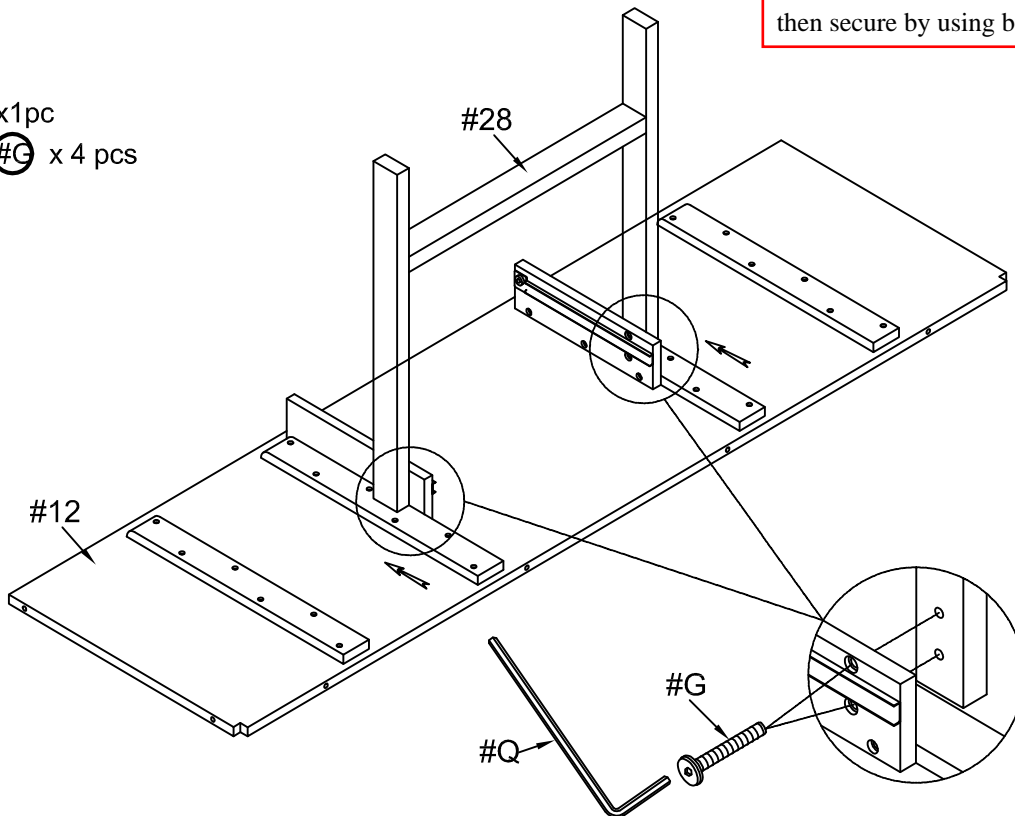

ASSEMBLY INSTRUCTIONS

5

Hardware #E x8 pcs

Hardware #G x4 pcs

Align shelf panel (#12) to the frames, then secure by using bolts (#E,G) as shown in the diagram.

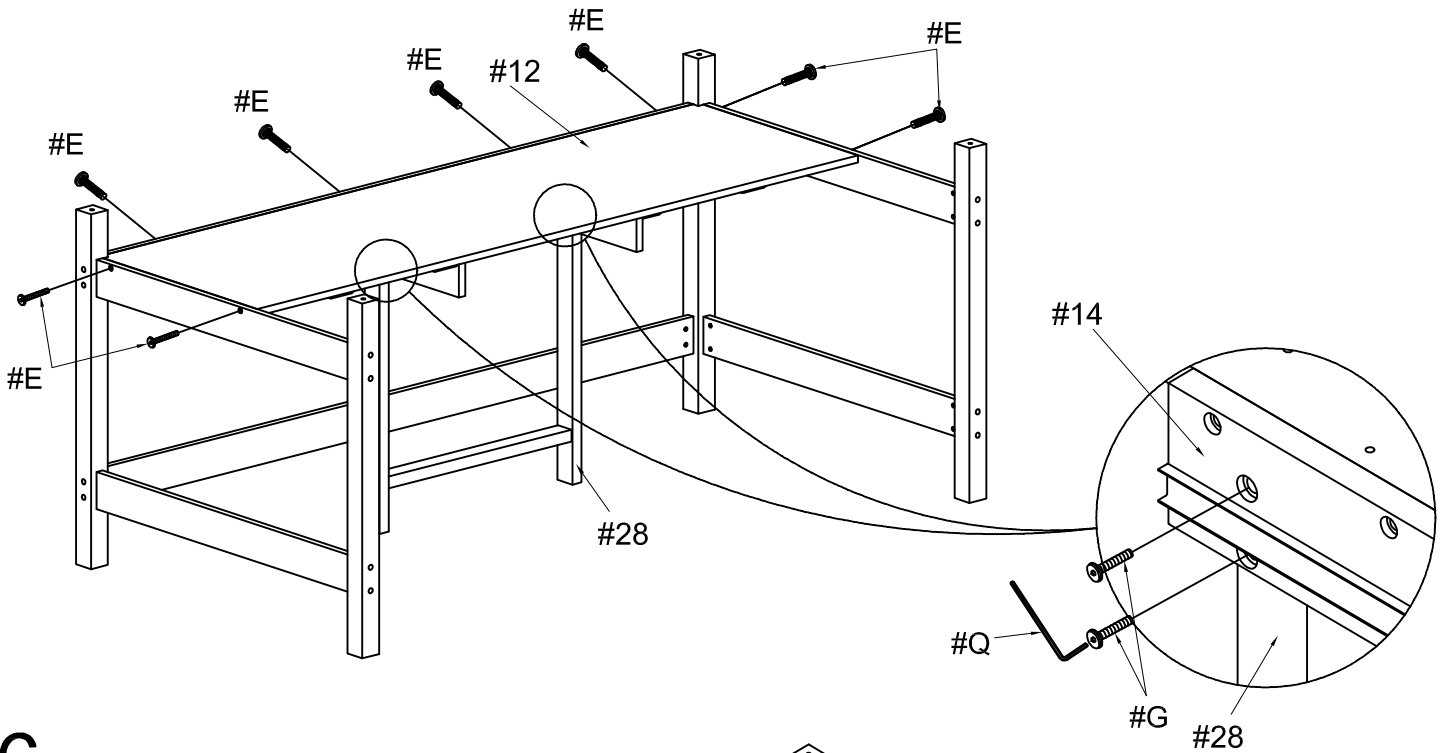

6

Part #13 x1pc

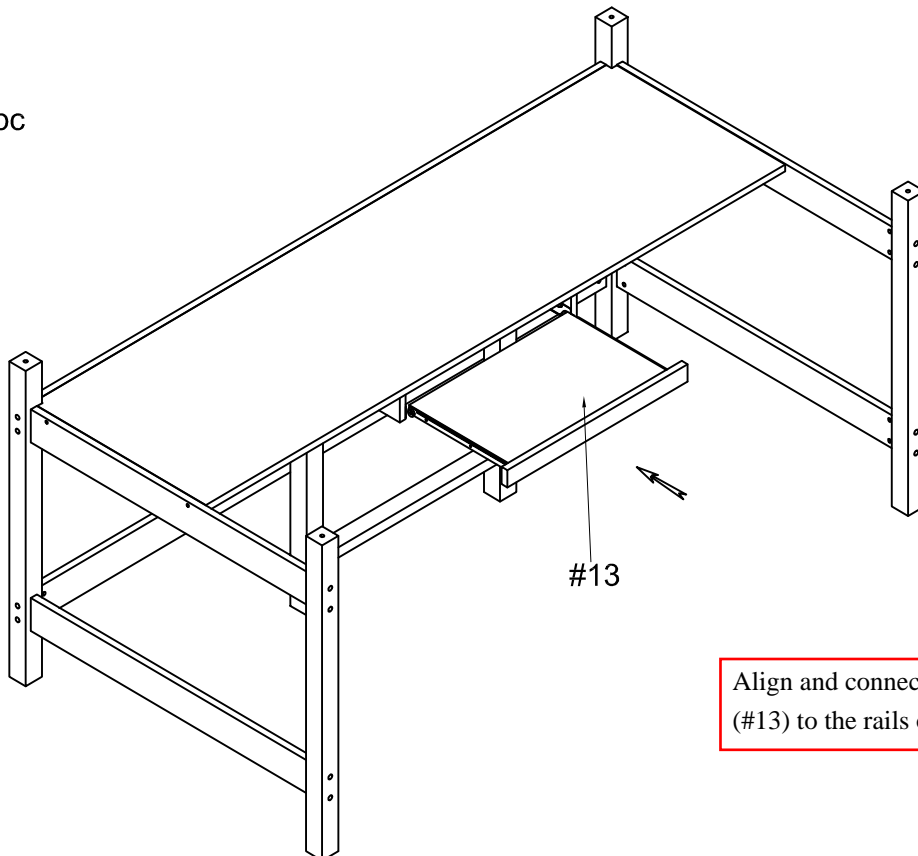

Align and connect keyboard shelf (#13) to the rails on the shelf panel.

ASSEMBLY INSTRUCTIONS

7

- Part #1 x1pc
- Part #2 x1pc
- Part #11 x1pc
- Part #17 x1pc
- Hardware #A x10 pcs
- Hardware #B x10 pcs
- Hardware #C x8 pcs

Insert dowels (#C) to rails (#11,17).
Align rails (#11,17) to headboards (#1,2),
then secure by using bolts (#A) onto
barrel nuts (#B).

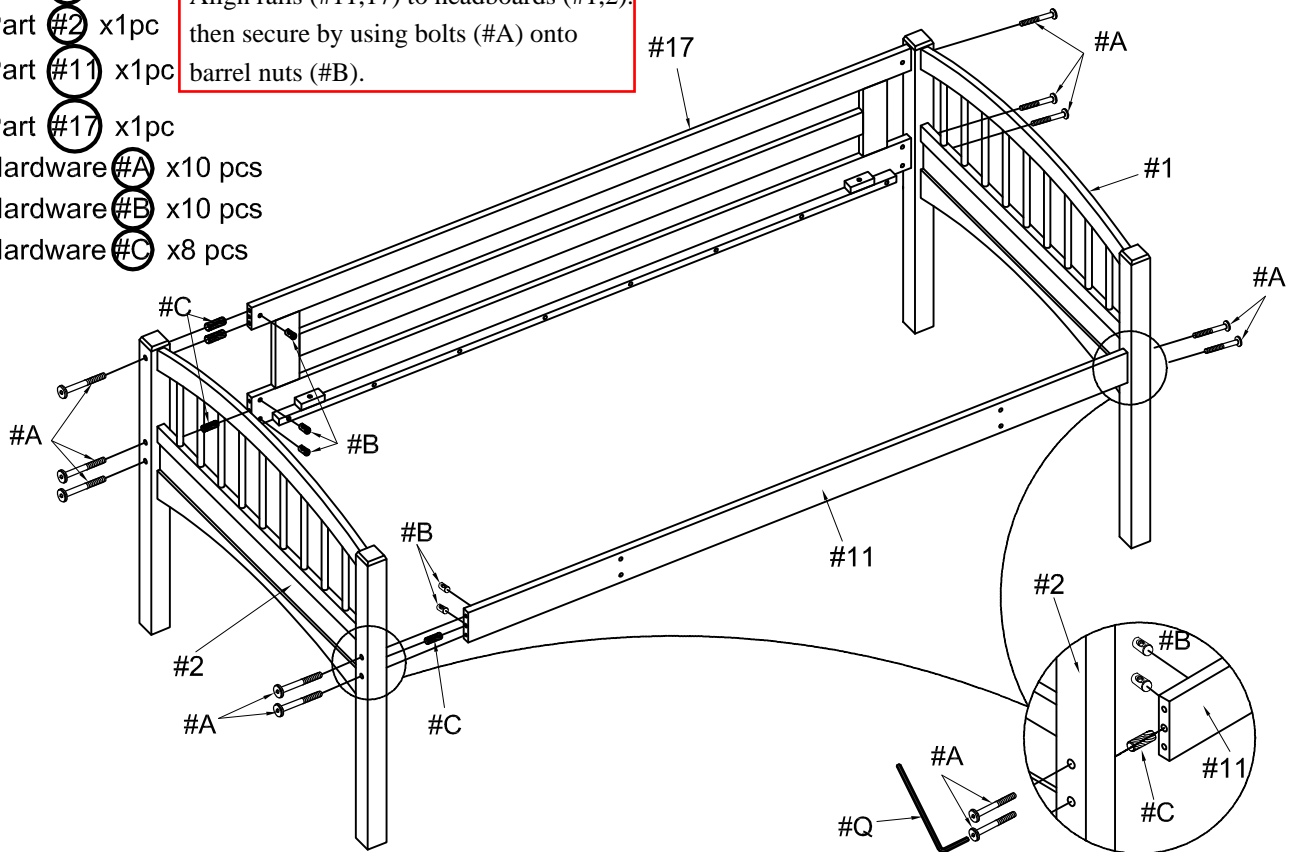

8

- Hardware #H x6 pcs

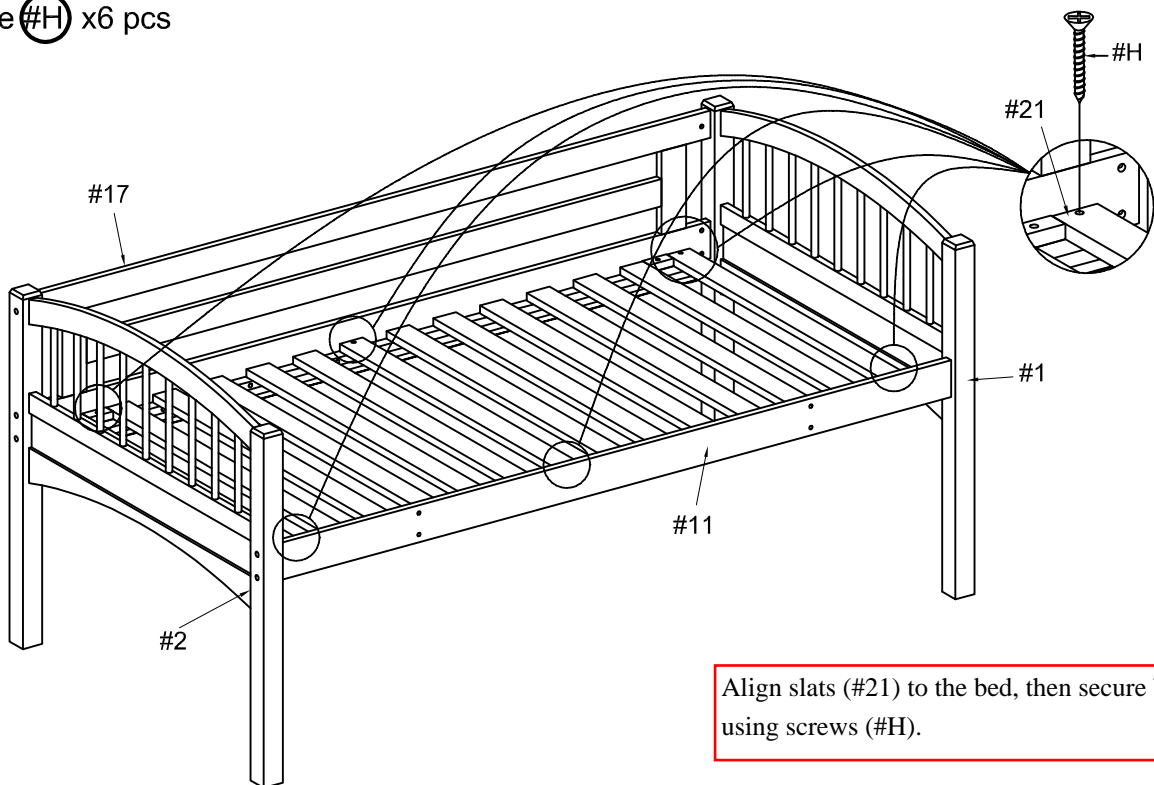

Align slats (#21) to the bed, then secure by
using screws (#H).

ASSEMBLY INSTRUCTIONS

9

Part #16 x1pc
Hardware #F x 4 pcs

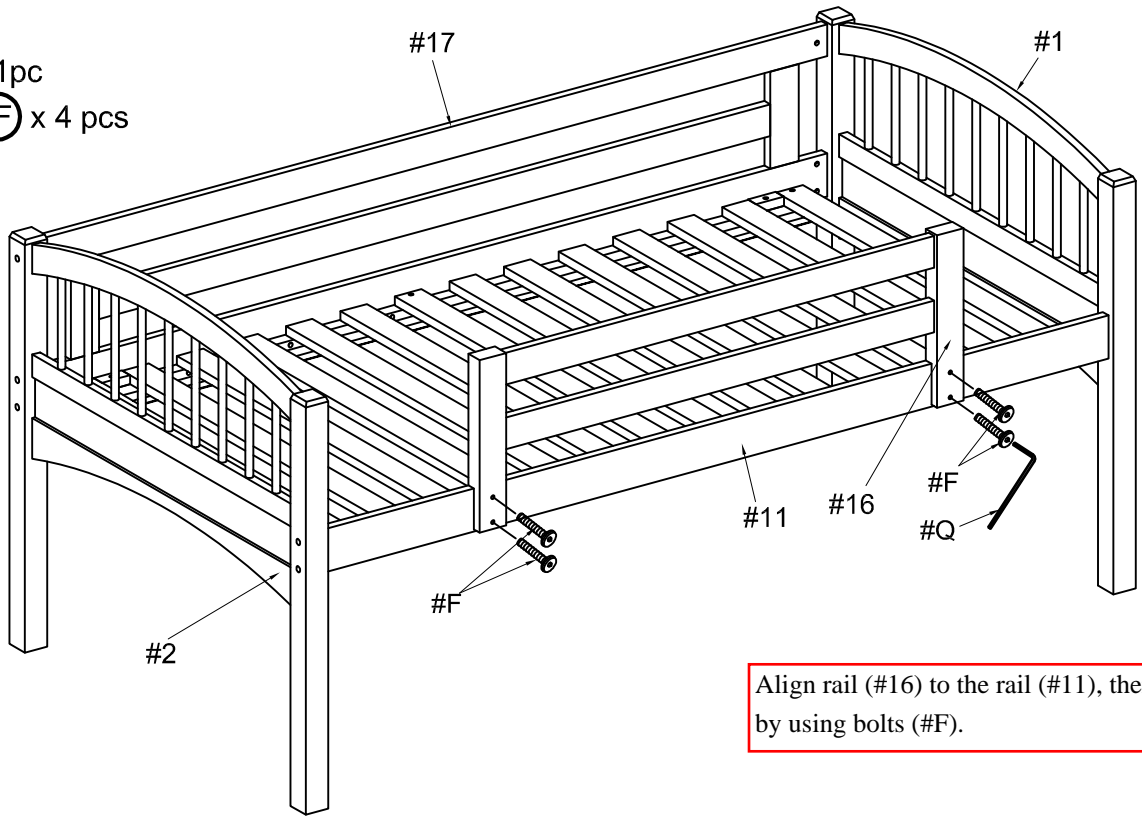

Align rail (#16) to the rail (#11), then secure by using bolts (#F).

10

Hardware #N x4 pcs

Insert dowels (#N) to the bottom unit, then align the top unit to bottom unit.

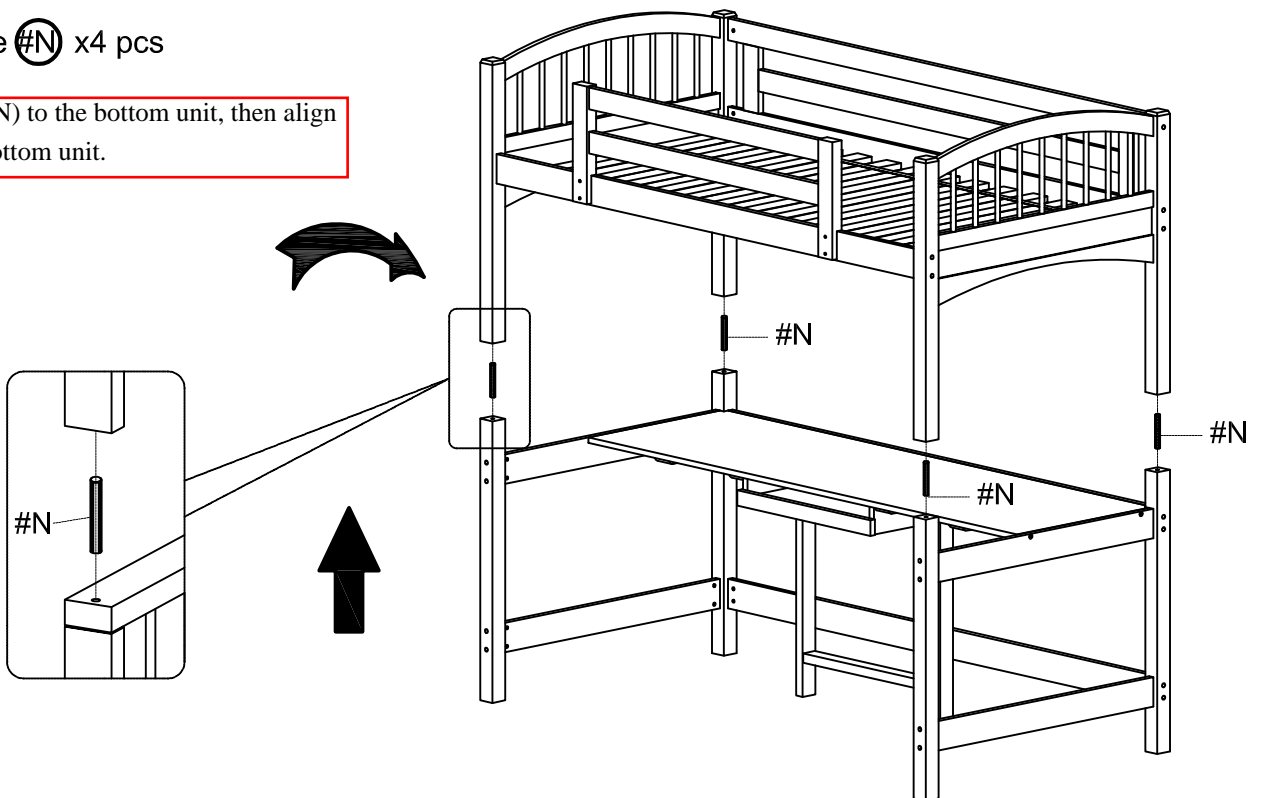

ASSEMBLY INSTRUCTIONS

11

- Part #18 x1pc
- Part #19 x1pc
- Part #20 x5pcs
- Hardware #P x10 pcs
- Hardware #C x20 pcs
- Hardware #K x2 pcs
- Hardware #K x4 pcs

Insert dowels (#C) to ladder rungs (#20), then align ladder rungs (#20) to ladder rails (#18,19). Secure by using screws (#P). Align brackets (#K) to the ladder rails (#18,19), then secure by using screws (#I).

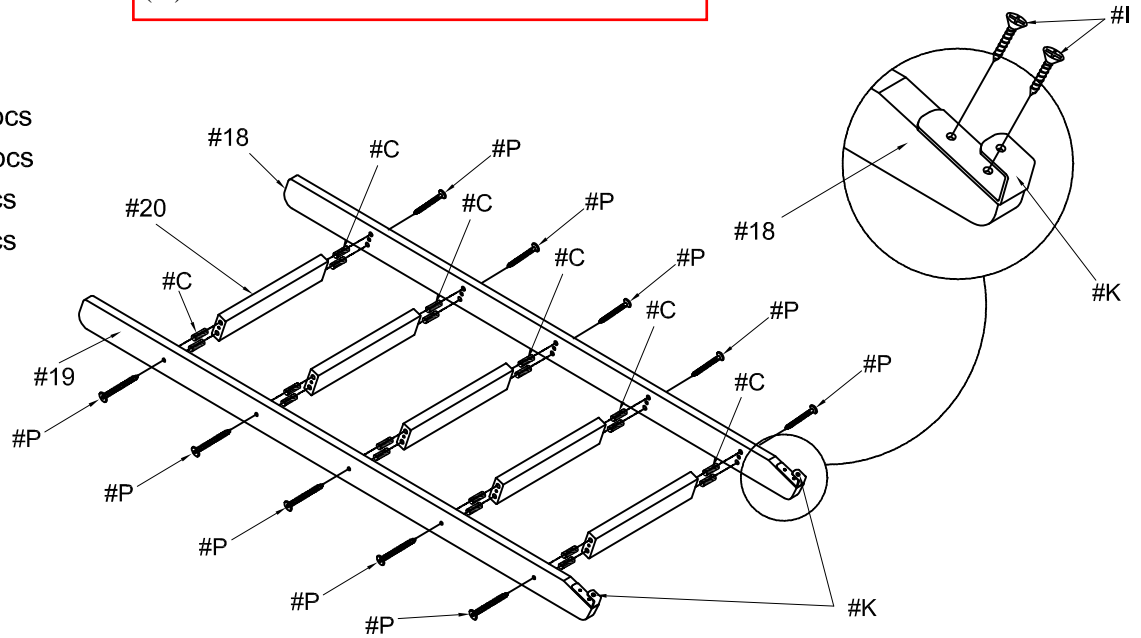

12

- Hardware #I x2 pcs

Align ladder to the bunk bed, then secure by using screws (#I).

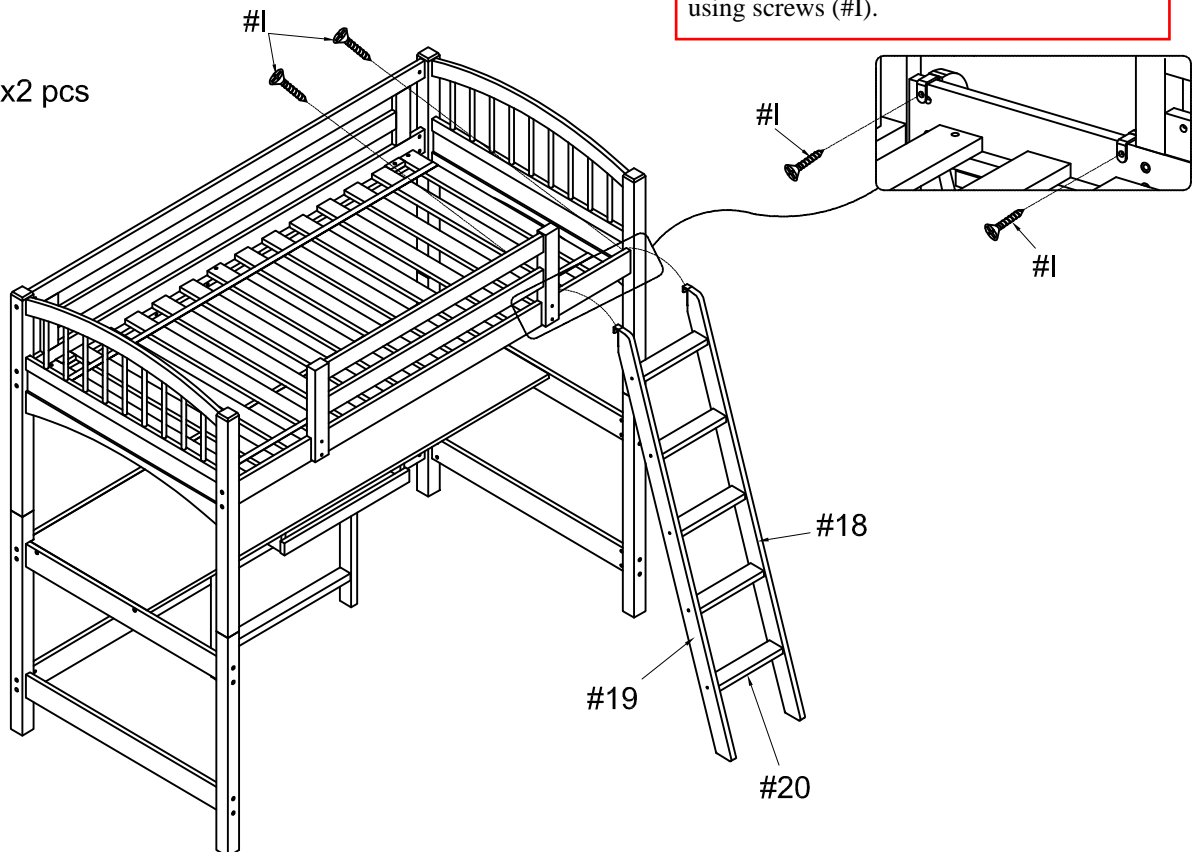

ASSEMBLY INSTRUCTIONS

13

- Part #22 x2pcs
- Part #23 x2pcs
- Part #24 x4pcs
- Part #27 x2pcs
- Hardware #J x24 pcs
- Hardware #F x16 pcs
- Hardware #D x8 pcs

Insert dowels (#D) to shelves (#24), then secure by using bolts (#F).

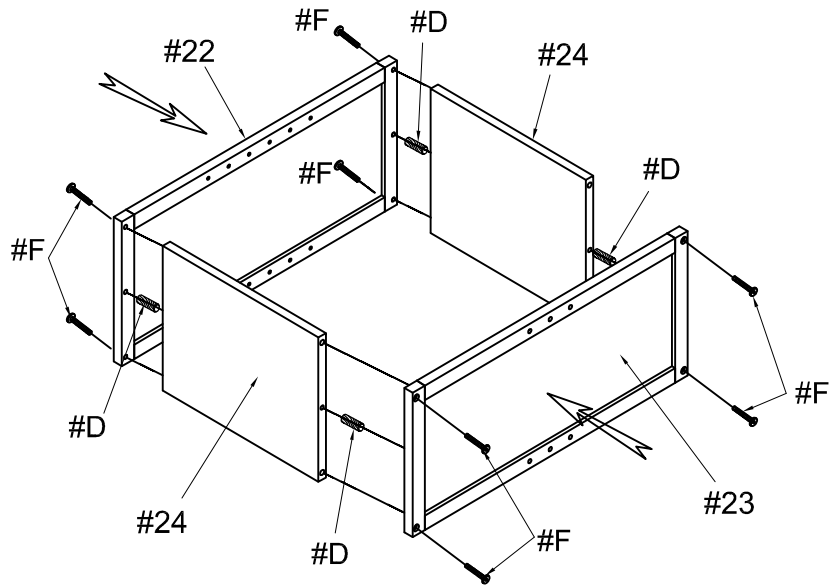

X 2

Align back (#27) to the unit, then secure by using screws (#J).

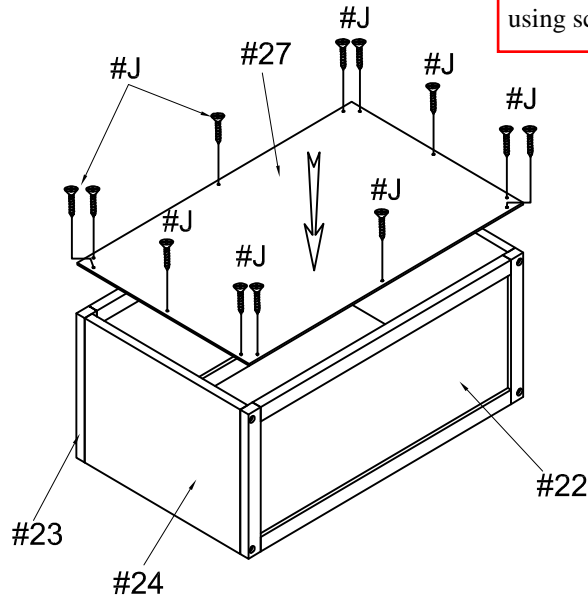

X 2

ASSEMBLY INSTRUCTIONS

Align shelf units to the table. Make sure the holes on the sides are facing each other.

14

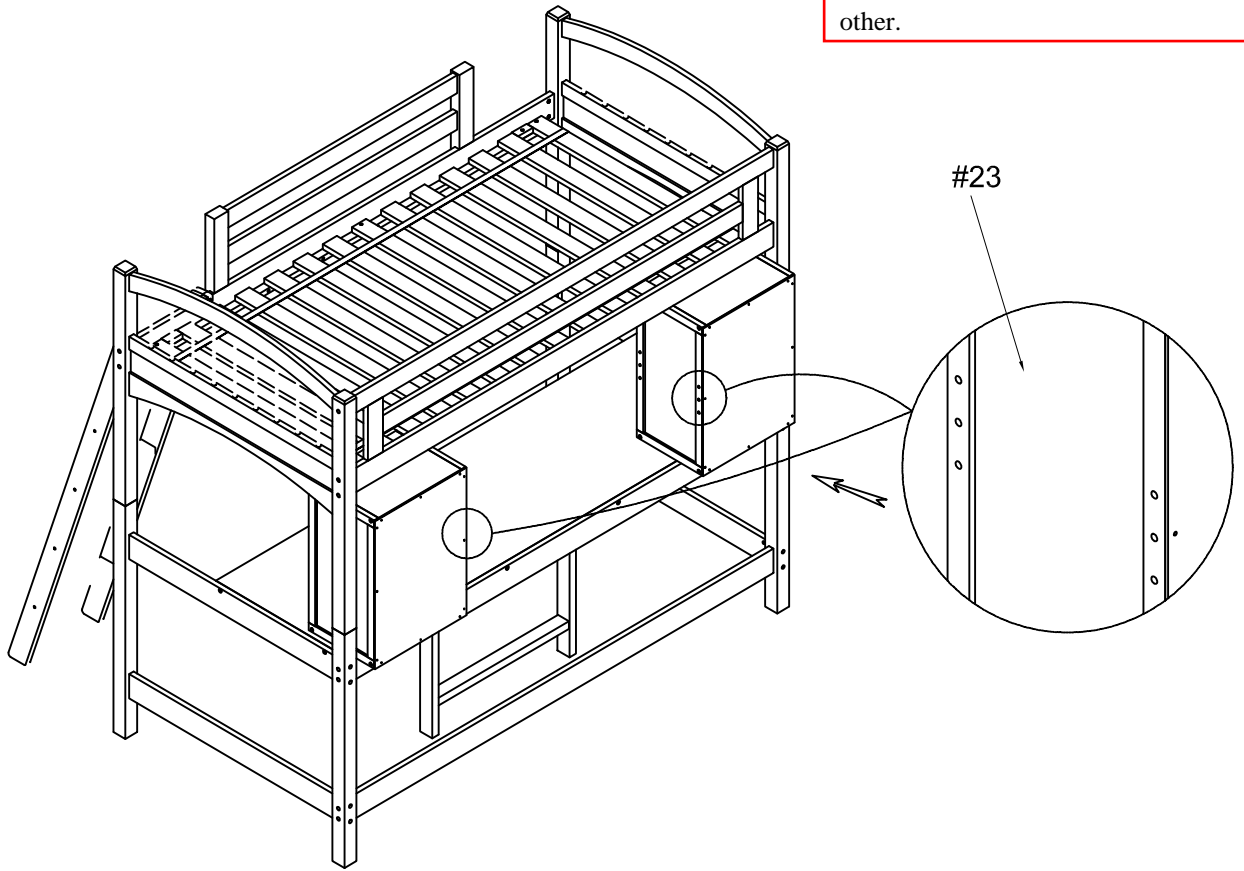

15

Part #26 x1pc
Hardware #F x4 pcs

Align long shelf (#26) to the shelf units, then secure by using bolts (#F).

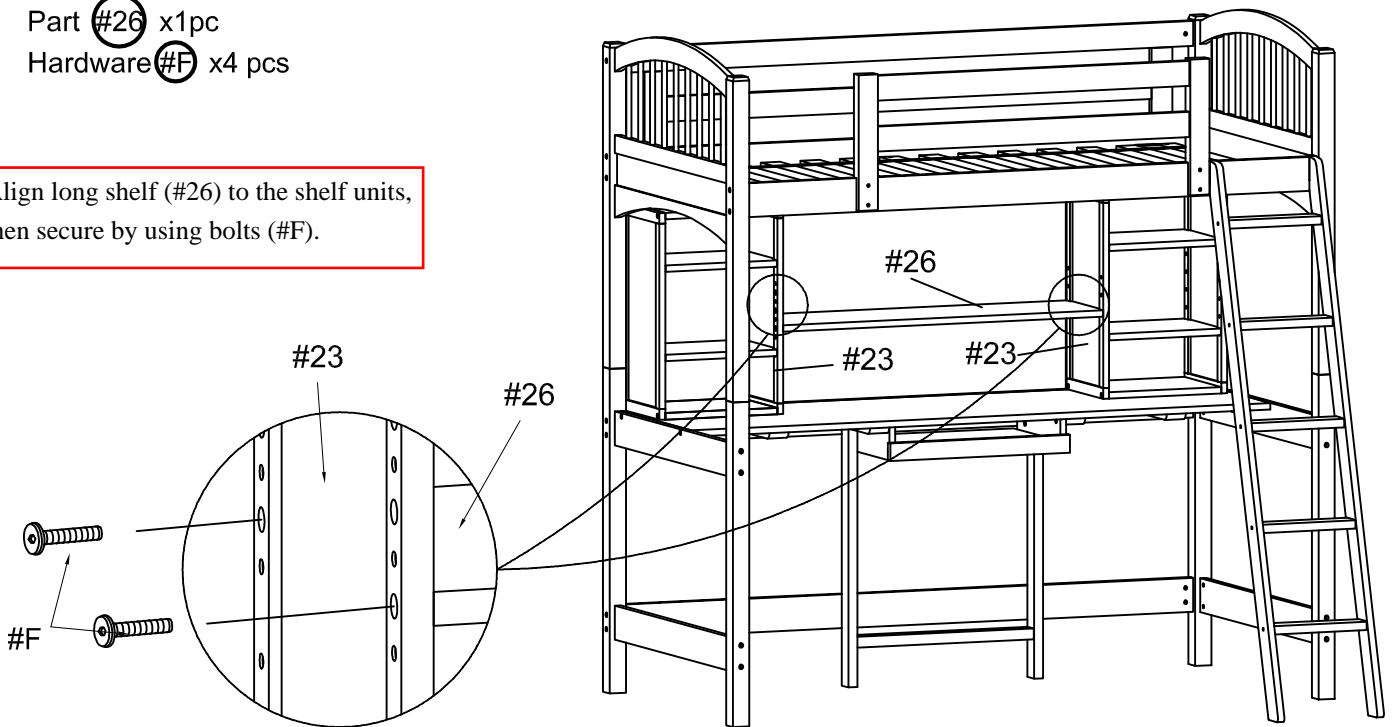

ASSEMBLY INSTRUCTIONS

16

Part #25 x4 pcs
Hardware #M x16 pcs

Insert shelf pins (#M) to the desired height of the shelves (#25).

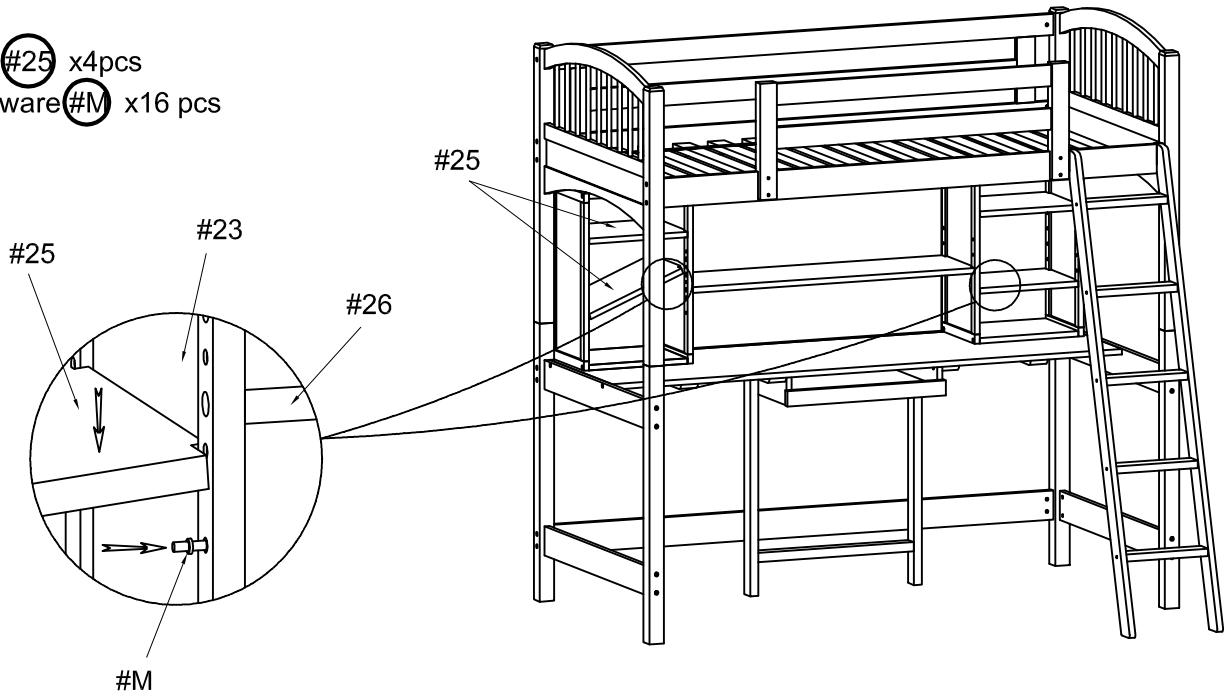

17

Hardware #I x8 pcs
Hardware #L x4 pcs
Hardware #O x34 pcs

Align brackets (#L) to the back of the shelf units, then secure by using screws (#I). Insert caps (#O) to holes of the bunk bed.

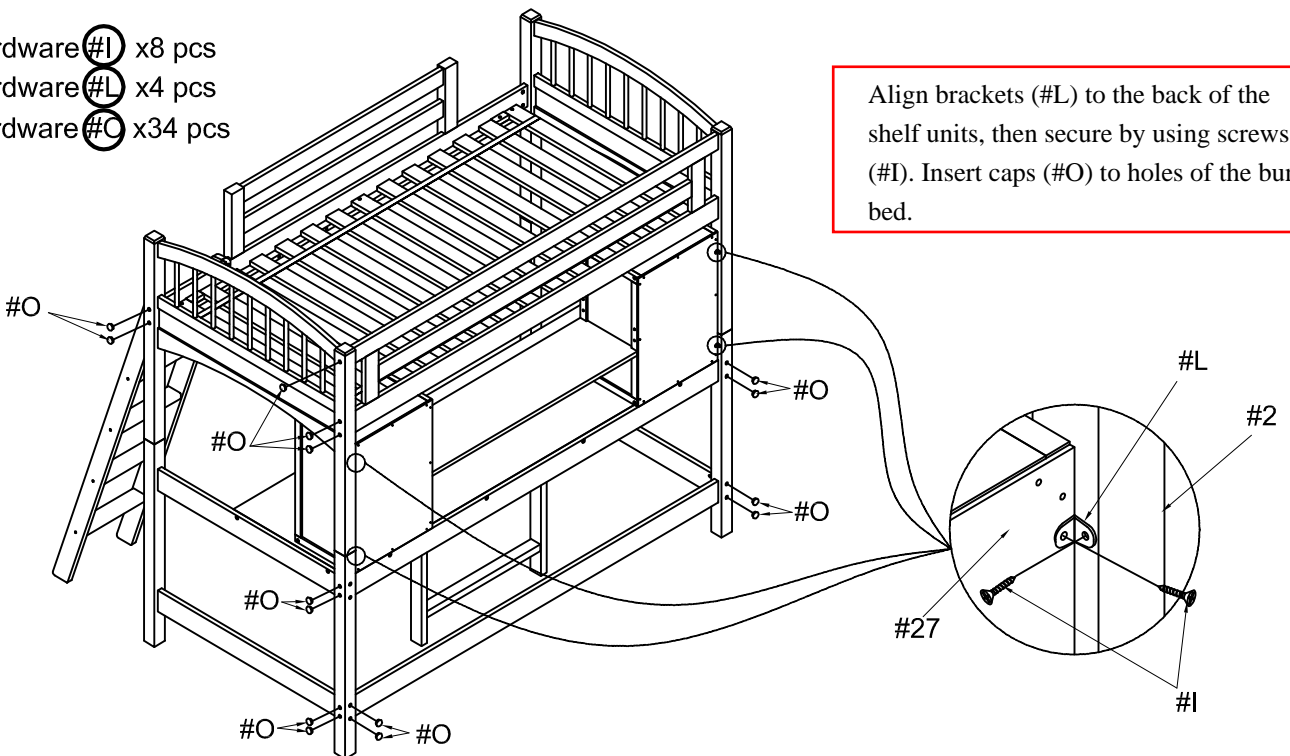

Safety Warnings for Bunk Beds

1. Read and follow the information on the WARNINGS shown on the end structure of the upper bunk and on the carton.
2. Do not remove warning label from the bed.
3. Keep these instructions for future reference.
4. **IMPORTANT: Must use Bunkie mattress or Bunkie board.** The proper sizes for the **UPPER/LOWER TWIN-SIZE** Bunkie mattress or Bunkie board should be 74" long and 37½" - 38½" wide with no more than 6" thickness and for the **UPPER/LOWER FULL-SIZE** should be 74" long and 53" - 54" wide with no more than 6" thickness.
5. Surface of mattress must be at least 5 inches (127 mm) **BELOW** the upper edge of guardrails.
6. The **MAXIMUM** weight capacity for the upper bunk is not to exceed 175 lbs.
7. Do not allow children under 6 years of age to use the upper bunk.
8. Periodically check and ensure that the guardrails, ladder, handle and other components are in their proper position, free from damage, and that all connectors are tightened and secured.
9. **DO NOT** allow horseplay, rough playing or jumping on the beds and do not allow playing or hiding under the beds.
10. Always use the ladder for entering or leaving the upper bunk.
11. Do not use substitute parts. Contact the manufacturer or dealer for replacement parts.
12. Use of a nightlight may provide added safety precaution for a person using the upper bunk.
13. Always use the guardrails on both sides of the upper bunk.
14. If the bunk bed will be placed next to a wall, the guardrail that runs the full length of the bed should be placed against the wall to prevent entrapment between the bed and the wall.
15. The use of water or sleep flotation mattresses is prohibited.
16. No more than one person is allowed on the upper bunk at all times.



WARNING: STRANGULATION HAZARD

Never attach or hang objects to any part of the bunk bed that are not designed for use with the bed. Objects such as hanger, hook, belt, bag, rope, string, etc. should not be used on or around the bunk bed.