

# ASSEMBLY INSTRUCTIONS

# EEI-6278

V0.02.02.23

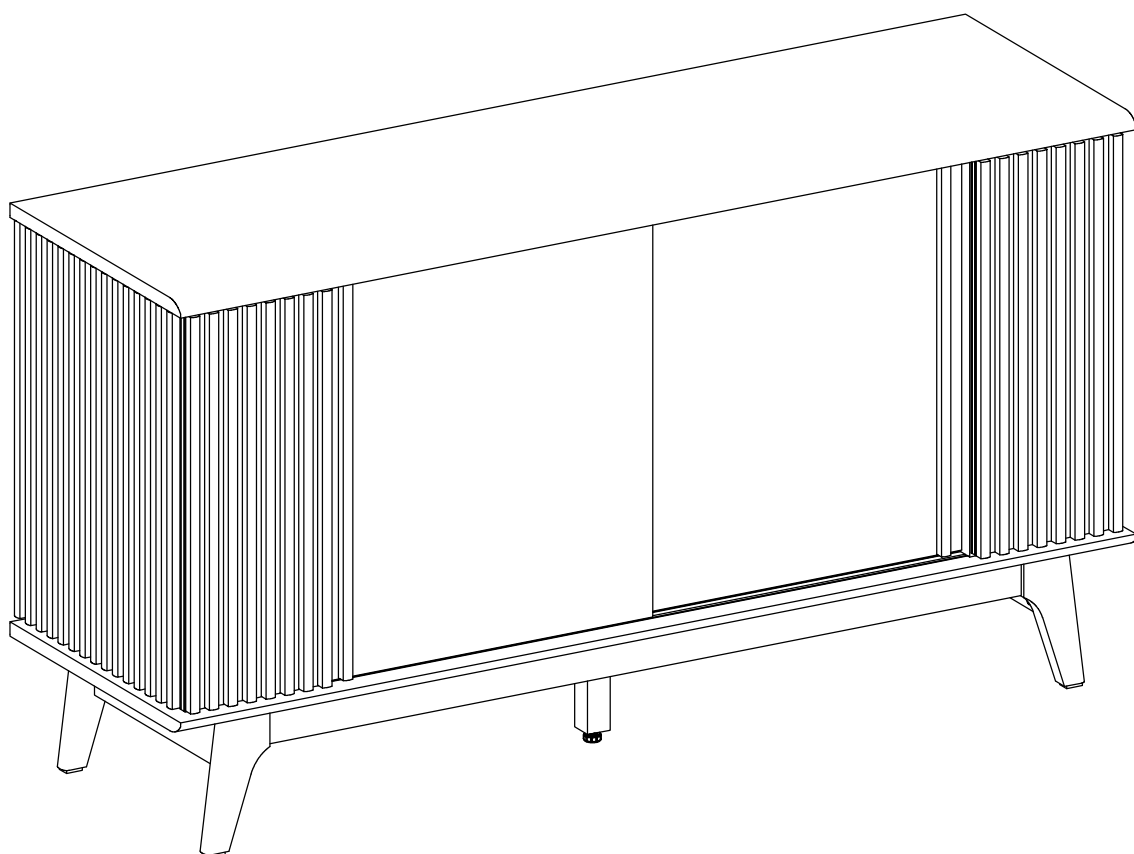

**Questions? Contact us!**

609.256.9000 • [cs@modway.com](mailto:cs@modway.com)  
[www.modway.com](http://www.modway.com)

**\*modway**

# Let's get started!

\*modway



Read through all of the instructions before starting



Care instructions are listed in the last step of this manual



Approx. 60 minutes assembly time



Make sure you have all parts and components before discarding any packing materials



2 people recommended for assembly

**Only use hand tools to assemble this item.** Do not use power tools. Do not tighten bolts or screws completely until all hardware is lined up and inserted into the holes.

Do not over-tighten screws and bolts to avoid stripping the hardware or cracking the item.

Assemble your item on a flat, carpeted area, with plenty of space to work. This will prevent damage and scratches to your floors or the item while you're assembling the product.

Keep all components and packaging out of reach of children or animals to avoid risk of choking or suffocation.

## Furniture components:

1	Top Board	x1	13	Backboard	x2
2	Bottom Board	x1	14	Front Bottom Support	x2
3	Left Side Board	x1	15	Side Bottom Support	x2
4	Right Side Board	x1	16	Middle Bottom Support	x2
5	Divider Board	x1	17	Left Leg	x2
6	Back Left Shelf Support	x1	18	Right Leg	x2
7	Back Right Shelf Support	x1	19	Middle Leg	x1
8	Adjustable Shelf	x4	20	Left Side Door Support	x1
9	Front Left Shelf Support	x2	21	Right Side Door Support	x1
10	Side Left Shelf Support	x2	22	Side Door	x2
11	Left Shelf Board	x2	23	Door	x2
12	Right Shelf Board	x2	24	Side Right Shelf Support	x2
25	Front Right Shelf Support	x2			

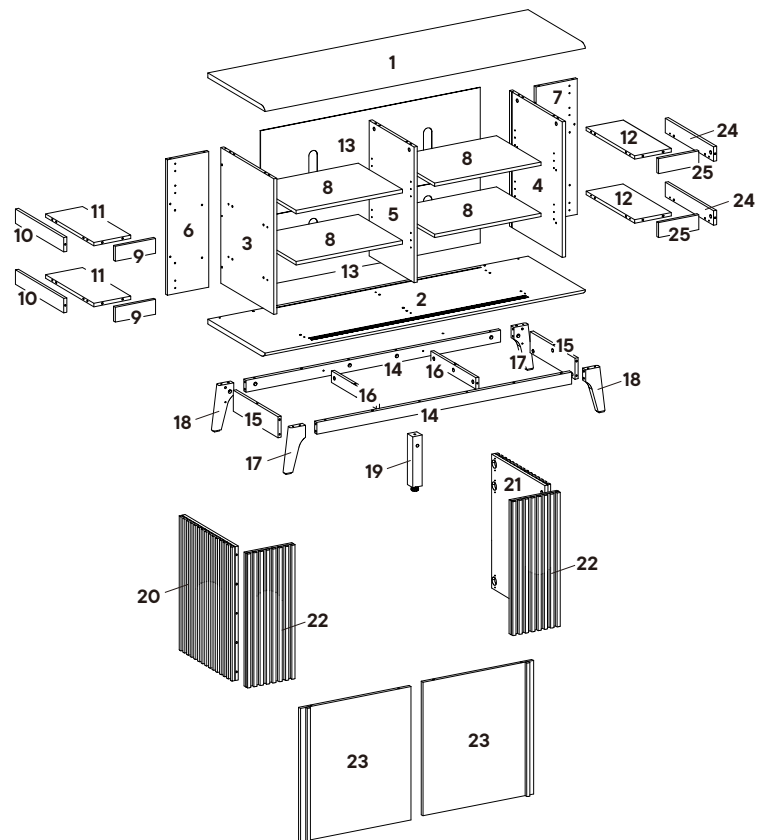









Wait!







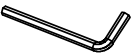



**Missing parts or hardware? Need assistance?**

Contact us before returning your item. We're here to help!

609.256.9000 • cs@modway.com

## Provided hardware:

A		Cam Lock Ø15 mm	x56
B		Cam Bolt Ø7.5 x 32 mm	x52
C		Cam Cover Ø17 mm	x56
D		Plastic Dowel Ø8 x 32 mm	x64
E		Door Hinge	x6
F		Cam Bolt Ø7 x 42 mm	x4
G		Screw M 10 x 33.5 mm	x28
H		Screw M 6 x 60 mm	x1
I		Allen Key	x1
J		H-Profile	x1
K		Shelf Pin Ø7 x 16.5 mm	x16

L		Screw M 3 x 12 mm	x4
M		Screw M 4 x 19 mm	x16
N		Backply Stopper	x16
O		Top Door Pin	x4
P		Bottom Door Pin	x4
Q		Buffer	x8
R		Screw M 4 x 10 mm	x24
S		Corner Bracket	x4
T		Barrel Nut	x1
U		Washer Plate Ø13 mm	x4
V		Wall Bracket Set	x1

## What you need:

  Phillips Head Screwdriver

**Wait!**

**Missing parts or hardware? Need assistance?**

Contact us before returning your item. We're here to help!

609.256.9000 • [cs@modway.com](mailto:cs@modway.com)

# Step 1

## HARDWARE

- B** Cam Bolt  $\varnothing 7.5 \times 32$  mm x20
- F** Cam Bolt  $\varnothing 7 \times 42$  mm x4

## COMPONENTS

- 3** Top Board x1
- 4** Bottom Board x1

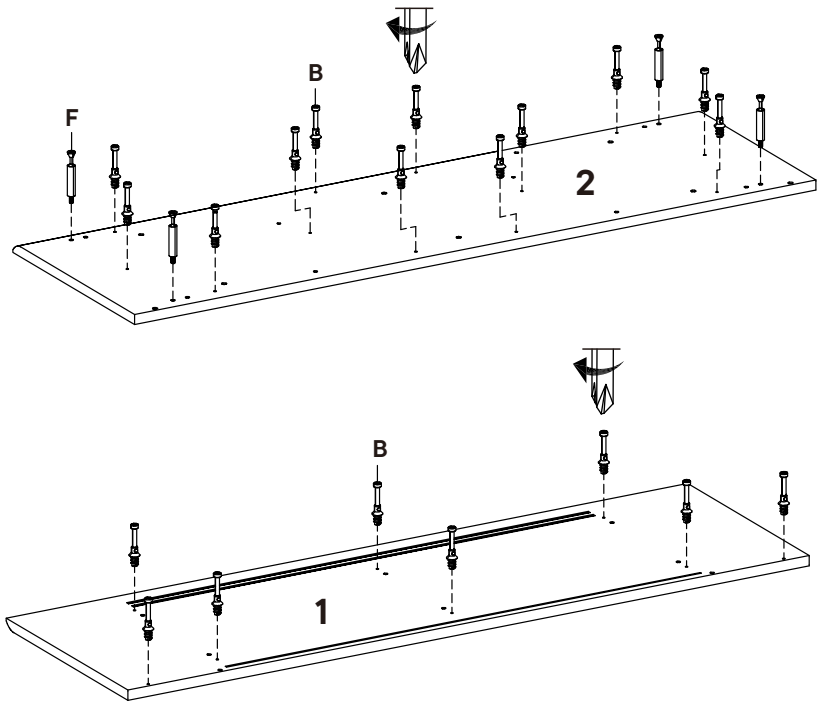

# Step 2

## HARDWARE

- B** Cam Bolt  $\varnothing 7.5 \times 32$  mm x2
- D** Plastic Dowel  $\varnothing 8 \times 32$  mm x8

## COMPONENTS

- 3** Left Side Board x1
- 4** Right Side Board x1

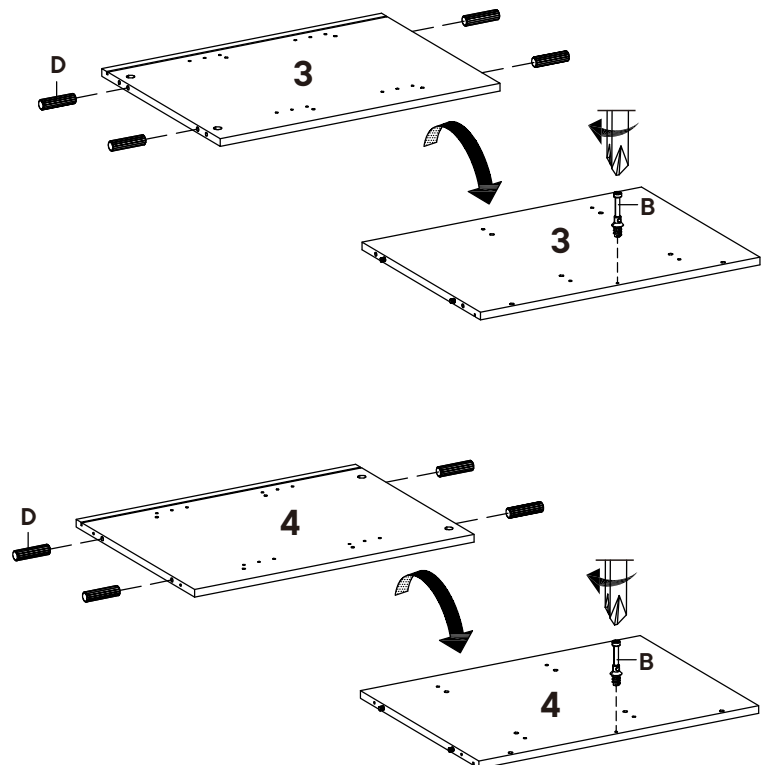

# Step 3

## HARDWARE

**D** Plastic Dowel Ø8 x 32 mm x12

## COMPONENTS

**5** Divider Board x1

**6** Back Left Shelf Support x1

**7** Back Right Shelf Support x1

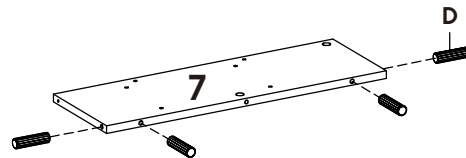
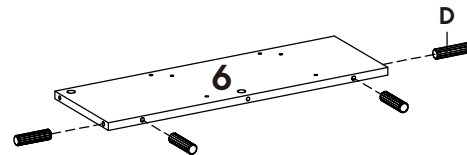
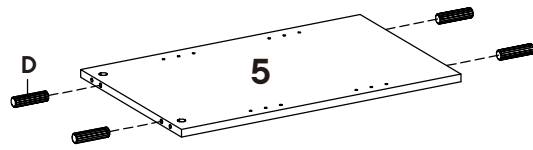

# Step 4

## HARDWARE

**B** Cam Bolt Ø7.5 x 32 mm x16

**D** Plastic Dowel Ø8 x 32 mm x20

## COMPONENTS

**9** Front Left Shelf Support x2

**10** Side Left Shelf Support x2

**11** Left Shelf Board x2

**12** Right Shelf Board x2

**24** Side Right Shelf Support x2

**25** Front Right Shelf Support x2

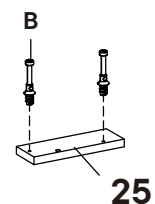
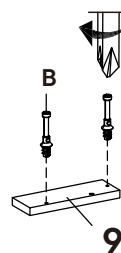
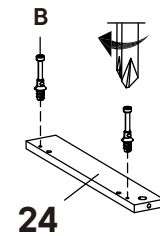
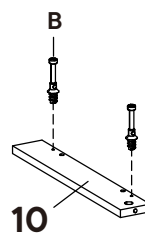
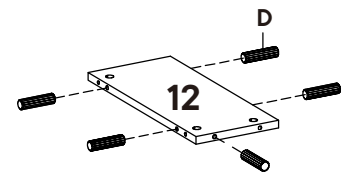
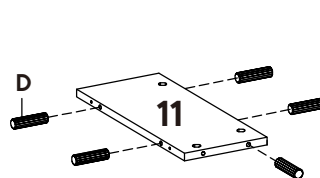

# Step 5

## HARDWARE

- B** Cam Bolt Ø7.5 x 32 mm x8
- D** Plastic Dowel Ø8 x 32 mm x20
- T** Barrel Nut x1

## COMPONENTS

- 14** Front Bottom Support x2
- 15** Side Bottom Support x2
- 17** Left Leg x2
- 18** Right Leg x2
- 19** Middle Leg x1

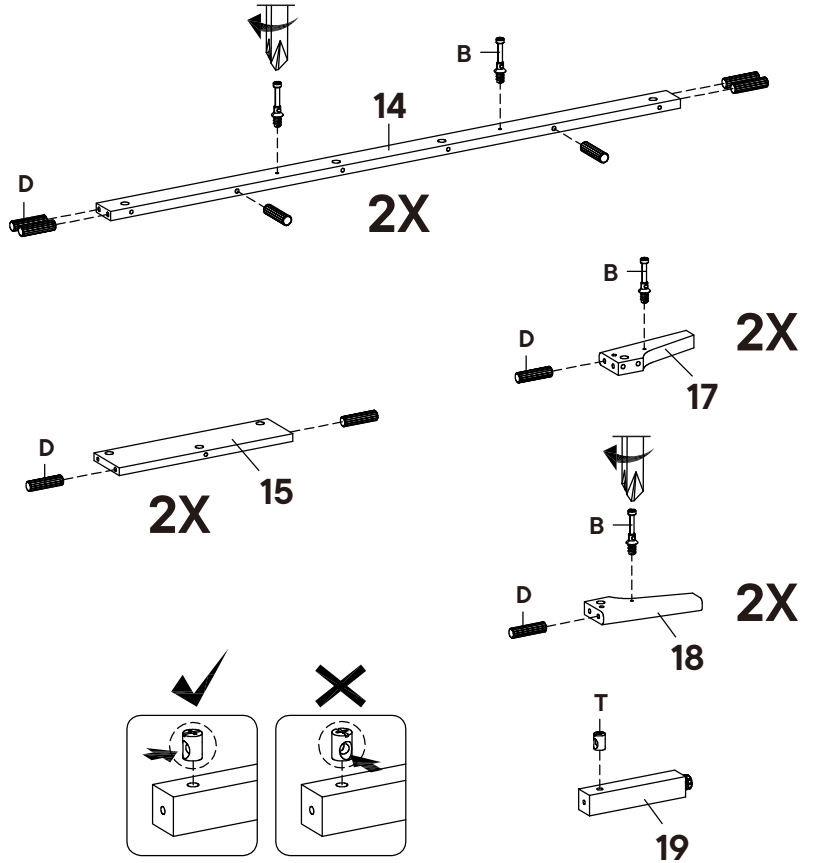

# Step 6

## HARDWARE

- A** Cam Lock Ø15 mm x8
- C** Cam Cover Ø17 mm x8

## COMPONENTS

- 9** Front Left Shelf Support x2
- 10** Side Left Shelf Support x2
- 11** Left Shelf Board x2

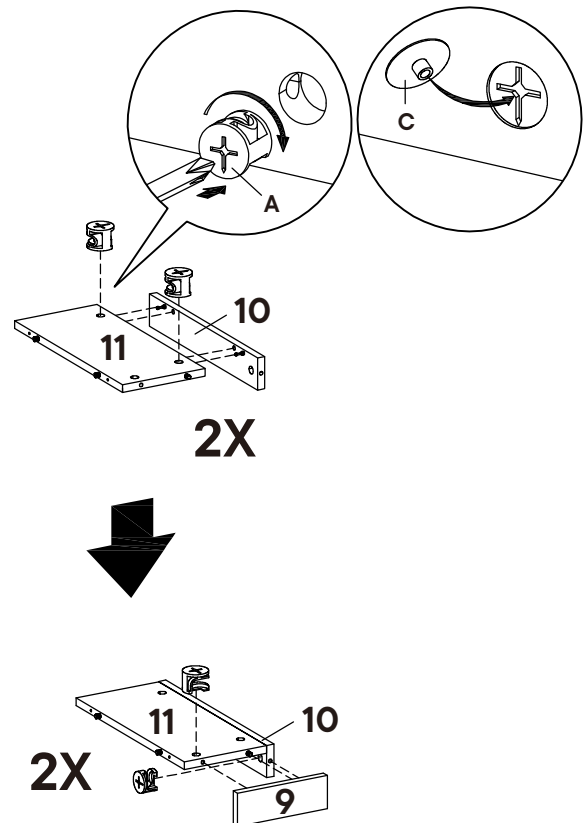

# Step 7

## HARDWARE

- A** Cam Lock Ø15 mm x8
- C** Cam Cover Ø17 mm x8

## COMPONENTS

- 12** Right Shelf Board x1
- 24** Side Right Shelf Support x1
- 25** Front Right Shelf Support x1

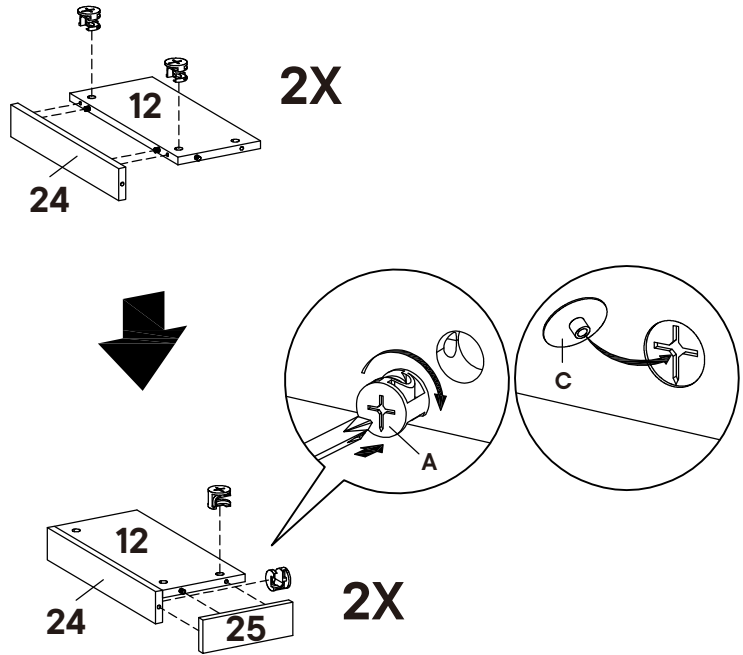

# Step 8

## HARDWARE

- G** Screw M 10 x 33.5 mm x8

## COMPONENTS

- 3** Left Side Board x1
- 4** Right Side Board x1
- 11** Left Shelf Board x2
- 12** Right Shelf Board x2

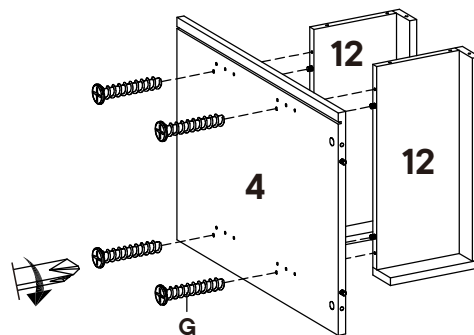
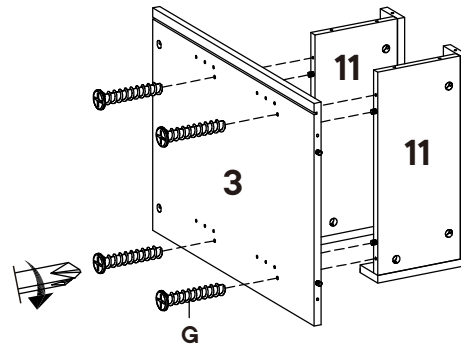

## Step 9

### HARDWARE

- A** Cam Lock Ø15 mm x2
- C** Cam Cover Ø17 mm x2

### COMPONENTS

- 3** Left Side Board x1
- 4** Right Side Board x1
- 6** Back Left Shelf Support x1
- 7** Back Right Shelf Support x1

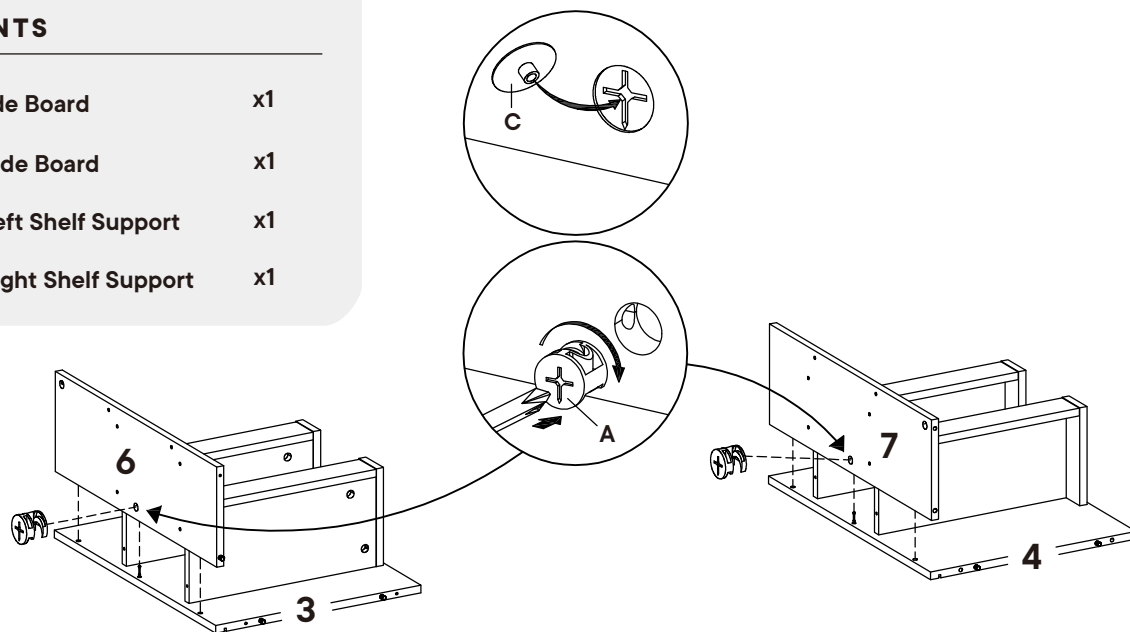

## Step 10

### HARDWARE

- G** Screw M 10 x 33.5 mm x12

### COMPONENTS

- 6** Back Left Shelf Support x1
- 7** Back Right Shelf Support x1
- 11** Left Shelf Board x1
- 12** Right Shelf Board x1

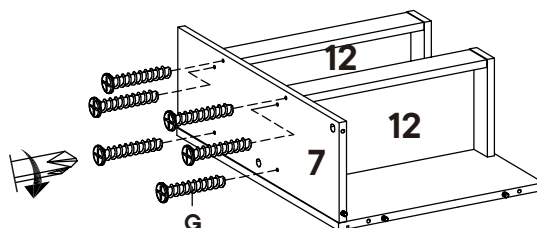
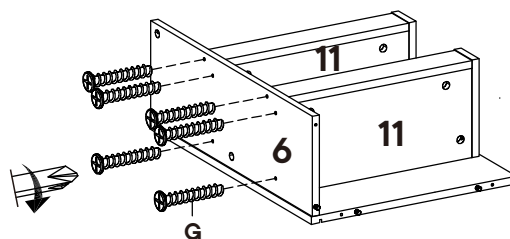



# Step 11

## HARDWARE

- A** Cam Lock  $\varnothing$ 15 mm x4
- C** Cam Cover  $\varnothing$ 17 mm x4

## COMPONENTS

- 14** Front Bottom Support x2
- 16** Middle Bottom Support x2

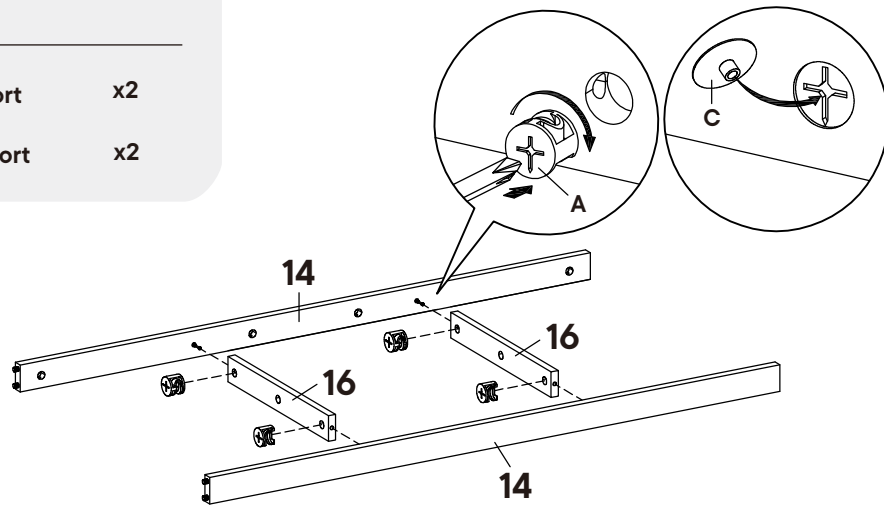

# Step 12

## HARDWARE

- A** Cam Lock  $\varnothing$ 15 mm x4
- C** Cam Cover  $\varnothing$ 17 mm x4

## COMPONENTS

- 15** Side Bottom Support x2
- 17** Left Leg x2
- 18** Right Leg x2

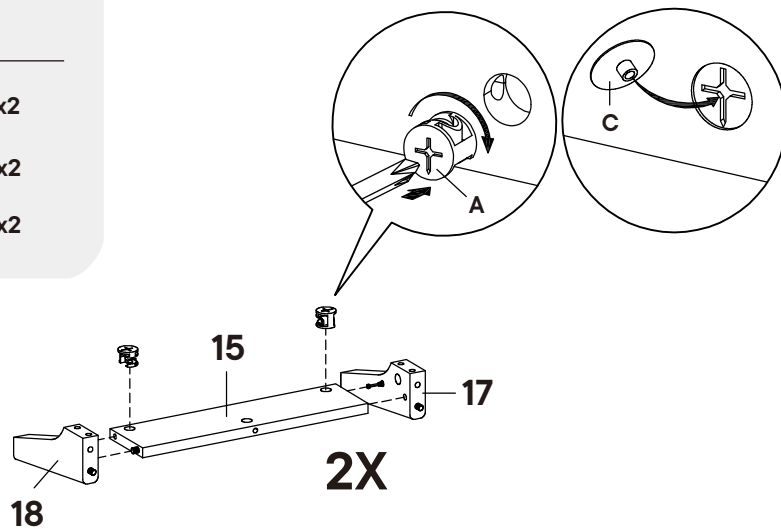

## Step 13

### COMPONENTS

- |    |                      |    |
|----|----------------------|----|
| 14 | Front Bottom Support | x2 |
| 17 | Left Leg             | x2 |
| 18 | Right Leg            | x2 |

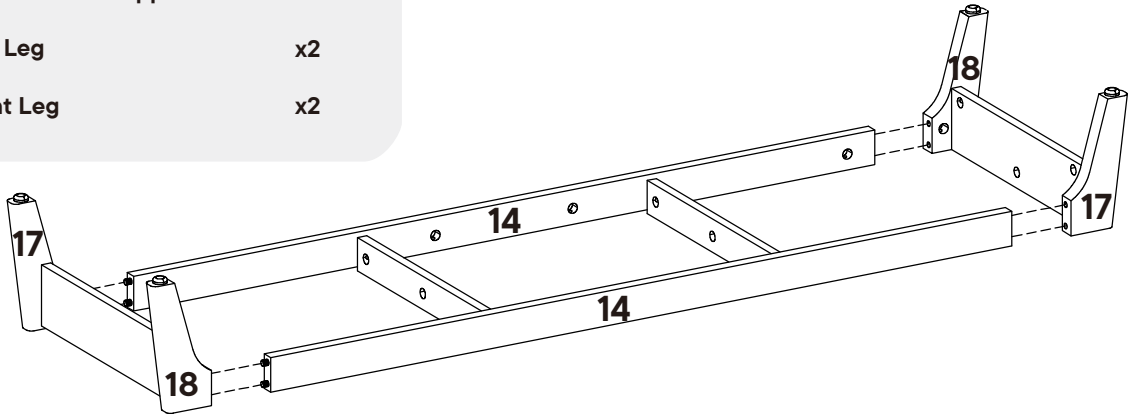

## Step 14

### HARDWARE

- |   |                  |     |
|---|------------------|-----|
| A | Cam Lock Ø15 mm  | x16 |
| C | Cam Cover Ø17 mm | x16 |

### COMPONENTS

- |    |                       |    |
|----|-----------------------|----|
| 2  | Bottom Board          | x1 |
| 14 | Front Bottom Support  | x2 |
| 15 | Side Bottom Support   | x2 |
| 16 | Middle Bottom Support | x2 |
| 17 | Left Leg              | x2 |
| 18 | Right Leg             | x2 |

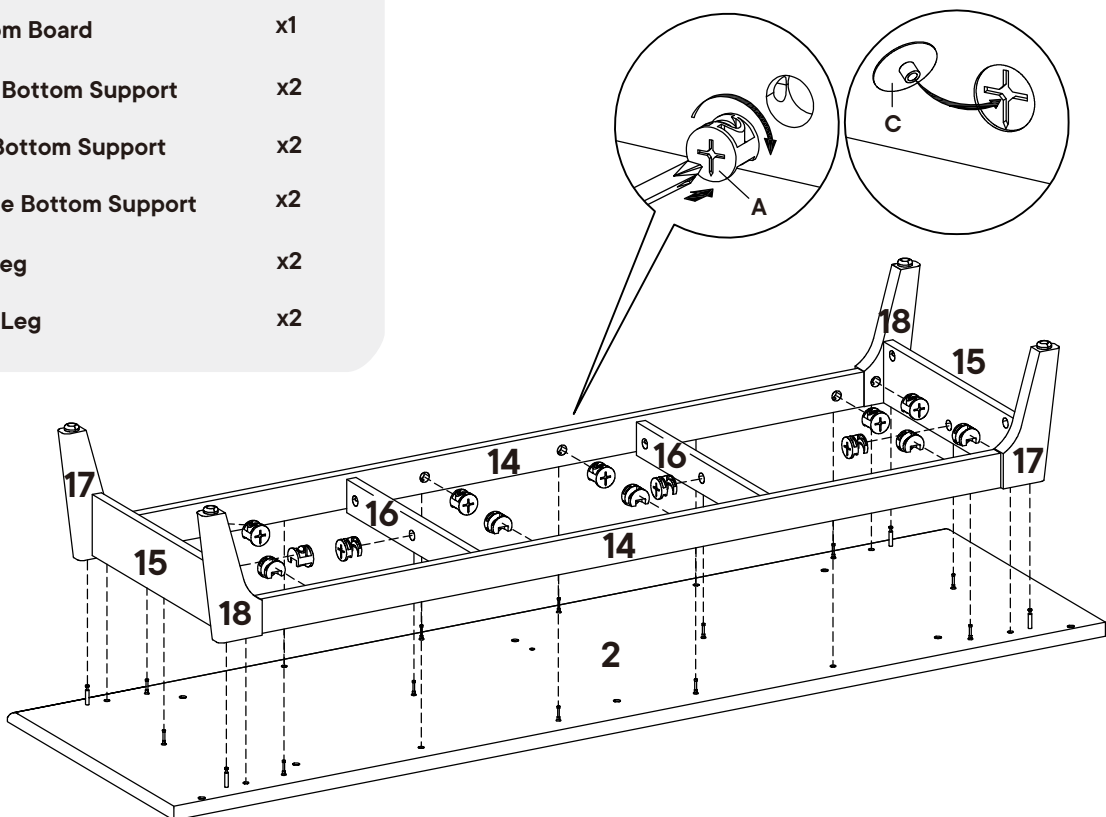

## Step 15

### HARDWARE

- H** Screw M 6 x 60 mm x1
- I** Allen Key x1

### COMPONENTS

- 2** Bottom Board x1
- 19** Middle Leg x1

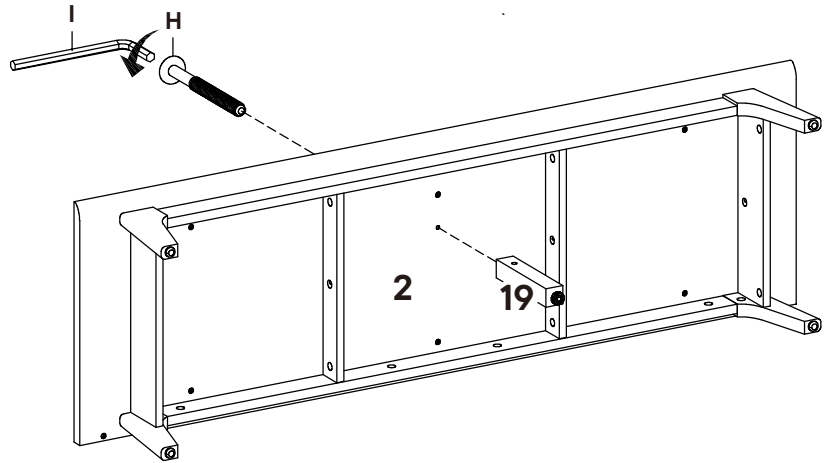

## Step 16

### HARDWARE

- G** Screw M 10 x 33.5 mm x6

### COMPONENTS

- 2** Bottom Board x1
- 3** Left Side Board x1
- 4** Right Side Board x1
- 6** Back Left Shelf Support x1
- 7** Back Right Shelf Support x1

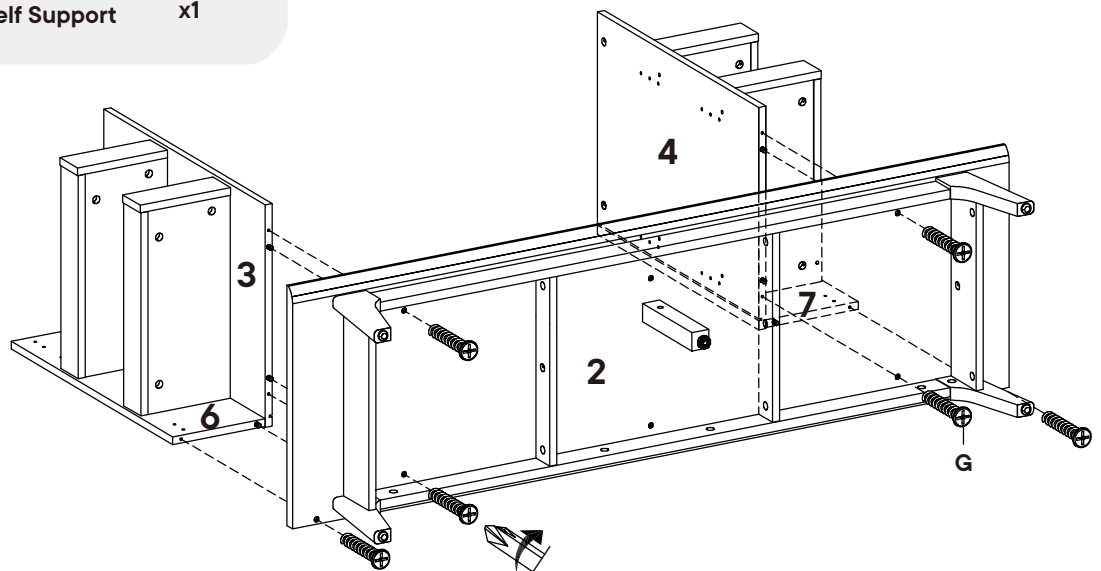

## Step 17

### HARDWARE

- G** Screw M 10 x 33.5 mm x2

### COMPONENTS

- 2** Bottom Board x1  
**5** Divider Board x1

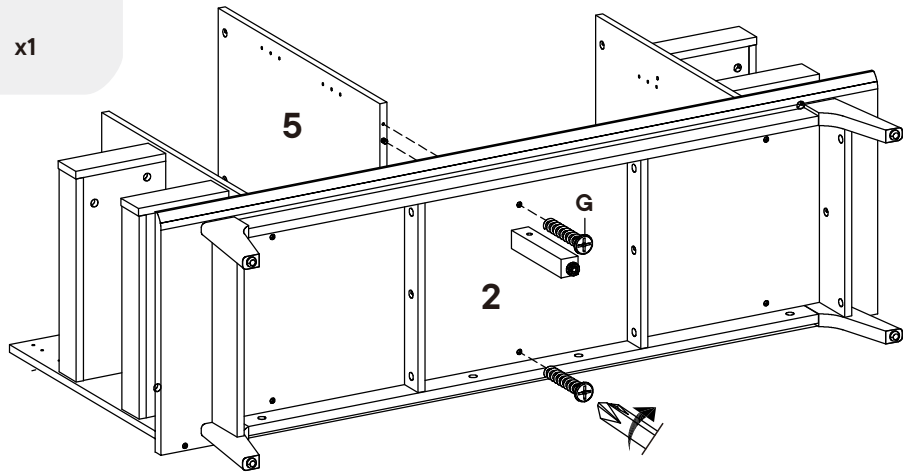

## Step 18

### HARDWARE

- J** H-Profile x1

### COMPONENTS

- 2** Bottom Board x1  
**3** Left Side Board x1  
**4** Right Side Board x1  
**13** Backboard x2

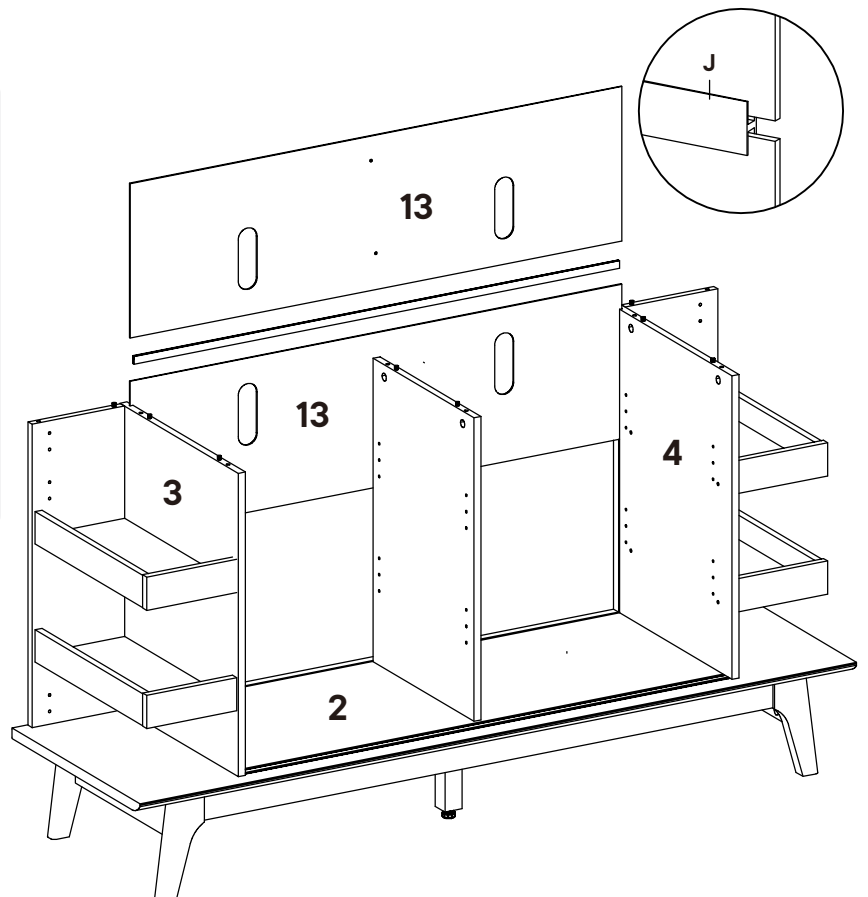

# Step 19

## HARDWARE

- |          |                               |    |
|----------|-------------------------------|----|
| <b>A</b> | Cam Lock $\varnothing$ 15 mm  | x8 |
| <b>C</b> | Cam Cover $\varnothing$ 17 mm | x8 |

## COMPONENTS

- |          |                          |    |
|----------|--------------------------|----|
| <b>1</b> | Top Board                | x1 |
| <b>3</b> | Left Side Board          | x1 |
| <b>4</b> | Right Side Board         | x1 |
| <b>5</b> | Divider Board            | x1 |
| <b>6</b> | Back Left Shelf Support  | x1 |
| <b>7</b> | Back Right Shelf Support | x1 |

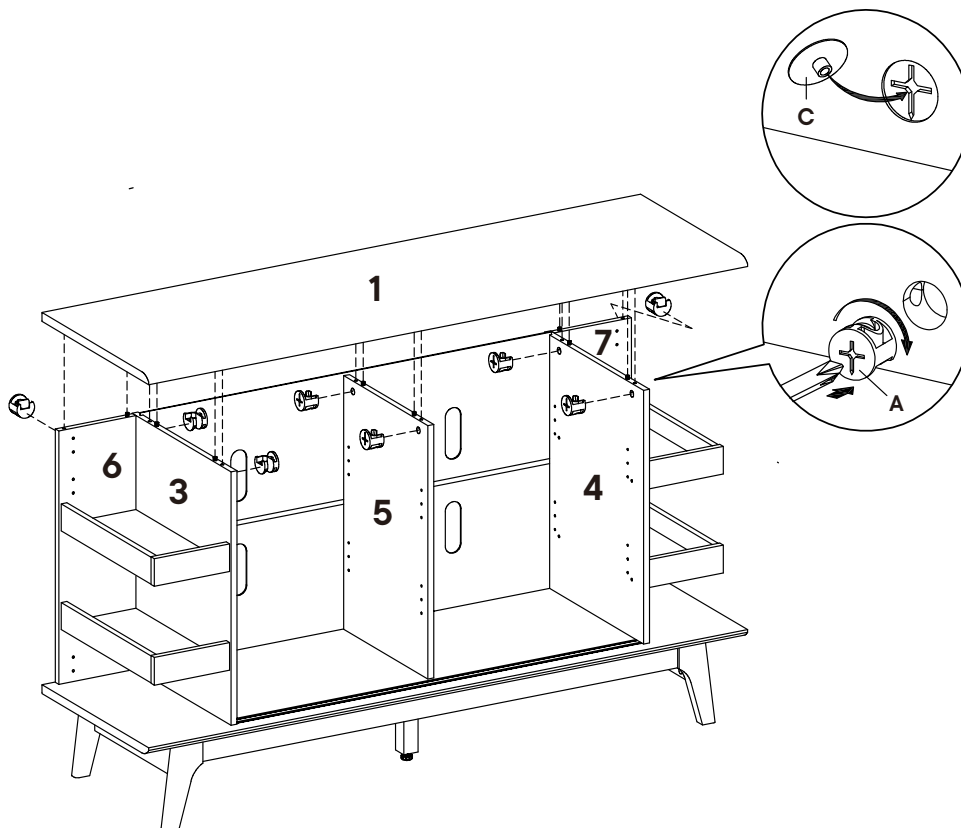

# Step 20

## HARDWARE

<b>L</b>	Screw M 3 x 12 mm	x4
<b>M</b>	Screw M 4 x 19 mm	x16
<b>N</b>	Backply Stopper	x16

## COMPONENTS

<b>1</b>	Top Board	x1
<b>2</b>	Bottom Board	x1
<b>3</b>	Left Side Board	x1
<b>4</b>	Right Side Board	x1
<b>13</b>	Backboard	x2

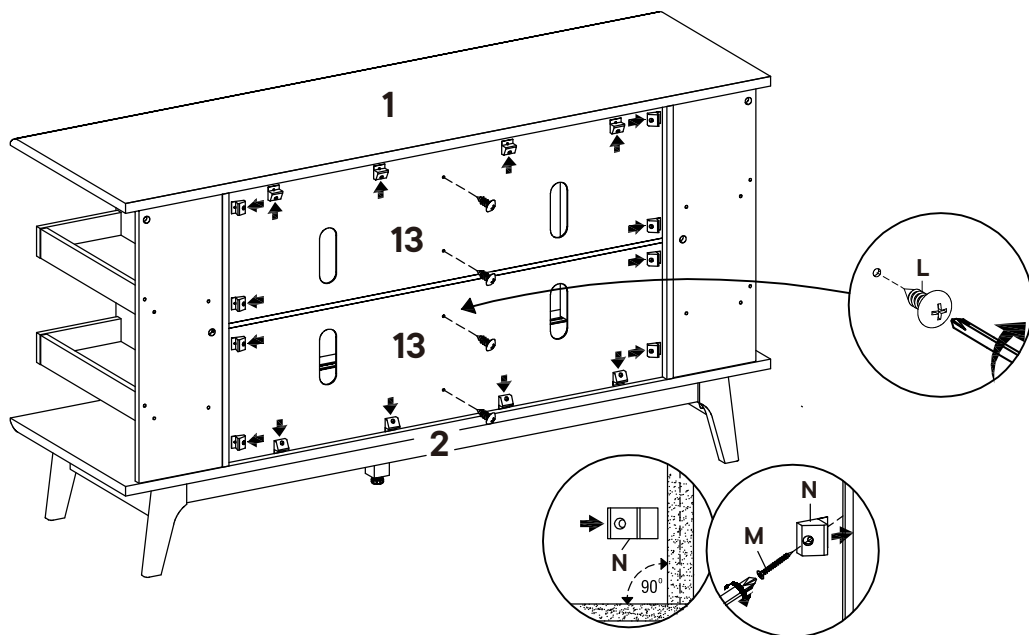

## Step 21

### HARDWARE

**K** Shelf Pin  $\varnothing 7 \times 16.5 \text{ mm}$  x16

### COMPONENTS

**3** Left Side Bord x1

**4** Right Side Board x1

**5** Divider Board x1

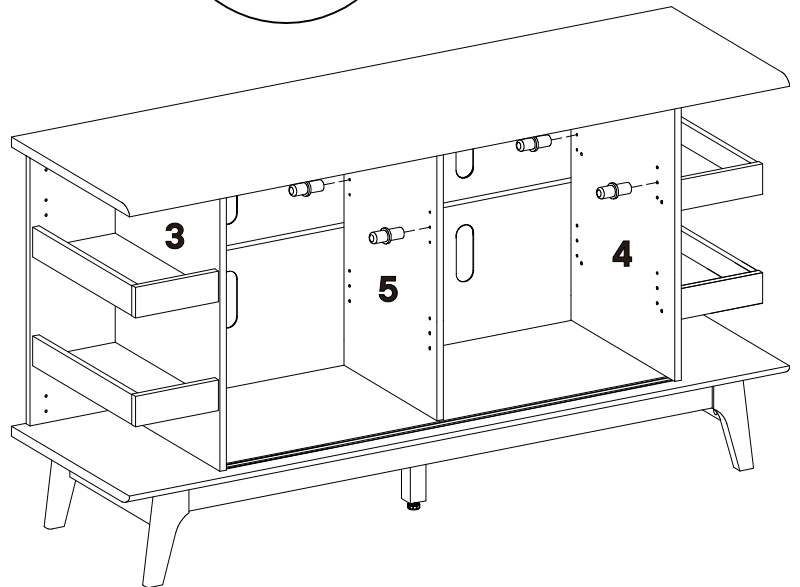
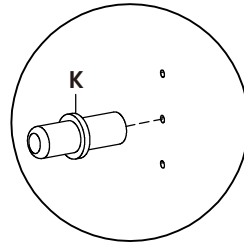

## Step 22

### COMPONENTS

**3** Left Side Bord x1

**4** Right Side Board x1

**5** Divider Board x1

**8** Adjustable Shelf x4

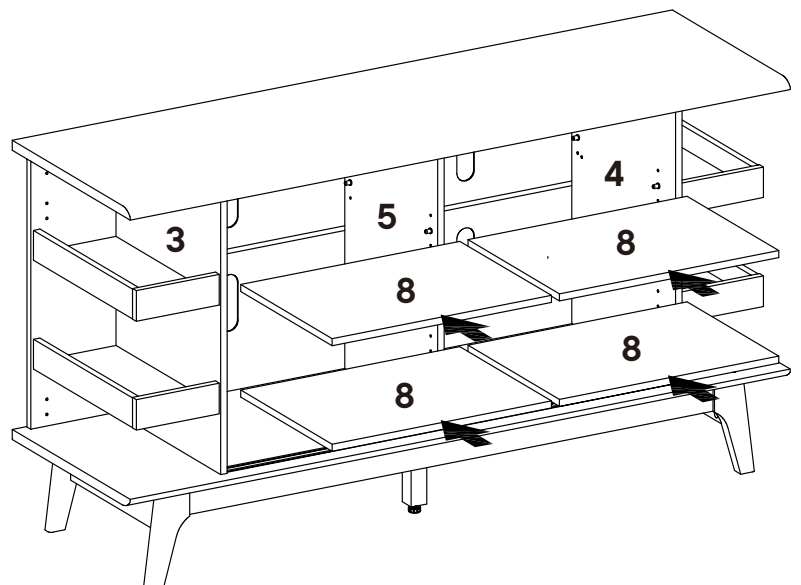

# Step 23

## HARDWARE

- O** Top Door Pin x2
- P** Bottom Door Pin x2

## COMPONENTS

- 23** Door x1

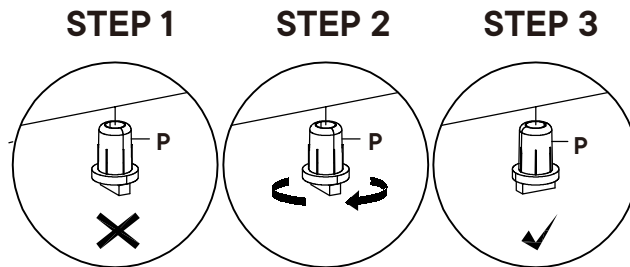
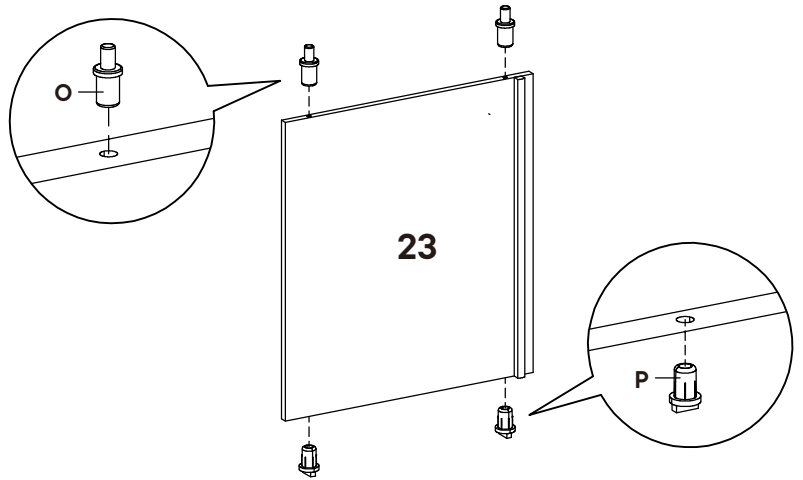

# Step 24

## HARDWARE

- Q** Buffer x4

## COMPONENTS

- 1** Top Board x1
- 2** Bottom Board x1
- 23** Door x1

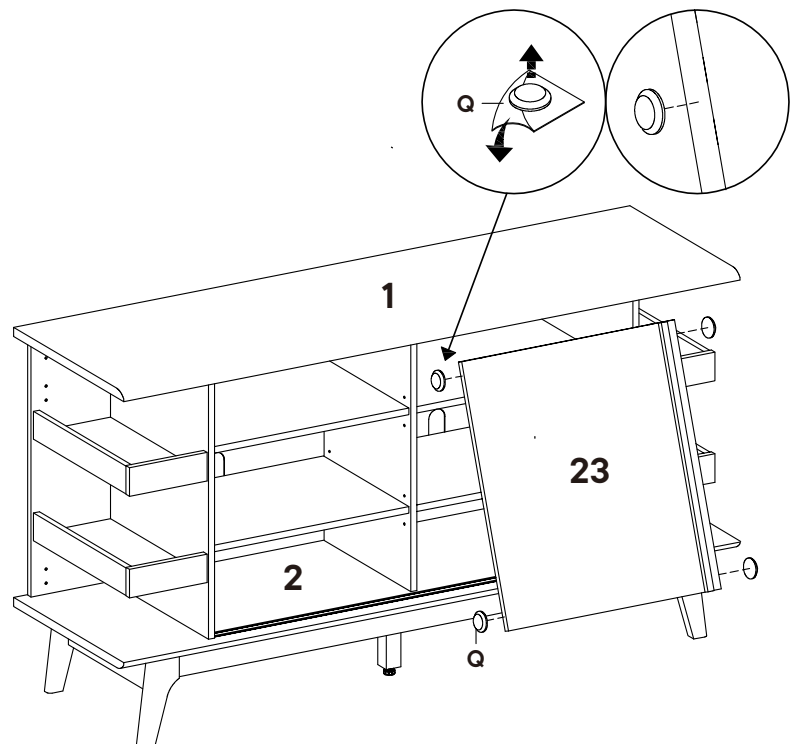
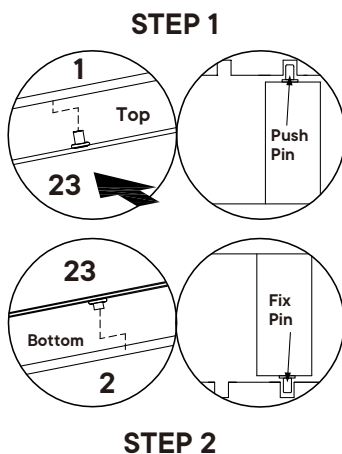



# Step 25

## HARDWARE

- O** Top Door Pin x2
- P** Bottom Door Pin x2

## COMPONENTS

- 23** Door x1

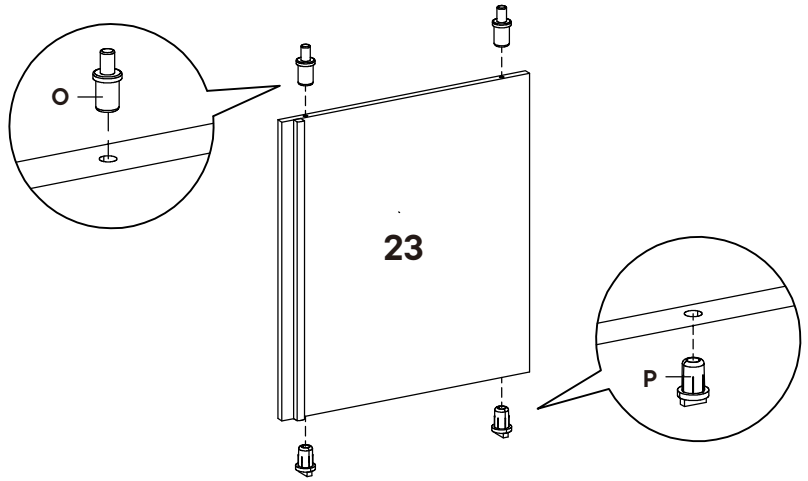

### STEP 1

### STEP 2

### STEP 3

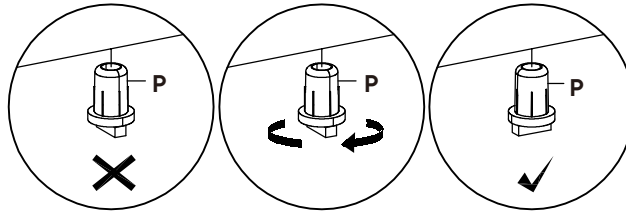

# Step 26

## HARDWARE

- Q** Buffer x4

## COMPONENTS

- 23** Door x1

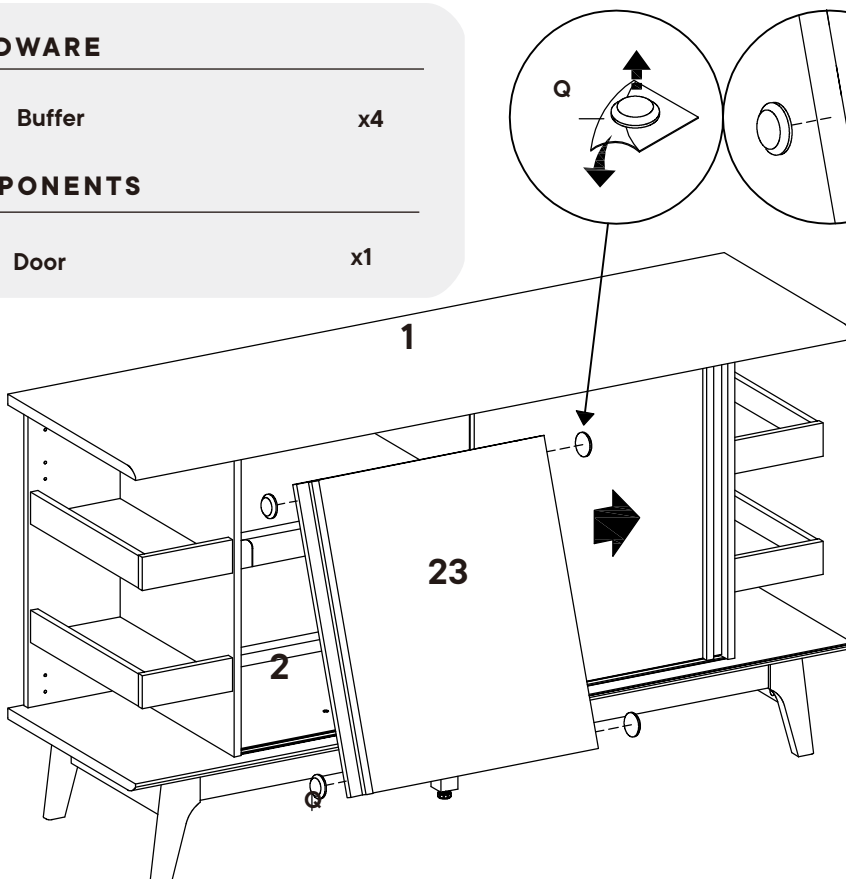

### STEP 1

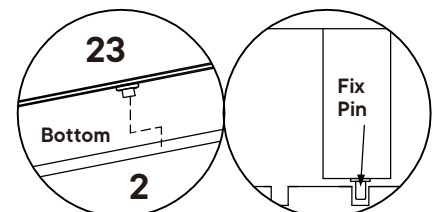
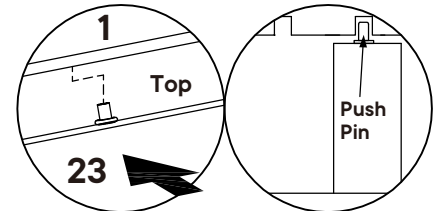

### STEP 2

# Step 27

## HARDWARE

- D** Plastic Dowel Ø8 x 32 mm x2
- E** Door Hinge x3
- R** Screw M 4 x 10 mm x10
- S** Corner Bracket x2

## COMPONENTS

- 20** Left Side Door Support x1

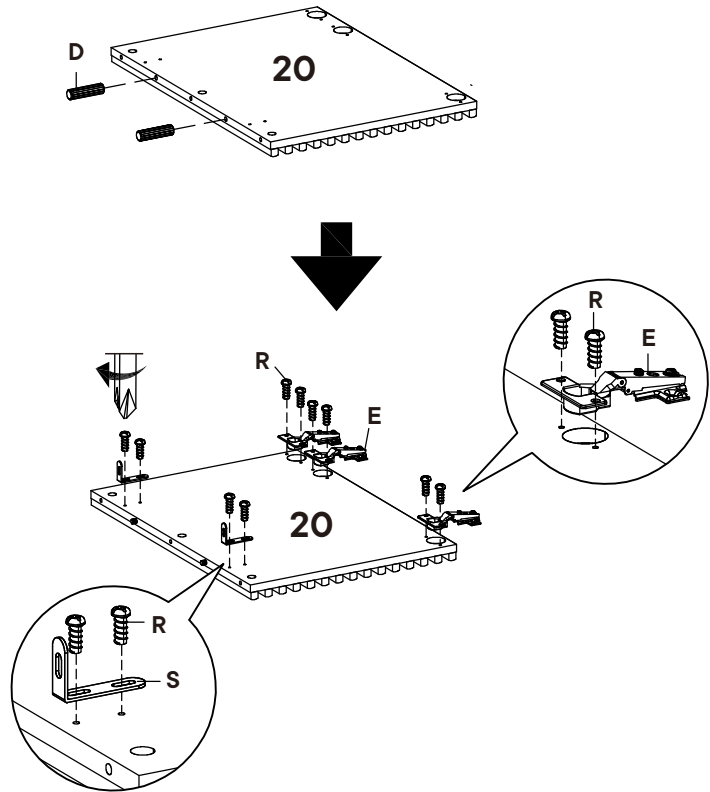

# Step 28

## HARDWARE

- D** Cam Bolt Ø7.5 x 32 mm x6
- E** Plastic Dowel Ø8 x 32 mm x2
- R** Door Hinge x3
- S** Screw M 4 x 10 mm x10
- S** Corner Bracket x2

## COMPONENTS

- 21** Right Side Door Support x1
- 22** Side Door x2

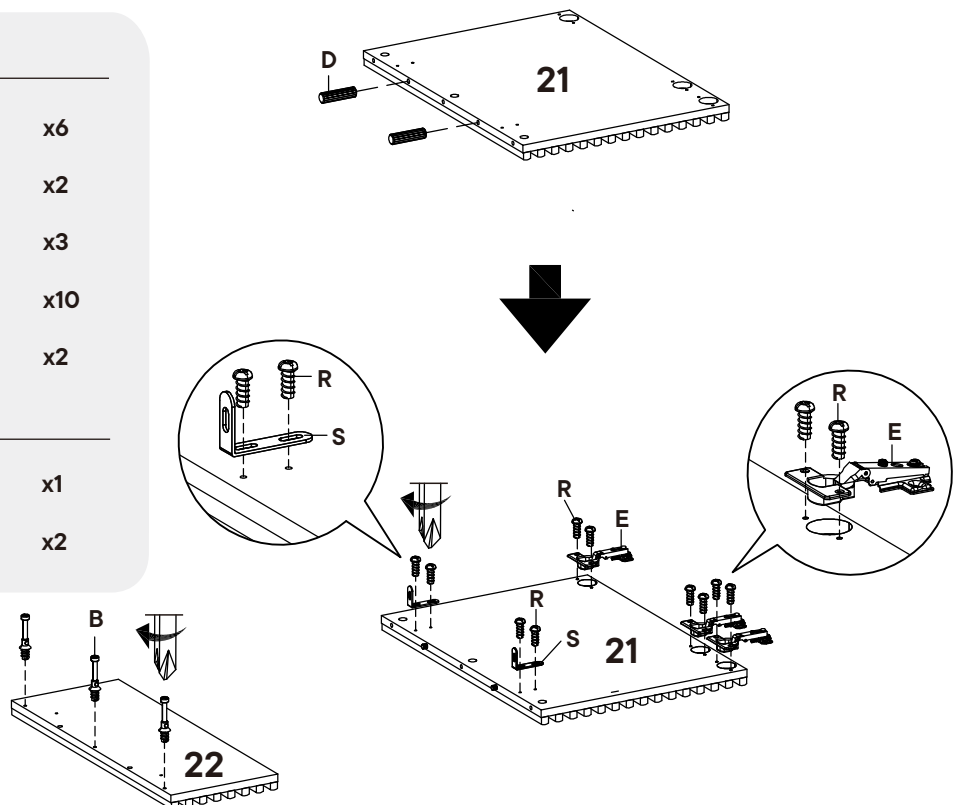

# Step 29

## HARDWARE

<b>A</b>	Cam Lock Ø15 mm	x6
<b>C</b>	Cam Cover Ø17 mm	x6
<b>R</b>	Screw M 4 x 10 mm	x4
<b>U</b>	Washer Plate Ø13 mm	x4

## COMPONENTS

<b>20</b>	Left Side Door Support	x1
<b>21</b>	Right Side Door Support	x1
<b>22</b>	Side Door	x2

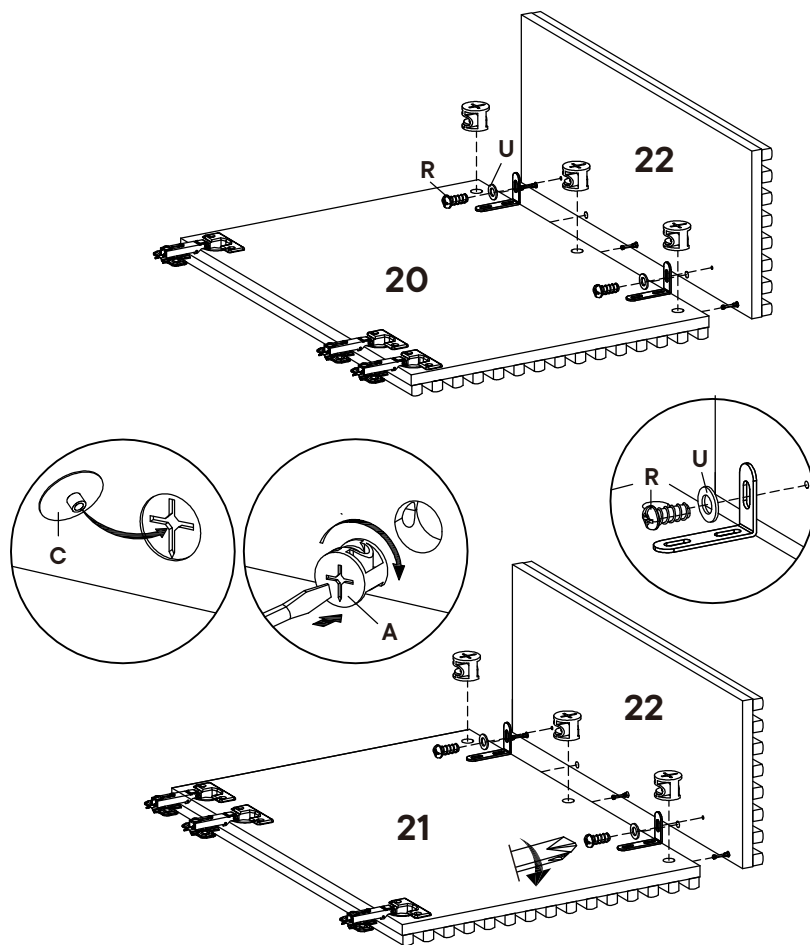

# Step 30

## COMPONENTS

- 6 Back Left Shelf Support x1
- 7 Back Right Shelf Support x1
- 20 Left Side Door Support x1
- 21 Right Side Door Support x1

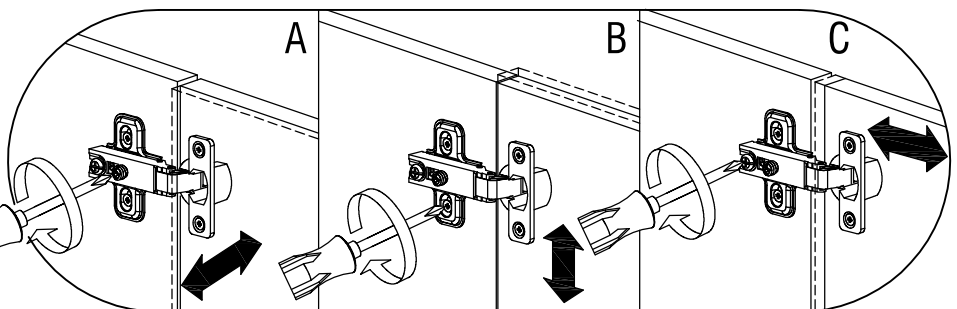
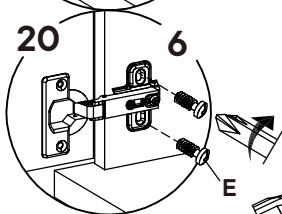
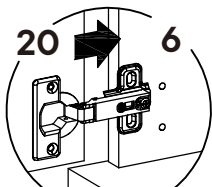
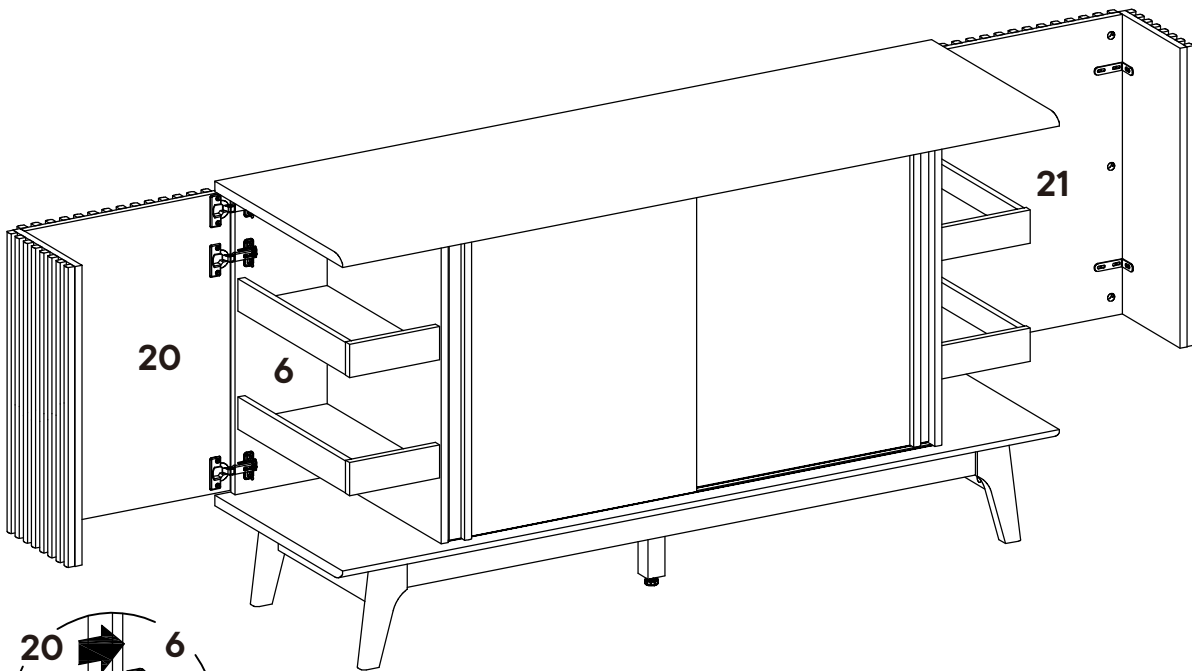

# Step 31

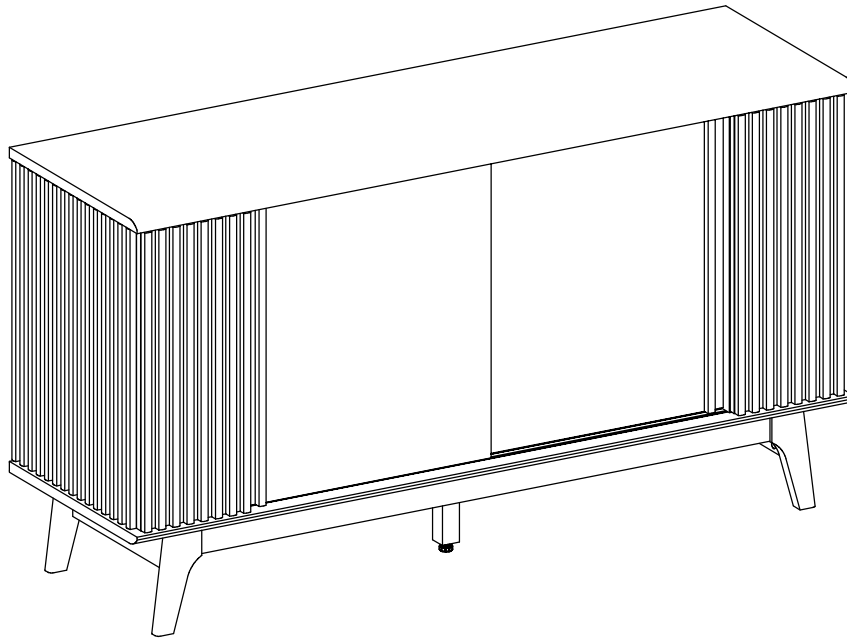

### ADJUSTABLE FEET

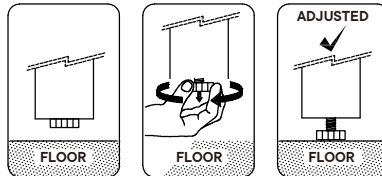

# Great job!

Sideboard assembly is complete.



## CARING FOR YOUR ITEM

Indoor use only.

Not contract grade.

Clean using a non-abrasive cloth and a mild cleaner.

Never use harsh chemicals, as they could damage the finish or integrity of the item.

## CONNECT WITH US!

Tag us @modway\_furniture and #modway for a chance to be featured.

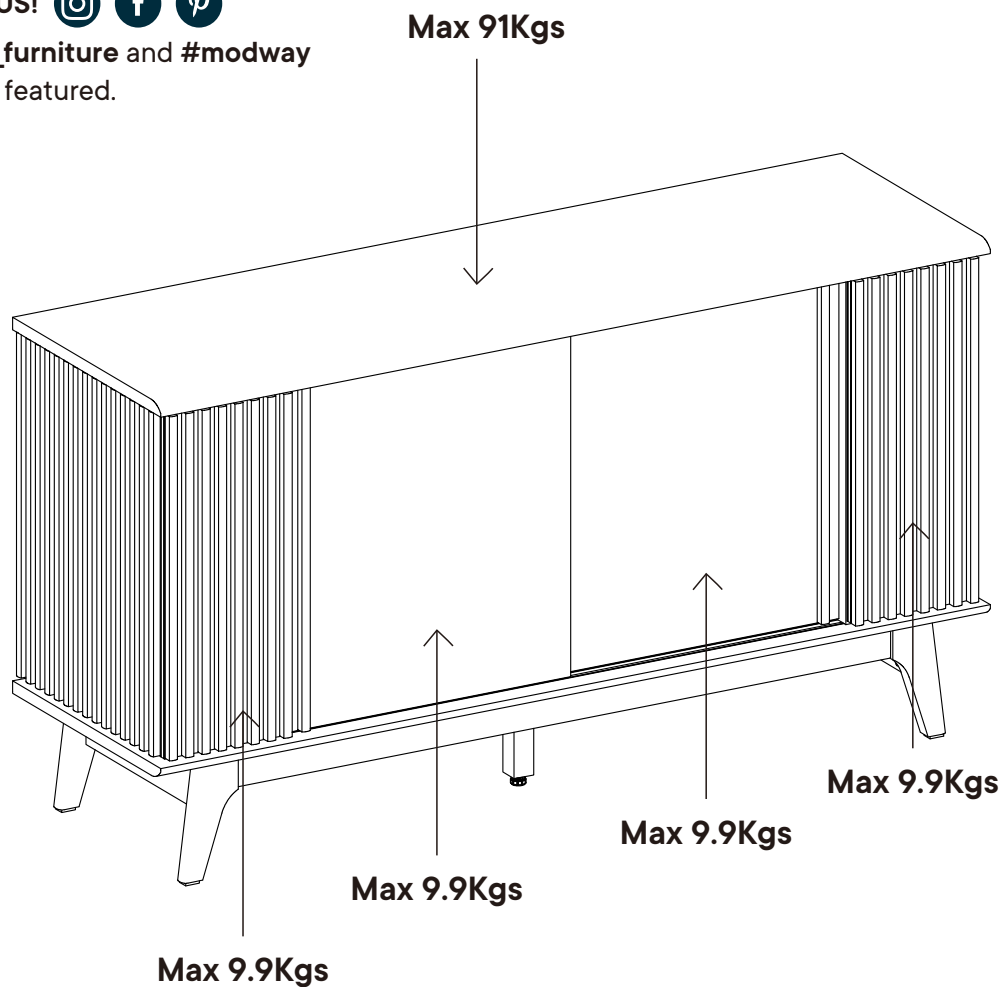

## TIPPING RESTRAINTS KIT INSTALLATION GUIDANCE

Different wall materials require unique wall fasteners.

Please consult your local hardware store to ensure you are using the correct hardware for you wall type.

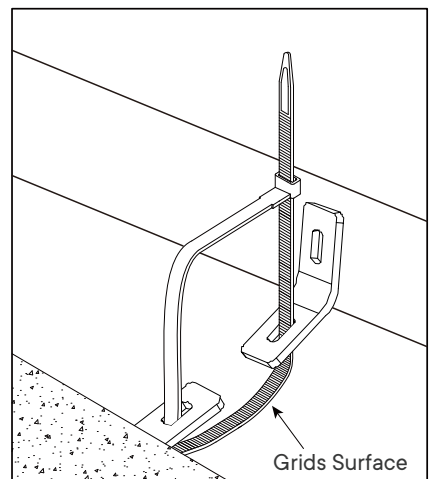
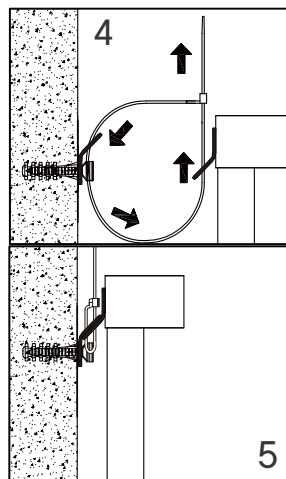
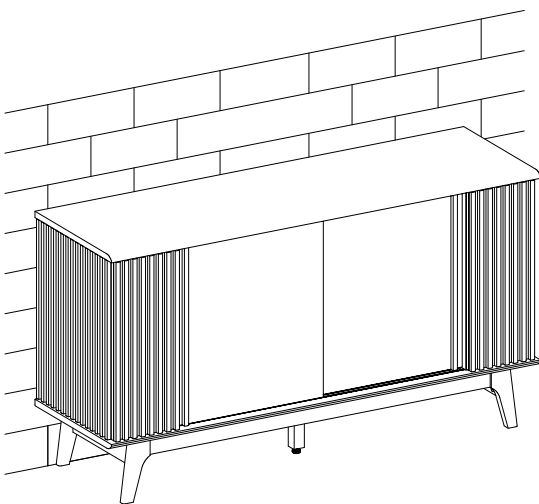
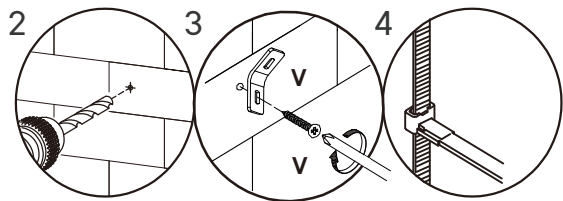
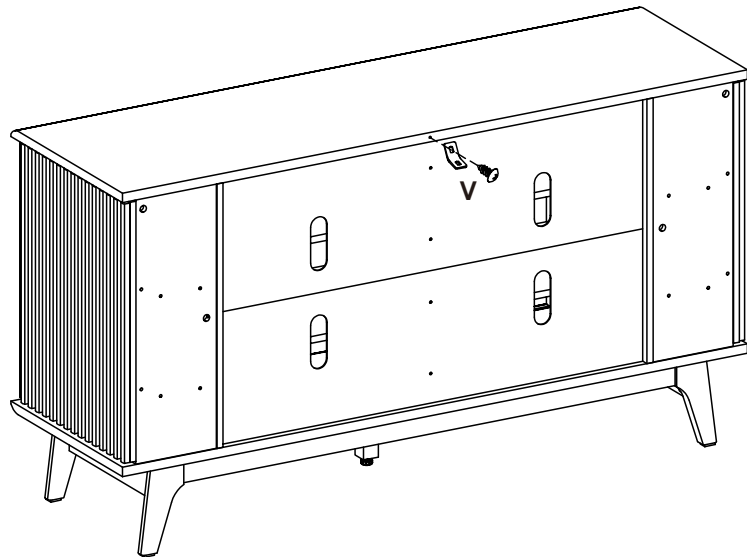
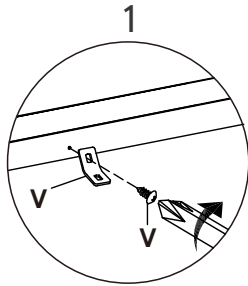
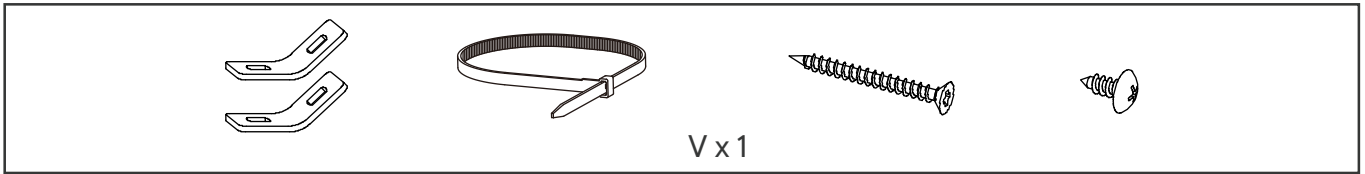

### Installation Instructions :

1. Attach bracket (V) securely to the back top of the furniture using short screw (V) provided.
2. Please make a hole on the wall for attach the bracket (V) to the back of unit.
3. Attach bracket (V) on the wall using long screw (V) as shown.  
Locate the other bracket (V) on the wall. Place furniture into position so both brackets (V) as shown.
4. Lace the end of the restrains strap through the larger hole in each bracket. Ensure the restrains strap with grids surface facing the inner loops. Bring both ends together and slide the flat end through the locking end and draw it through until all slack is removed.
5. Make sure that the strap is securely laced & locked.