

ASSEMBLY INSTRUCTIONS

EEI-6203

V0.09.08.22

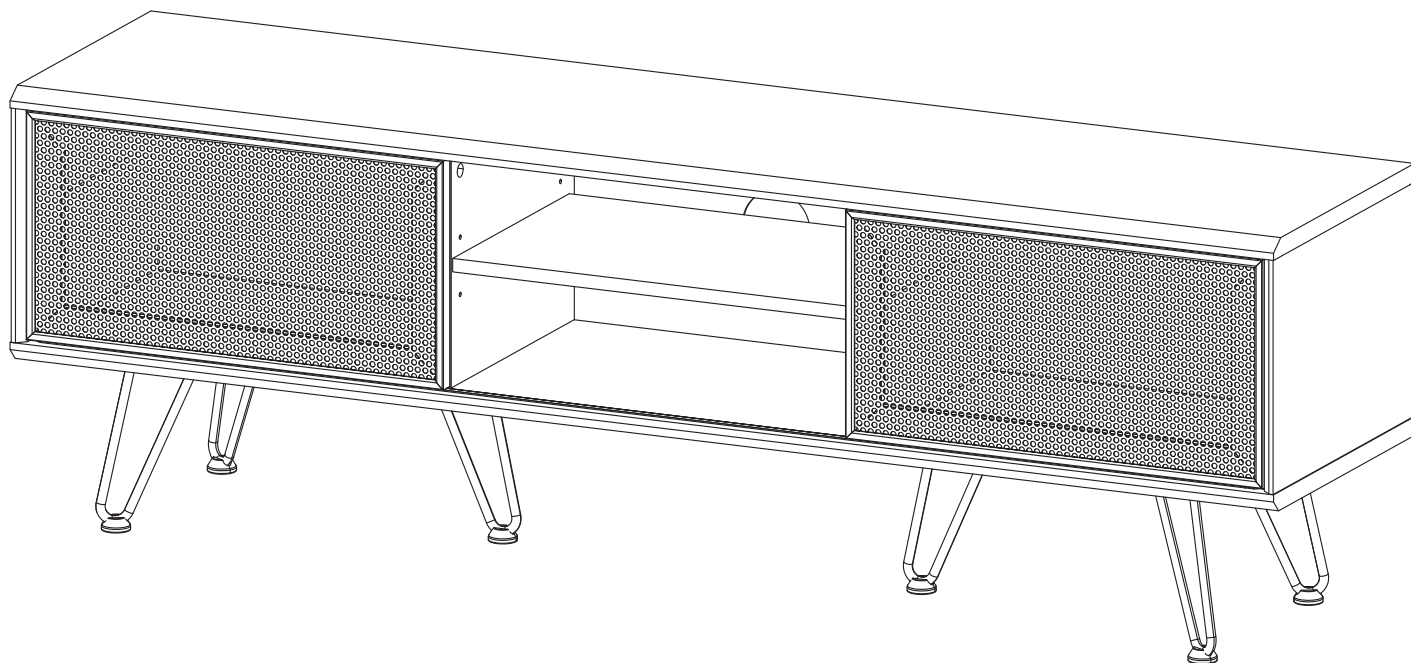

Questions? Contact us!

609.256.9000 • cs@modway.com
www.modway.com

*modway

Let's get started!

*modway



Read through all of the instructions before starting



Care instructions are listed in the last step of this manual

Only use hand tools to assemble this item. Do not use power tools. Do not tighten bolts or screws completely until all hardware is lined up and inserted into the holes.



Approx. 60 minutes assembly time



Make sure you have all parts and components before discarding any packing materials

Do not over-tighten screws and bolts to avoid stripping the hardware or cracking the item.

Assemble your item on a flat, carpeted area, with plenty of space to work. This will prevent damage and scratches to your floors or the item while you're assembling the product.



2 people recommended for assembly

Keep all components and packaging out of reach of children or animals to avoid risk of choking or suffocation.

Furniture components:

1	Top Board	x1
2	Bottom Board	x1
3	Side Board Left	x1
4	Side Board Right	x1
5	Center Board	x2
6	Adjustable Shelf	x3
7	Door	x2
8	Back Board	x3

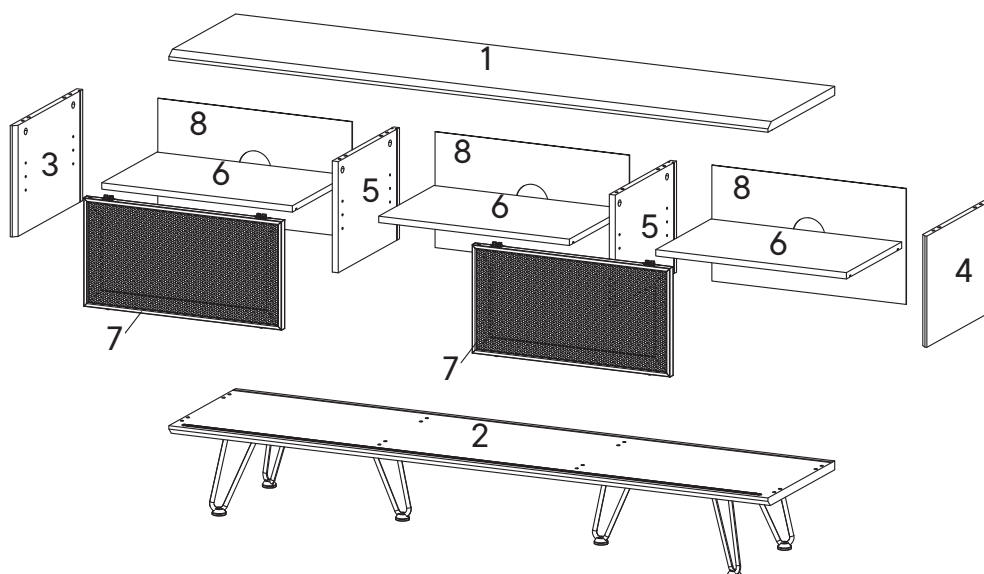

Provided hardware:

A		Cam Bolt $\varnothing 6 \times 35$ mm	x8
B		Cam Lock $\varnothing 15$ mm	x8
C		Wood Dowel $\varnothing 8 \times 30$ mm	x16
D		Screw M 7 x 50 mm	x8
E		Screw M 3.5 x 13 mm	x16
F		Screw Cap $\varnothing 15$ mm	x8
G		Allen Key	x2
H		Wedge	x18
I		Screw M 3.5 x 15.5 mm	x18

J		Shelf Pin	x12
K		Silicon Bumper	x3
L		Screw M 4.5 x 12.5 mm	x24
M		Floor Pad	x6
N		Sliding Top	x4
O		Sliding Bottom	x4
LM19A1		Leg Hairpin	x6

What you need:

Phillips Head Screwdriver

Wait!

Missing parts or hardware? Need assistance?
Contact us before returning your item. We're here to help!
609.256.9000 • cs@modway.com

Step 1

HARDWARE

- A** Cam Bolt Ø6 x 35 mm x8
- C** Wood Dowel Ø8 x 30 mm x16

COMPONENTS

- 1** Top Board x1
- 3** Side Board Left x1
- 4** Side Board Right x1
- 5** Center Board x2

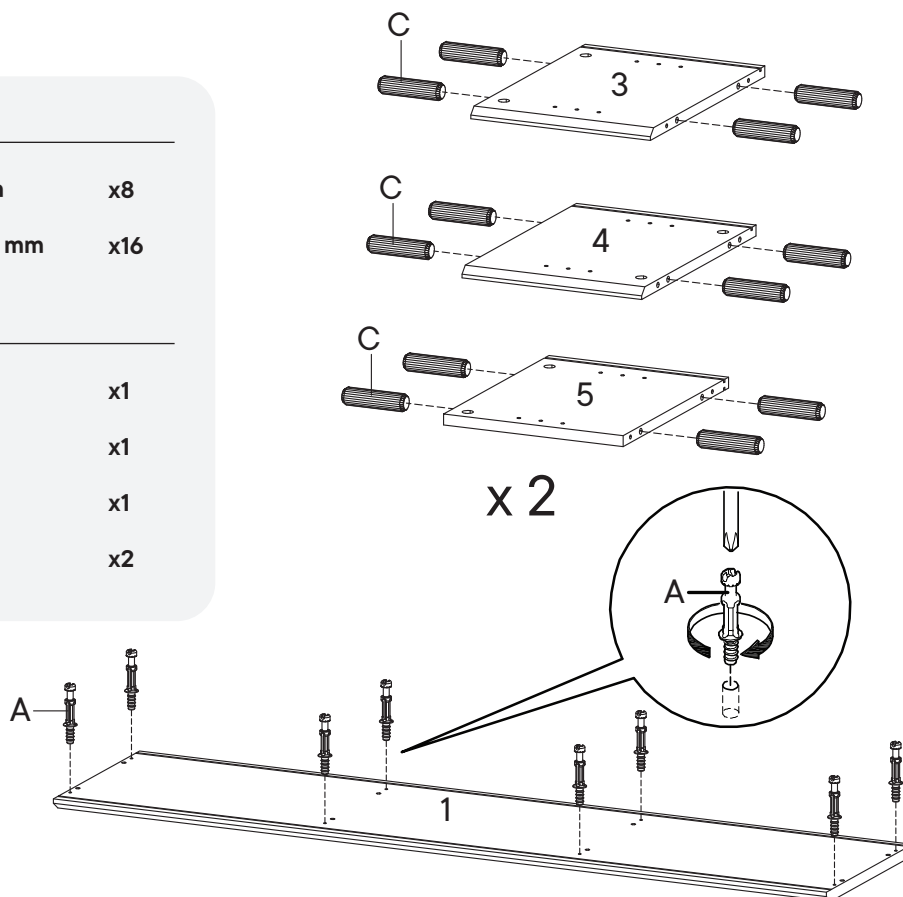

Step 2

HARDWARE

- B** Cam Lock Ø15 mm x8
- F** Screw Cap Ø15 mm x8

COMPONENTS

- 1** Top Board x1
- 3** Side Board Left x1
- 4** Side Board Right x1
- 5** Center Board x2

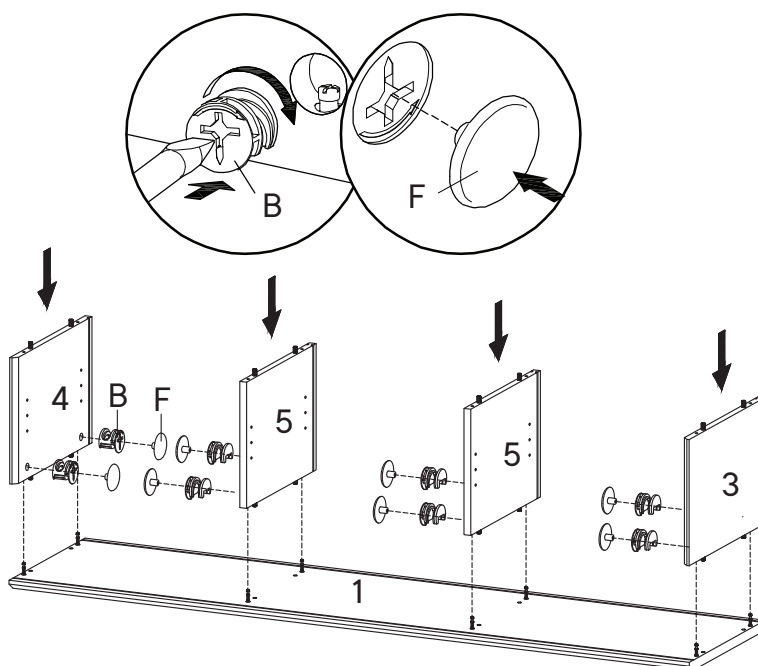

Step 3

HARDWARE

- D** Screw M 7 x 50 mm x8
- G** Allen Key x1

COMPONENTS

- 2** Bottom Board x1
- 8** Back Board x3

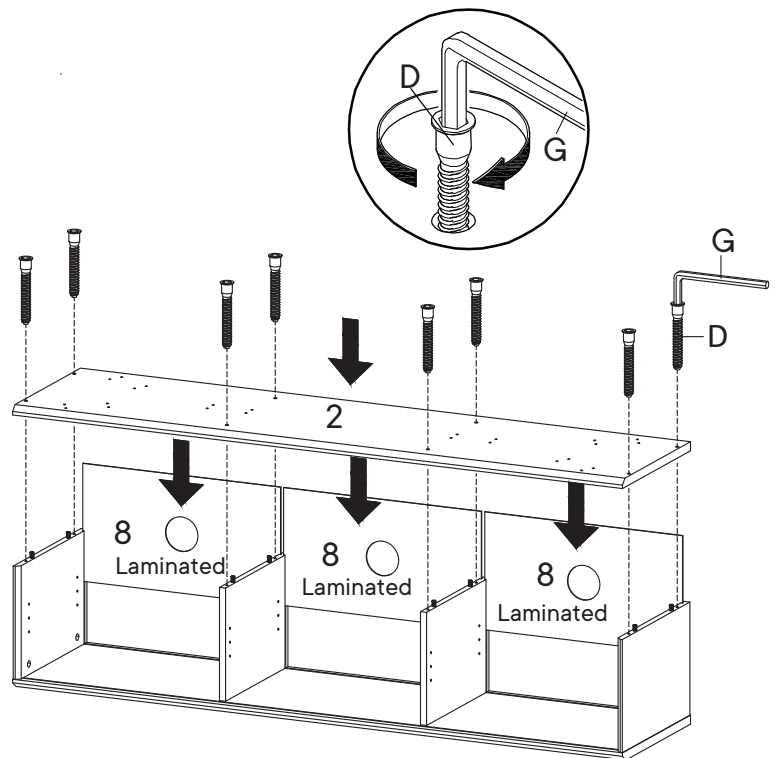

Step 4

HARDWARE

- L** Screw M 4.5 x 12.5 mm x24
- LM19A1** Leg Hairpin x6

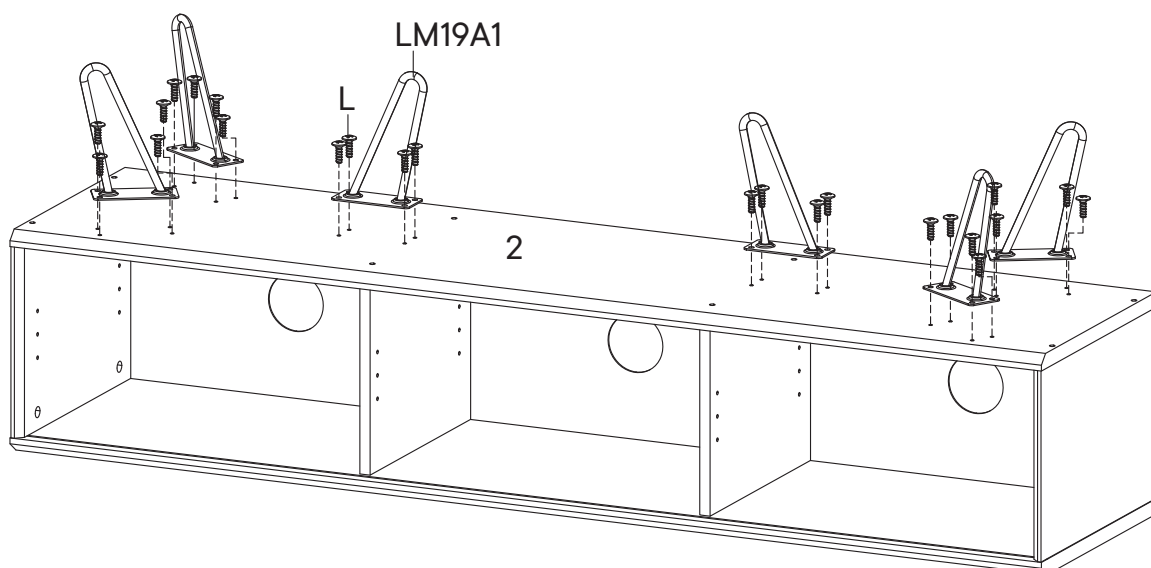
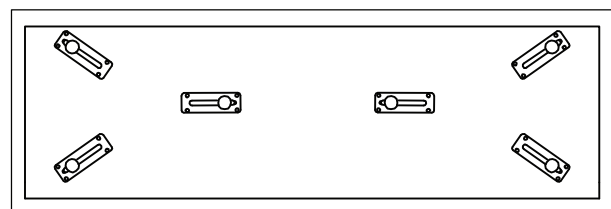

Step 5

HARDWARE

M Floor Pad x6

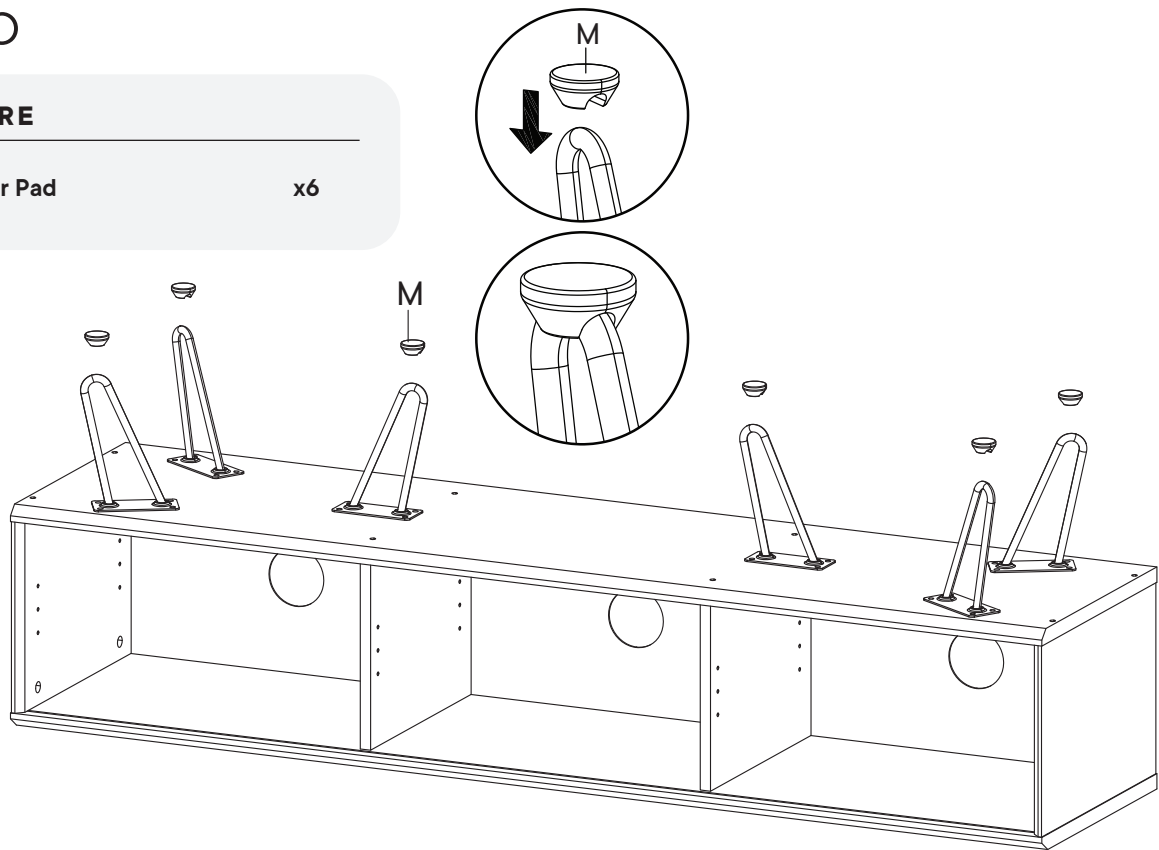

Step 6

HARDWARE

J Shelf Pin x12

COMPONENTS

6 Adjustable Shelf x3

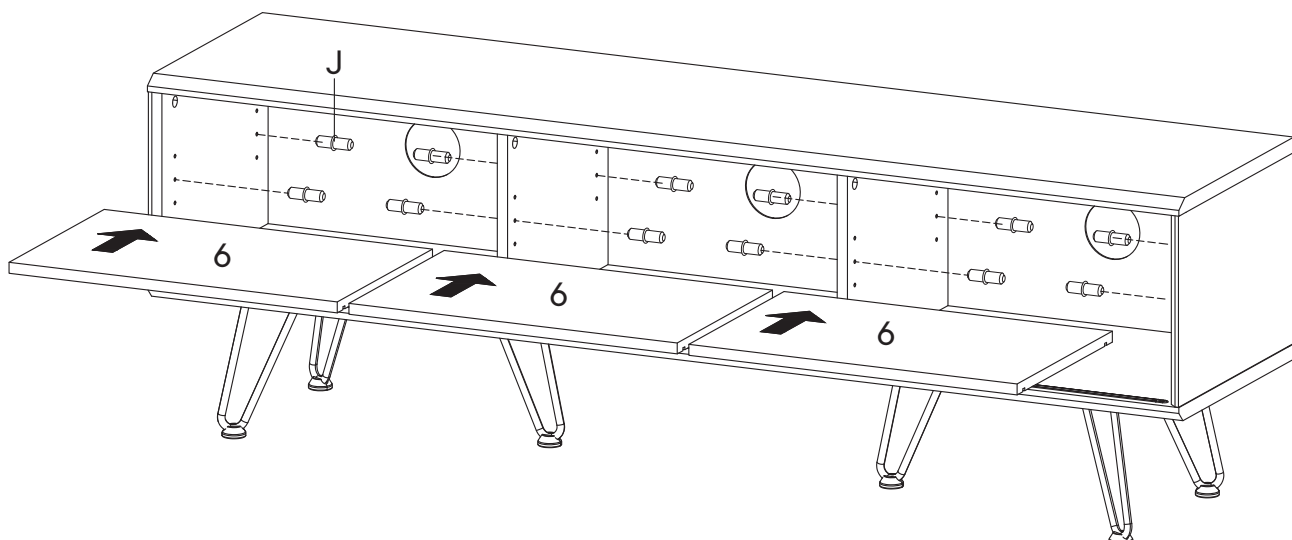
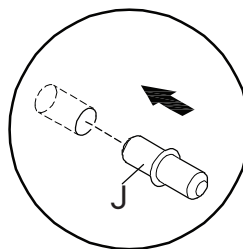

Step 7

HARDWARE

- E** Screw M 3.5 x 13 mm x16
- N** Sliding Top x4
- O** Sliding Bottom x4

COMPONENTS

- 7** Door x2

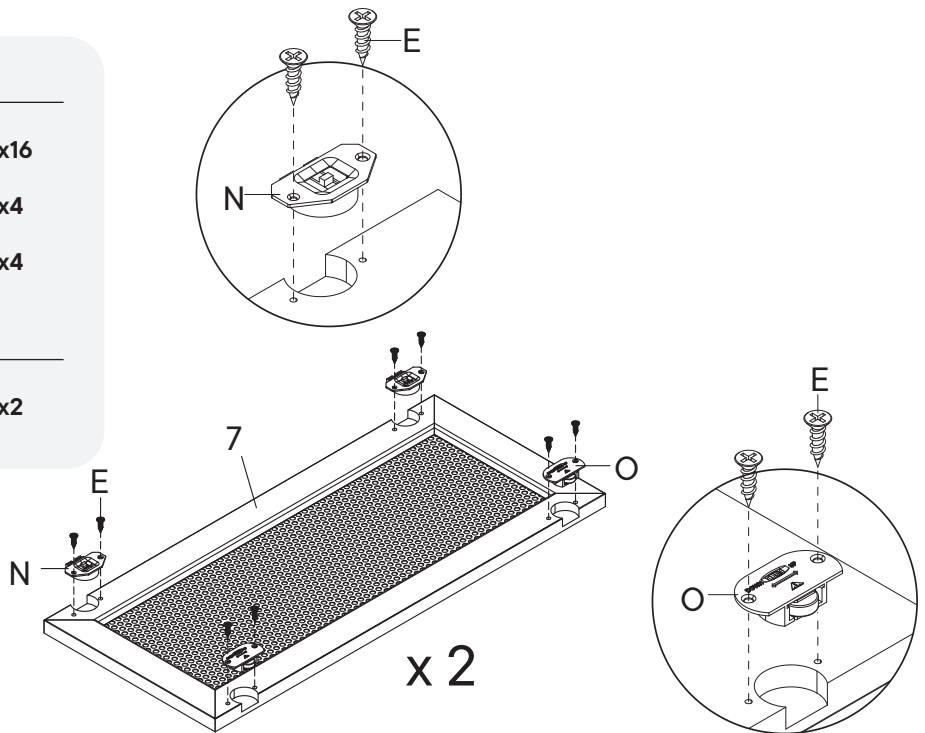

Step 8

HARDWARE

- K** Silicon Bumper x3

COMPONENTS

- 7** Door x2

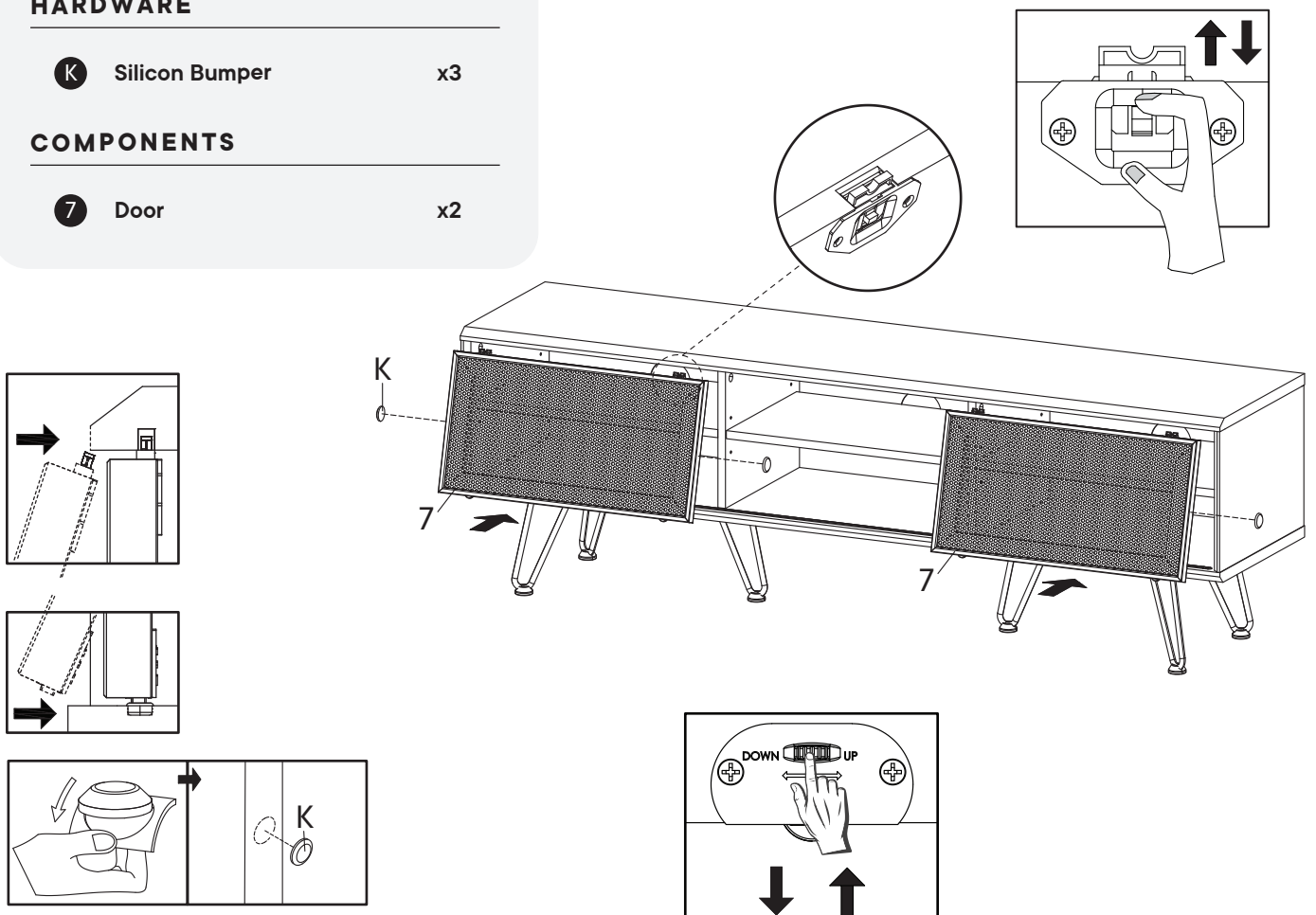

Step 9

HARDWARE

- H** Wedge x18
- I** Screw M 3.5 x 15.5 mm x18

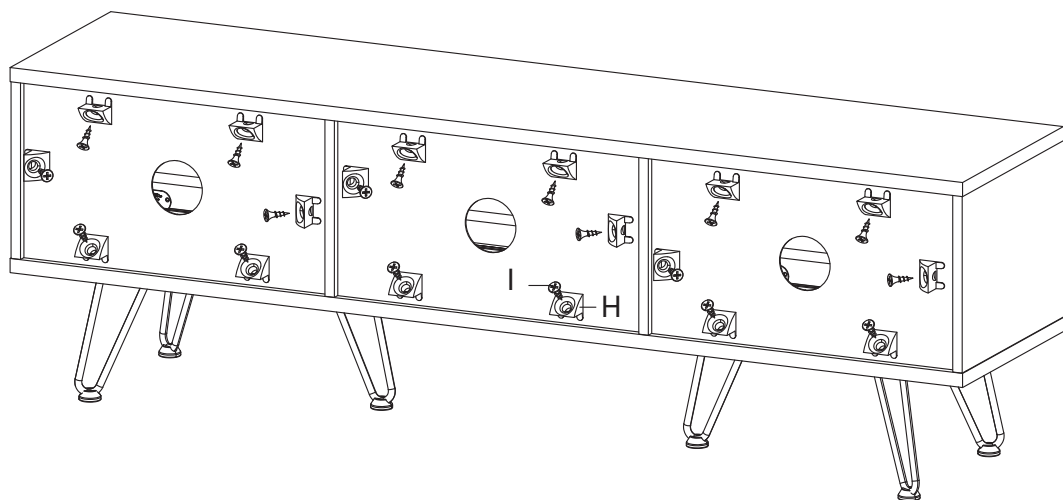
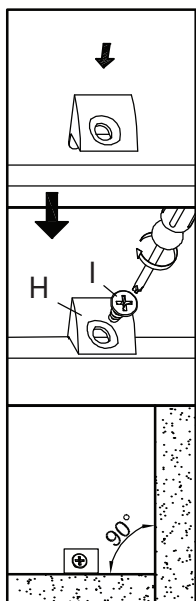

Great job!

Tv Stand assembly is complete.

♥ CARING FOR YOUR ITEM

Indoor use only.

Not contract grade.

Clean using a non-abrasive cloth and a mild cleaner.

Never use harsh chemicals, as they could damage the finish or integrity of the item.

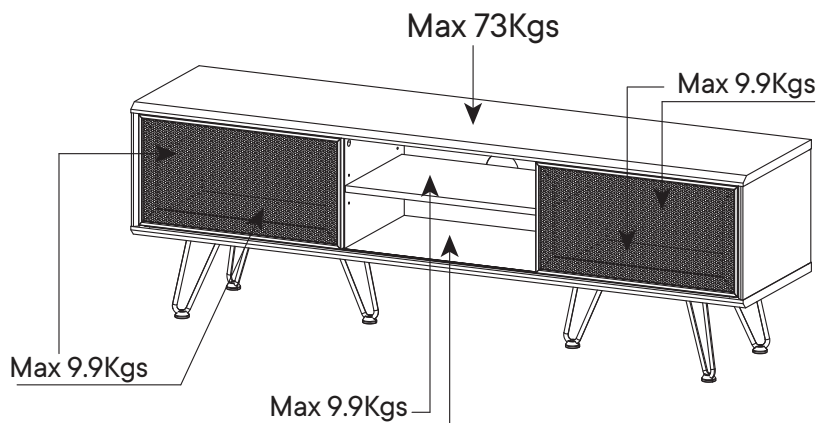

CONNECT WITH US!

Tag us @modway_furniture and #modway for a chance to be featured.