

ASSEMBLY INSTRUCTIONS

EEI-6046

V0.01.20.22

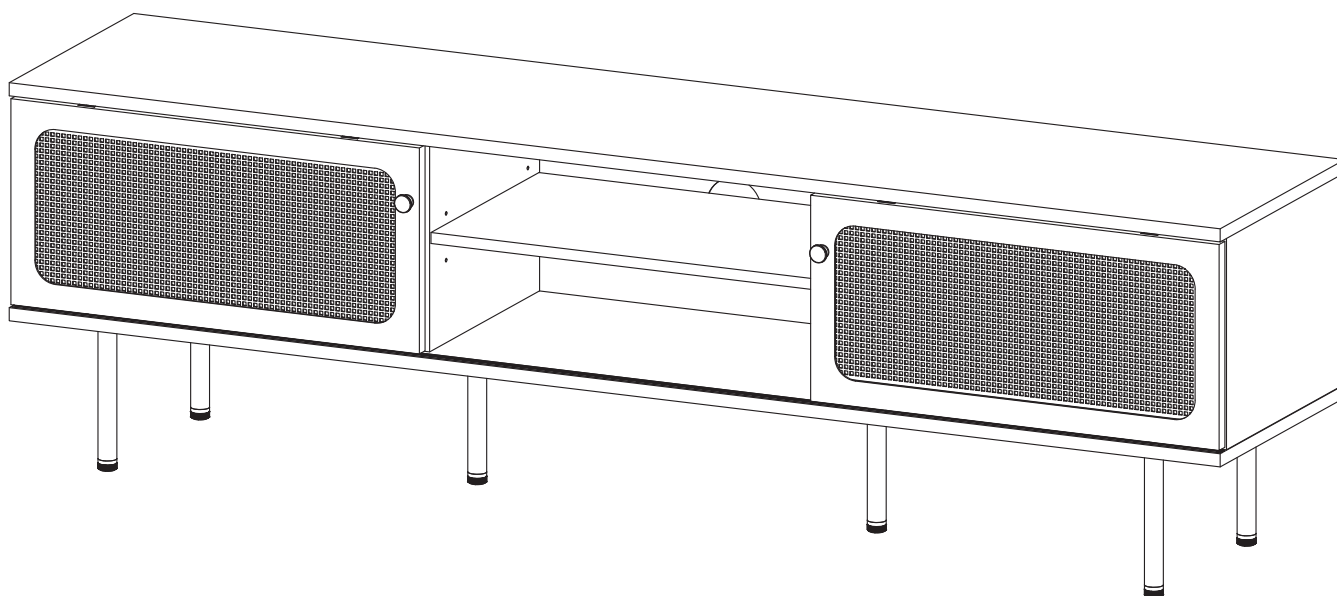

Questions? Contact us!

609.256.9000 • cs@modway.com
www.modway.com

*modway

For use with televisions weighing a maximum of 135 lb / 61.4 kg or less, with a maximum width of 60 inches / 152.4 cm.

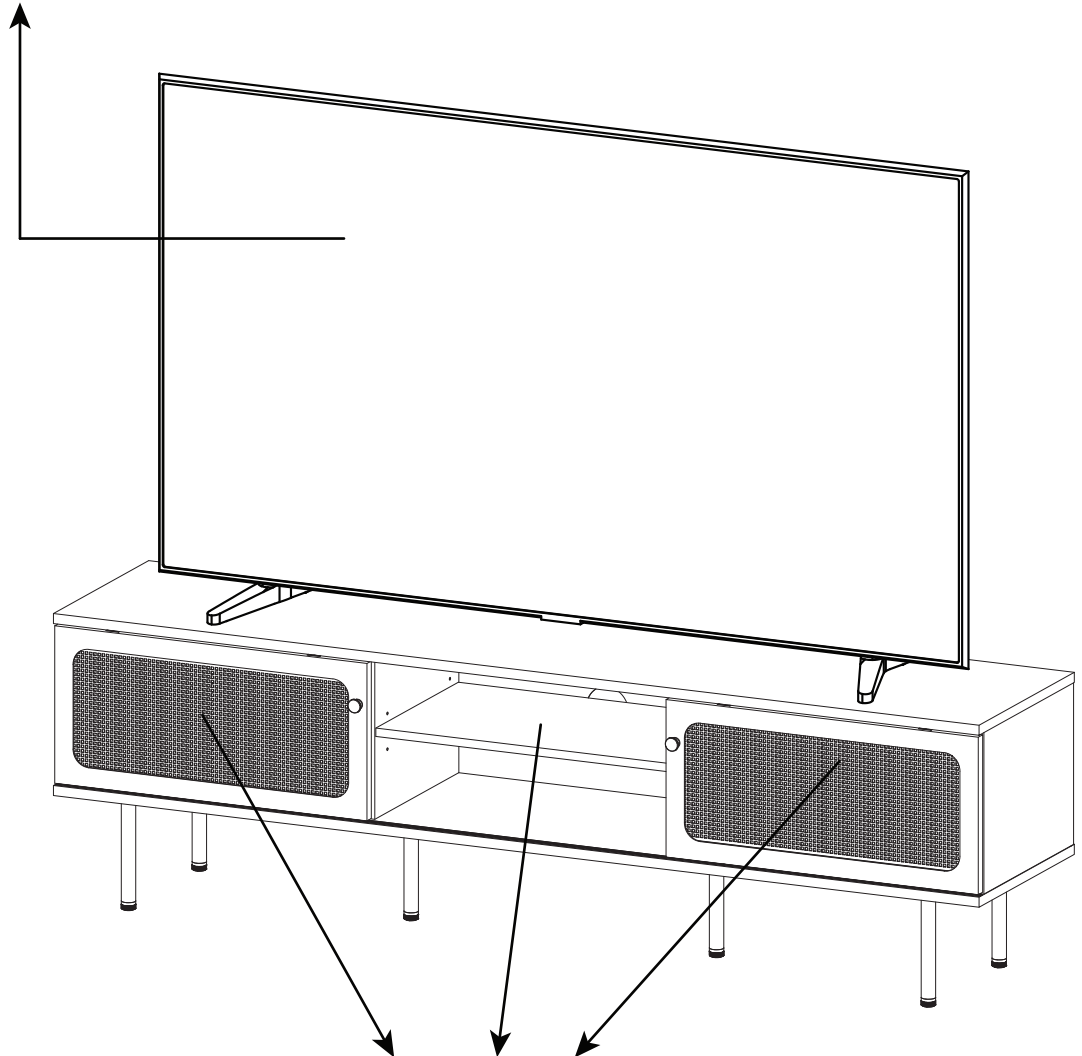

22 lb / 9.9 kg weight limit per shelf



Read through all of the instructions before starting



Care instructions are listed in the last step of this manual



Approx. 60 minutes assembly time



Make sure you have all parts and components before discarding any packing materials



2 people recommended for assembly

Only use hand tools to assemble this item. Do not use power tools. Do not tighten bolts or screws completely until all hardware is lined up and inserted into the holes.

Do not over-tighten screws and bolts to avoid stripping the hardware or cracking the item.

Assemble your item on a flat, carpeted area, with plenty of space to work. This will prevent damage and scratches to your floors or the item while you're assembling the product.

Keep all components and packaging out of reach of children or animals to avoid risk of choking or suffocation.

Furniture components:

1	Top Board	x1
2	Bottom Board	x1
3	Side Board Left	x1
4	Side Board Right	x1
5	Adjustable Shelf	x3
6	Center Board	x2
7	Back Board	x3
8	Door Right	x1
9	Door Left	x1

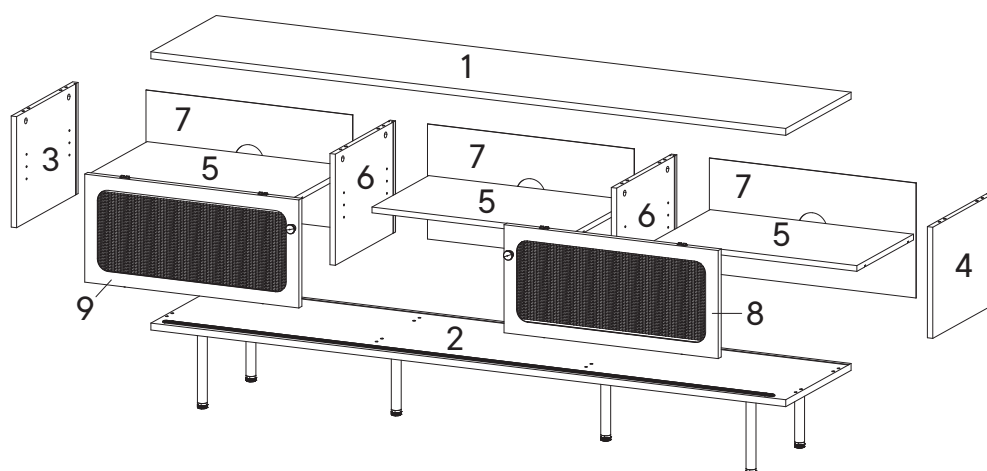

Provided hardware:

A		Cam Bolt $\varnothing 6 \times 35$ mm	x8
B		Cam Lock $\varnothing 15$ mm	x8
C		Wood Dowel $\varnothing 8 \times 30$ mm	x16
D		Allen Key	x1
E		Screw M 7 x 50 mm	x8
F		Screw Cap $\varnothing 15$ mm	x8
G		Stopper	x2
H		Screw M 3.5 x 13 mm	x16
I		Screw M 4 x 25 mm	x2

J		Screw M 4.5 x 12.5 mm	x24
K		Sliding Top	x4
L		Sliding Bottom	x4
M		Shelf Pin	x12
N		Wedge	x18
O		Screw M 3.5 x 15.5 mm	x18
P		Handle	x2
Q		Silicon Bumper	x1
LM20A1		Leg	x6

What you need:

Phillips Head Screwdriver

Wait!

Missing parts or hardware? Need assistance?
Contact us before returning your item. We're here to help!
609.256.9000 • cs@modway.com

Step 1

HARDWARE

- A** Cam Bolt $\varnothing 6 \times 35$ mm x8
- C** Wood Dowel $\varnothing 8 \times 30$ mm x16

COMPONENTS

- 1** Top Board x1
- 3** Side Board Left x1
- 4** Side Board Right x1
- 6** Center Board x2

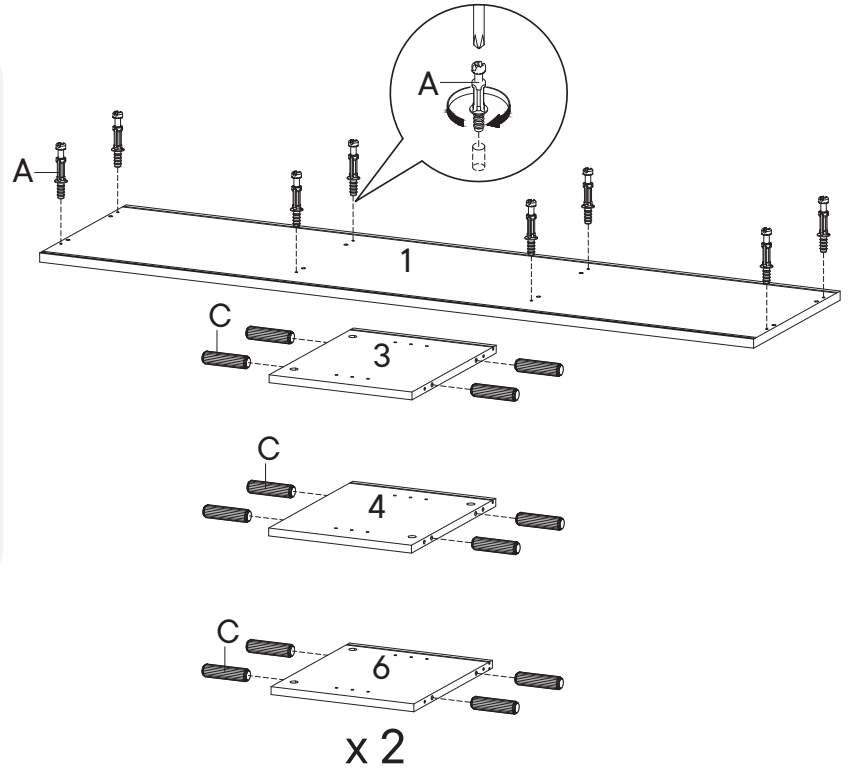

Step 2

HARDWARE

- B** Cam Lock $\varnothing 15$ mm x8
- F** Screw Cap $\varnothing 15$ mm x8

COMPONENTS

- 1** Top Board x1
- 3** Side Board Left x1
- 4** Side Board Right x1
- 6** Center Board x2

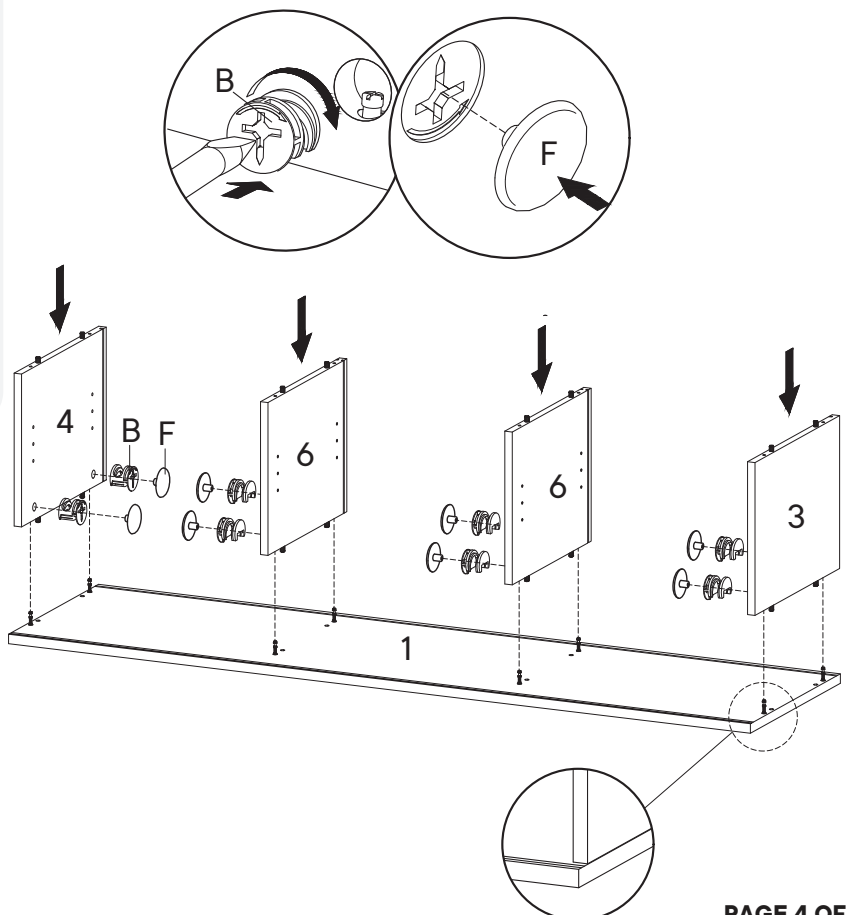
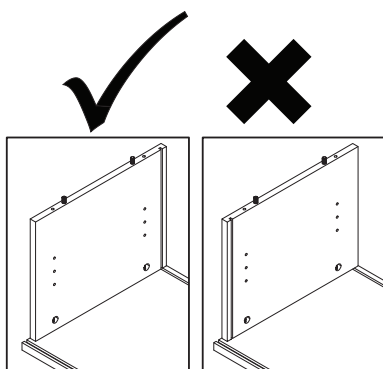

Step 3

HARDWARE

- D** Allen Key x1
- E** Screw M 7 x 50 mm x8

COMPONENTS

- 2** Bottom Board x1
- 7** Back Board x3

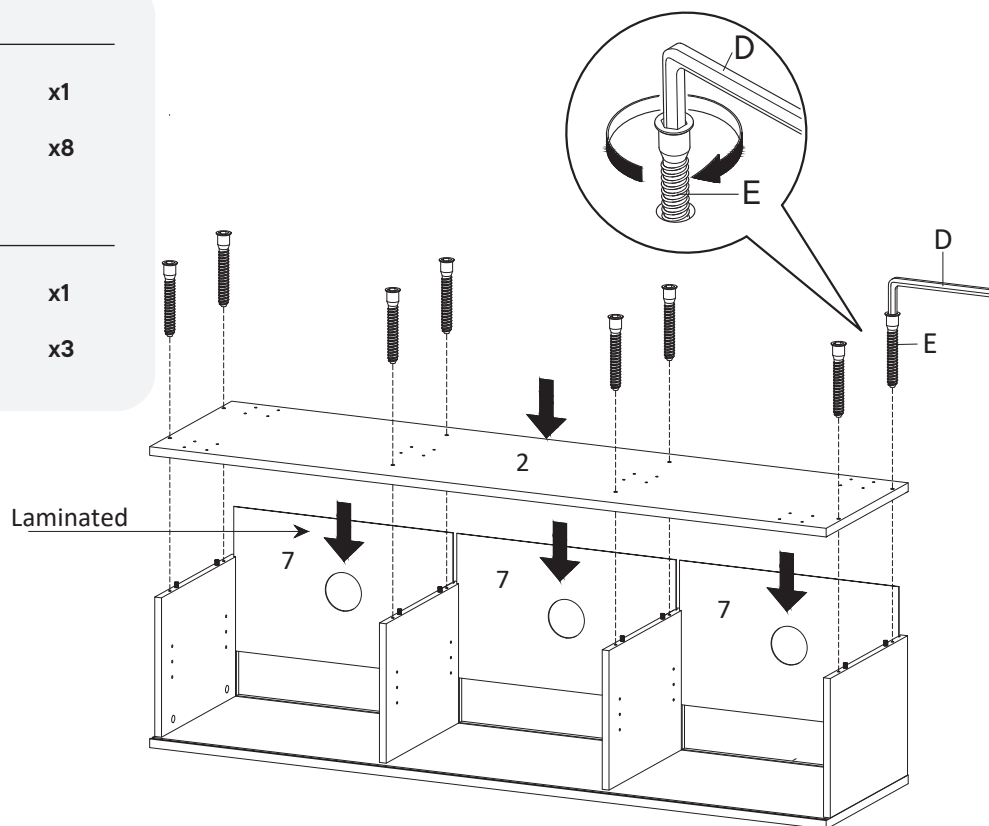

Step 4

HARDWARE

- J** Screw M 4.5 x 12.5 mm x24
- LM20A1** Leg x6

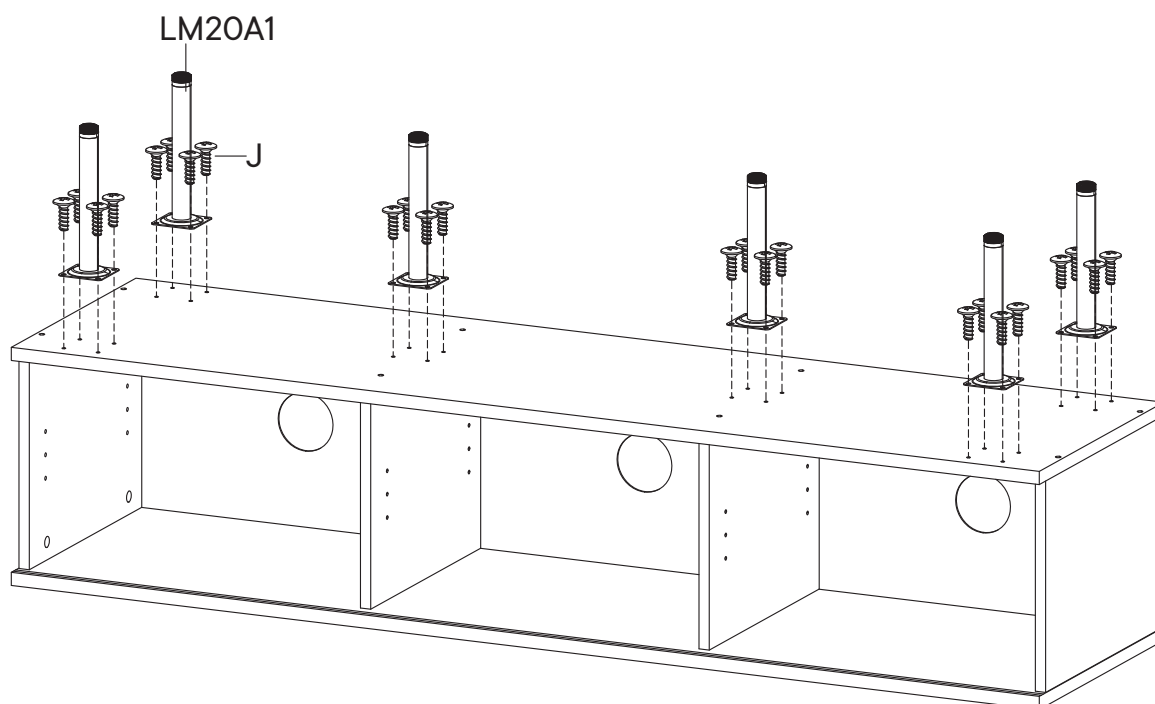

Step 5

HARDWARE

M Shelf Pin x12

COMPONENTS

5 Adjustable Shelf x3

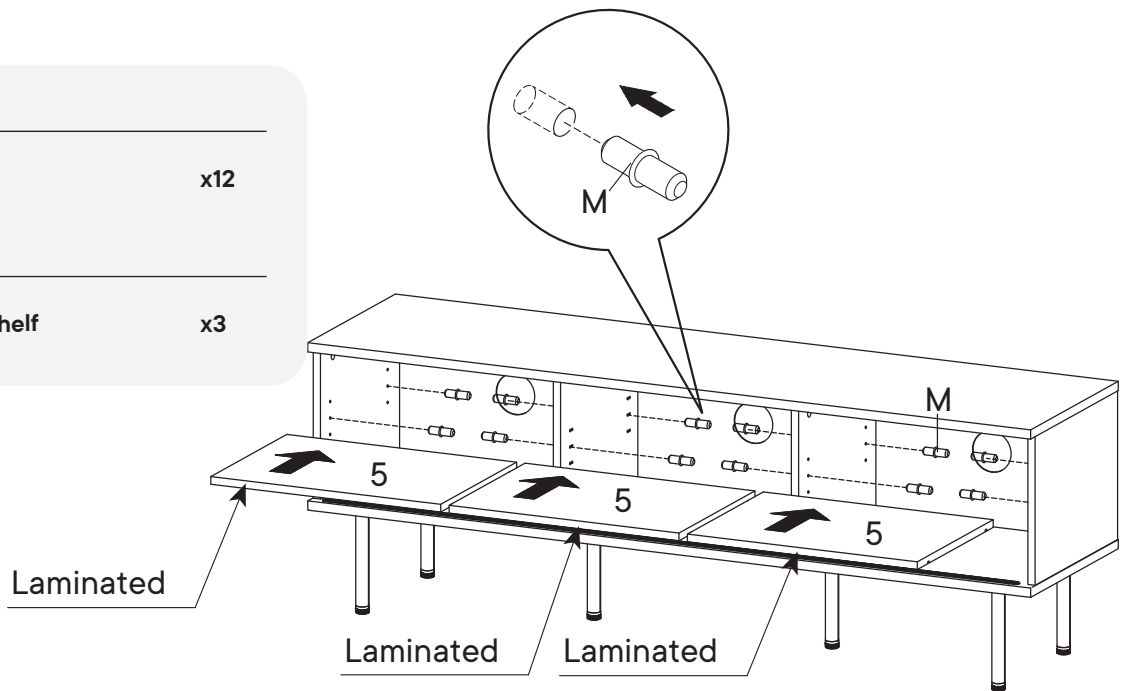

Step 6

HARDWARE

G Stopper x2

H Screw M 3.5 x 13 mm x16

K Sliding Top x4

L Sliding Bottom x4

COMPONENTS

8 Door Right x1

9 Door Left x1

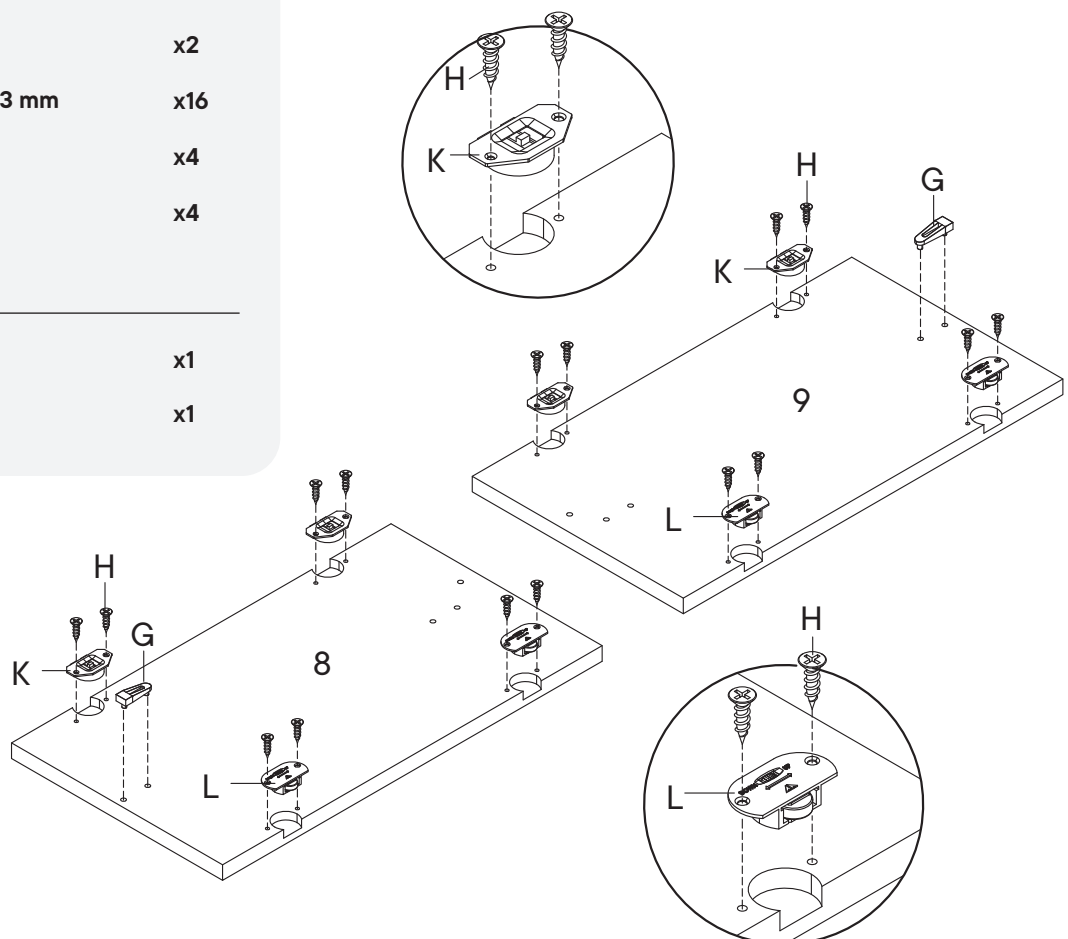

Step 7

HARDWARE

- I** Screw M 4 x 25 mm x2
- P** Handle x2

COMPONENTS

- 8** Door Right x1
- 9** Door Left x1

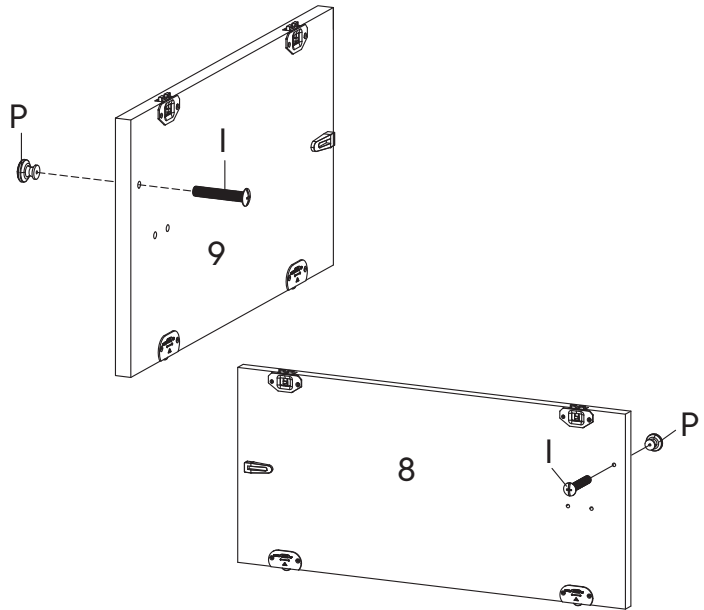

Step 8

HARDWARE

- Q** Silicon Bumper x1

COMPONENTS

- 8** Door Right x1
- 9** Door Left x1

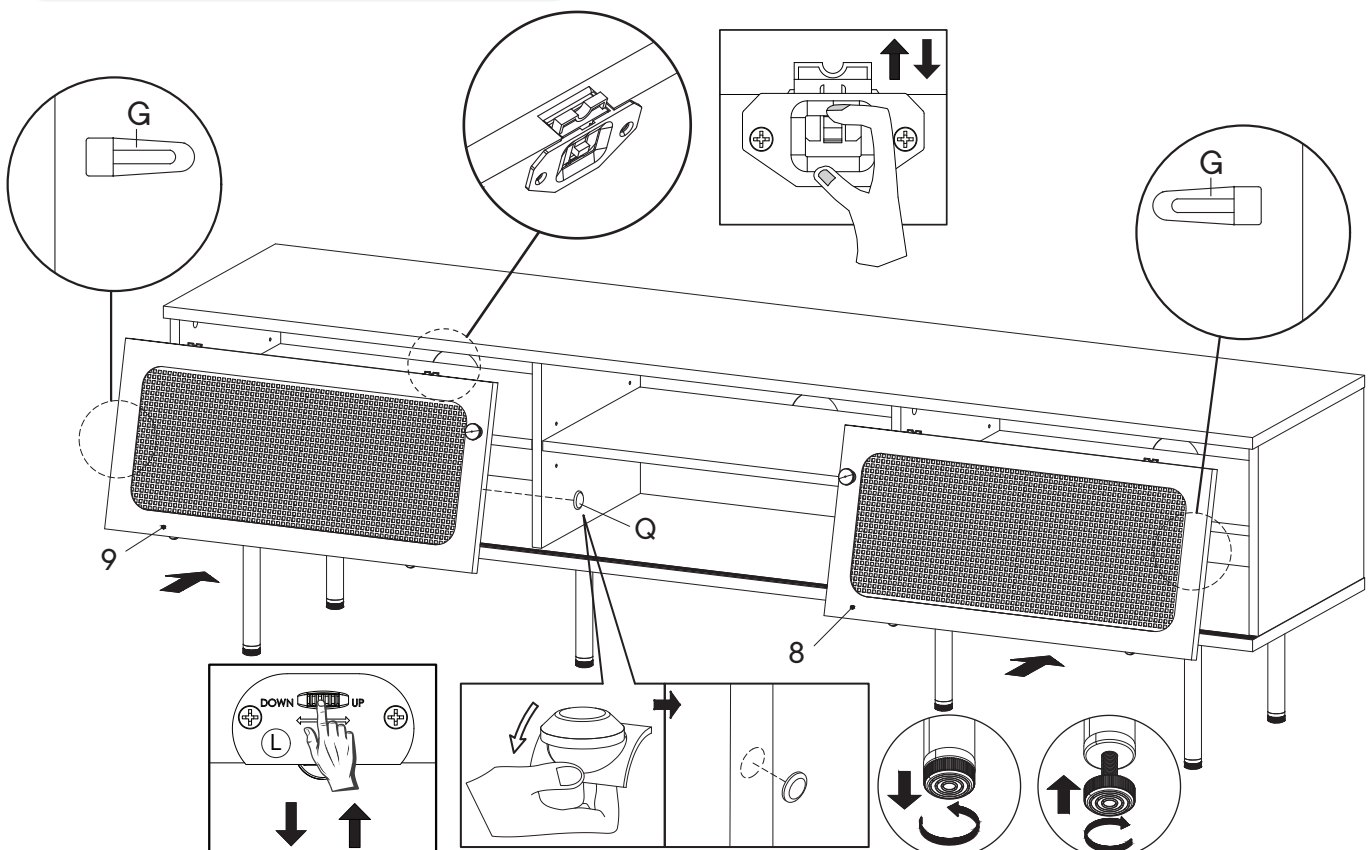

Step 9

HARDWARE

- N** Wedge x18
- O** Screw M 3.5 x 15.5 mm x18

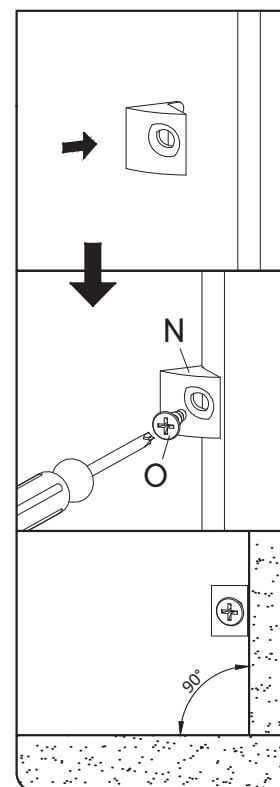
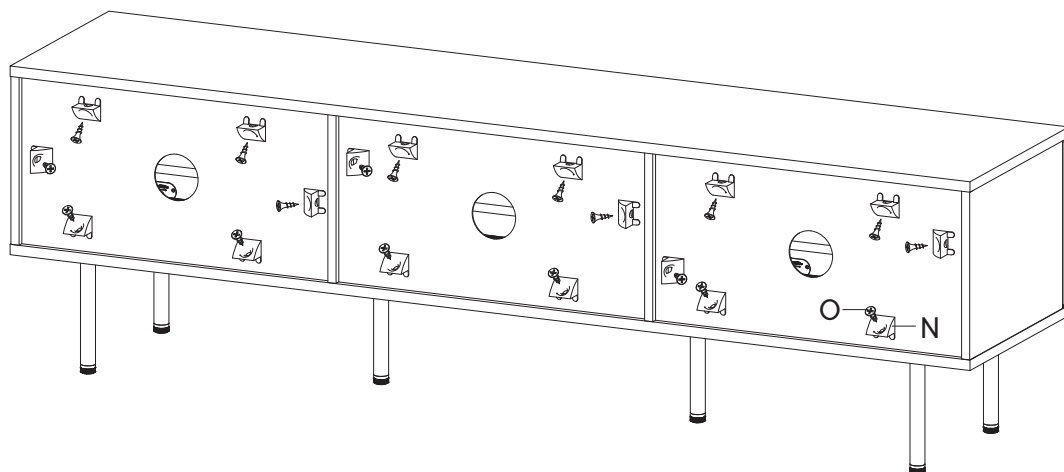

Great job!

TV Stand assembly is complete.

♥ CARING FOR YOUR ITEM

Indoor use only.

Not contract grade.

Clean using a non-abrasive cloth and a mild cleaner.

Never use harsh chemicals, as they could damage the finish or integrity of the item.

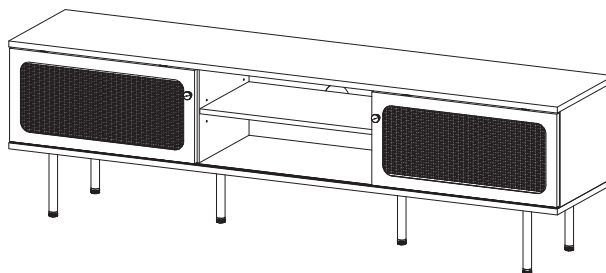

CONNECT WITH US!   

Tag us @modway_furniture and #modway for a chance to be featured.