

ASSEMBLY INSTRUCTIONS

EEI-5863

V0.09.28.21

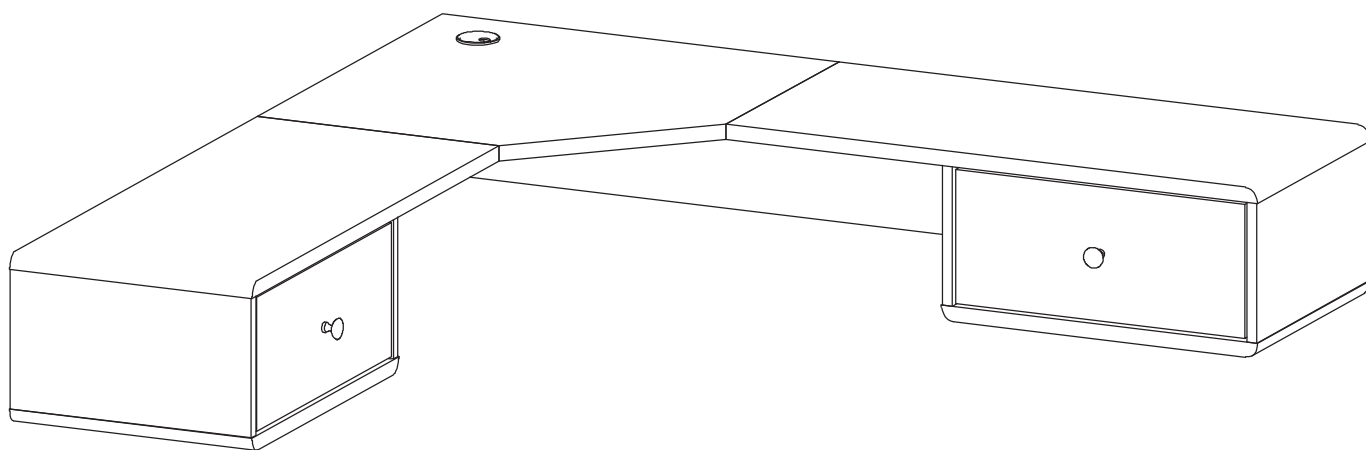

Questions? Contact us!

609.256.9000 • cs@modway.com
www.modway.com

*modway

Let's get started!

*modway



Read through all of the instructions before starting



Care instructions are listed in the last step of this manual



Approx. 120 minutes assembly time



Make sure you have all parts and components before discarding any packing materials



3 people recommended for assembly

Only use hand tools to assemble this item. Do not use power tools. Do not tighten bolts or screws completely until all hardware is lined up and inserted into the holes.

Do not over-tighten screws and bolts to avoid stripping the hardware or cracking the item.

Assemble your item on a flat, carpeted area, with plenty of space to work. This will prevent damage and scratches to your floors or the item while you're assembling the product.

Keep all components and packaging out of reach of children or animals to avoid risk of choking or suffocation.

Furniture components:

1	Top Board 1	x1	11	Side Drawer Right	x2
2	Top Board 2	x1	12	Back Drawer	x2
3	Top Board 3	x1	13	Bottom Drawer	x2
4	Bottom Board	x2	14	Back Board 1	x2
5	Side Board Left	x1	15	Back Board 2	x1
6	Side Board Right	x1	16	Back Board 3	x1
7	Center Board Left	x1			
8	Center Board Right	x1			
9	Front Drawer	x2			
10	Side Drawer Left	x2			

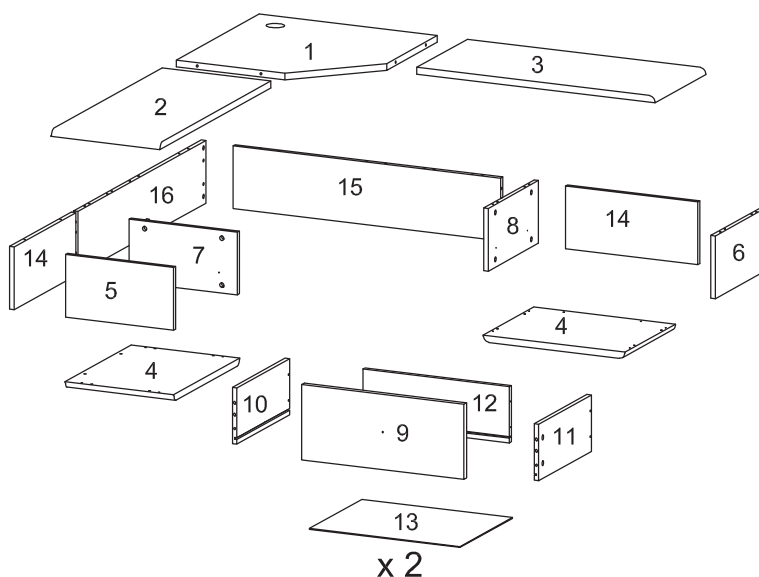

Provided hardware:

A		Cam Bolt Ø6 x 35 mm	x36	J		Screw M 8 x 39 mm	x8	S		Allen Key	x2
B		Cam Lock Ø15 mm	x28	K		Wall Plug	x18	T		Mending Plate	x4
C		Cam Lock Ø12 mm	x8	L		Screw 5.5 x 45 mm	x18	U		Handle	x2
D		Wood Dowel Ø8 x 30 mm	x38	M		Grommet Cover	x1	V		Screw M 4 x 22 mm	x2
E		Wood Dowel Ø6 x 30 mm	x4	N		Screw M 3.5 x 15.5 mm	x8	W		Wall Mounted Bolt	x2
F		Wedge	x8	O		Wood Dowel Ø10 x 50 mm	x4	RM30A		Drawer Runner	x2
G		Screw M 4.5 x 12.5 mm	x24	P		Screw M 3.5 x 13 mm	x12	PA84		Long Bracket	x2
H		JCN Nut	x16	Q		Screw M 6 x 15 mm	x16	PA39		Medium Bracket	x2
I		Screw M 6 x 10.5 mm	x8	R		Screw M 7 x 50 mm	x2	PA05		Short Bracket	x8

What you need:

Phillips Head Screwdriver

Wait!

Missing parts or hardware? Need assistance?
Contact us before returning your item. We're here to help!
609.256.9000 • cs@modway.com

Step 1

HARDWARE

- A** Cam Bolt Ø6 x 35 mm x8
- E** Wood Dowel Ø6 x 30 mm x4

COMPONENTS

- 9** Front Drawer x2
- 10** Side Drawer Left x2
- 11** Side Drawer Right x2

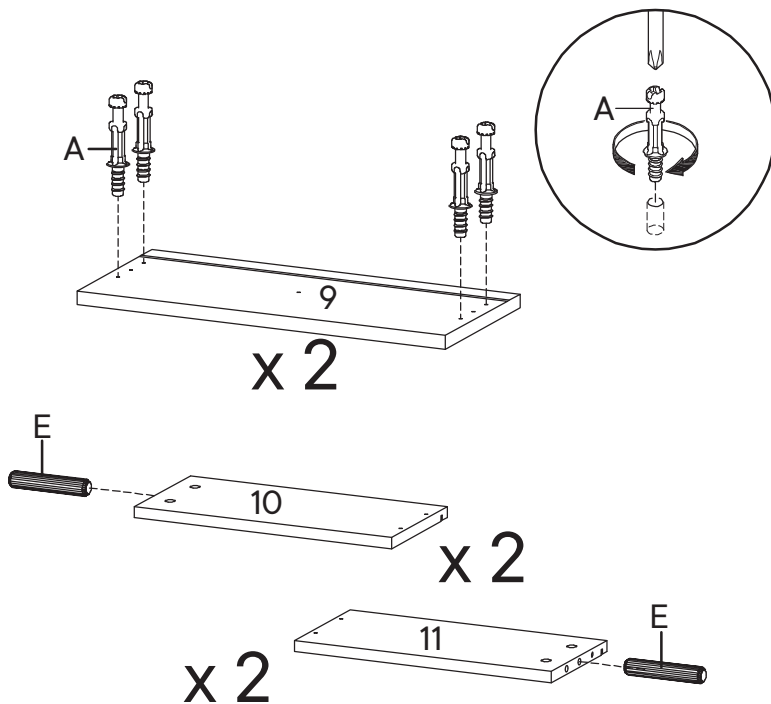

Step 2

HARDWARE

- C** Cam Lock Ø12 mm x8
- J** Screw M 8 x 39 mm x8

COMPONENTS

- 9** Front Drawer x2
- 10** Side Drawer Left x2
- 11** Side Drawer Right x2
- 12** Back Drawer x2
- 13** Bottom Drawer x2

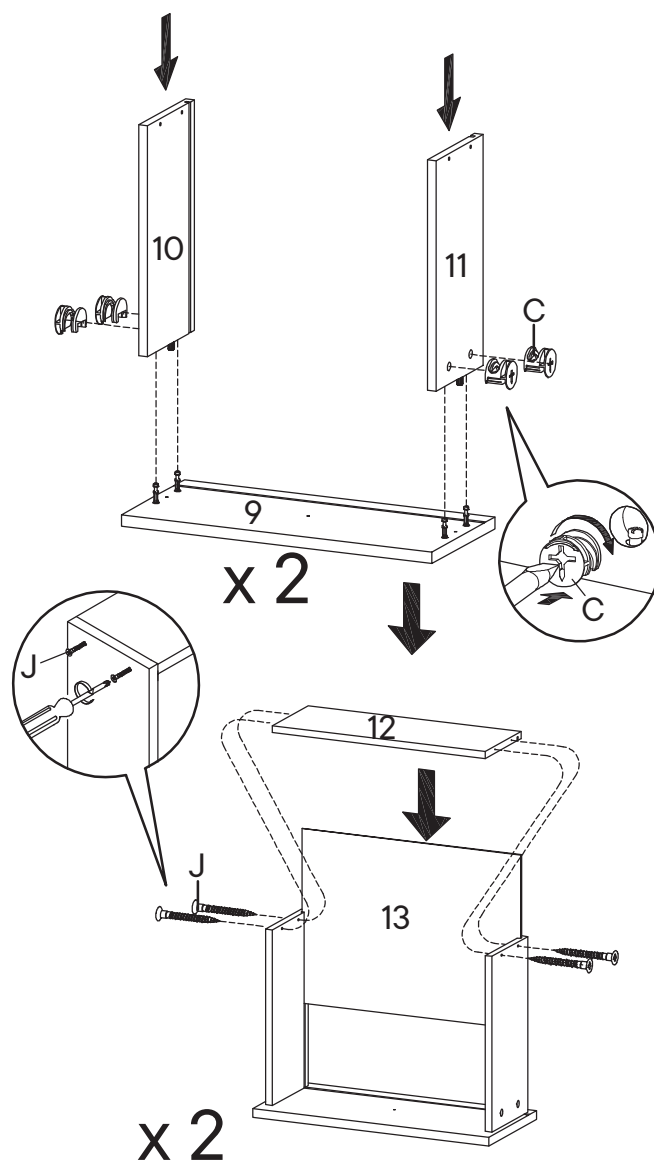

Step 3

HARDWARE

F	Wedge	x8
N	Screw M 3.5 x 15.5 mm	x8
P	Screw M 3.5 x 13 mm	x12
U	Handle	x2
V	Screw M 4 x 22 mm	x2
RM30A	Drawer Runner	x2

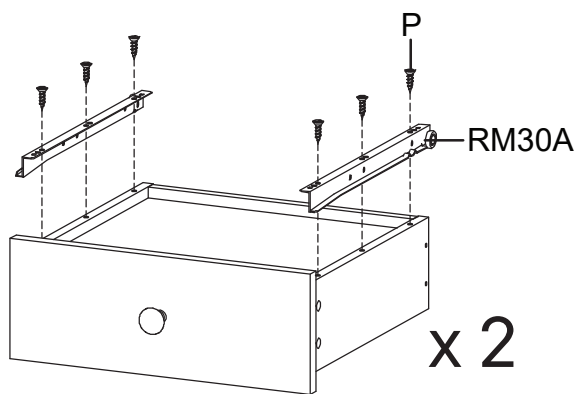
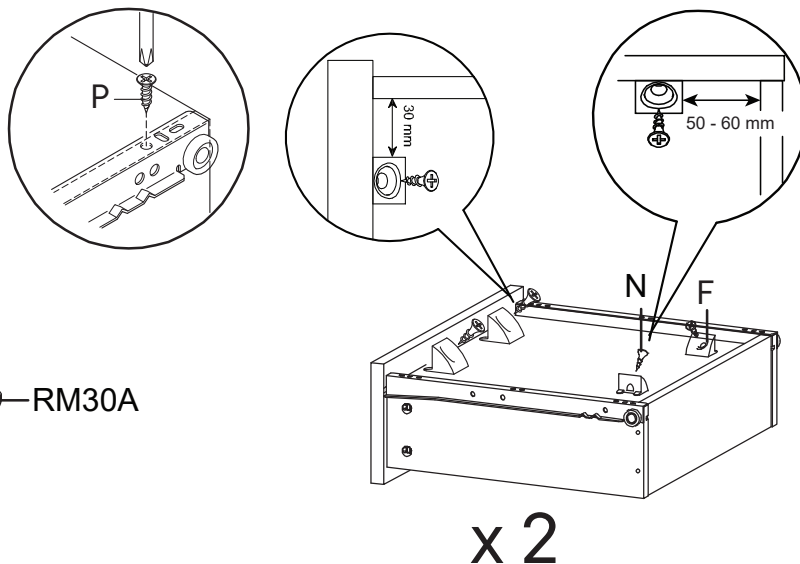
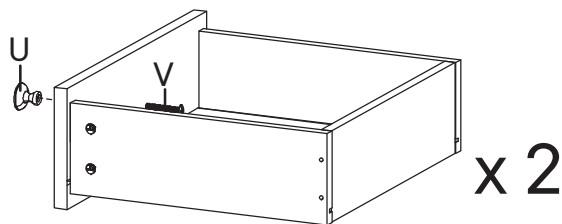

Step 4

HARDWARE

D	Wood Dowel Ø8 x 30 mm	x14
O	Wood Dowel Ø10 x 50 mm	x4

COMPONENTS

1	Top Board 1	x1
15	Back Board 2	x1
16	Back Board 3	x1

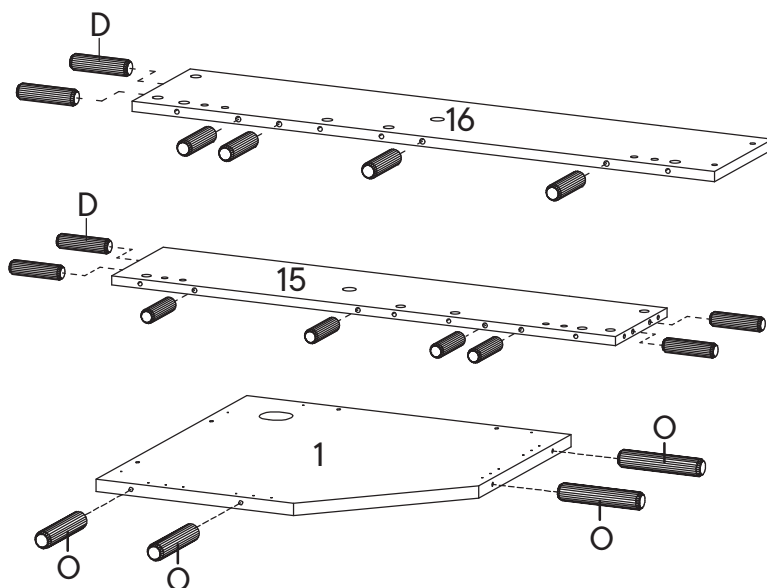

Step 5

HARDWARE

- A** Cam Bolt Ø6 x 35 mm x4
- D** Wood Dowel Ø8 x 30 mm x8
- I** Screw M 6 x 10.5 mm x4
- RM30A** Drawer Runner x1

COMPONENTS

- 7** Center Board Left x1
- 8** Center Board Right x1

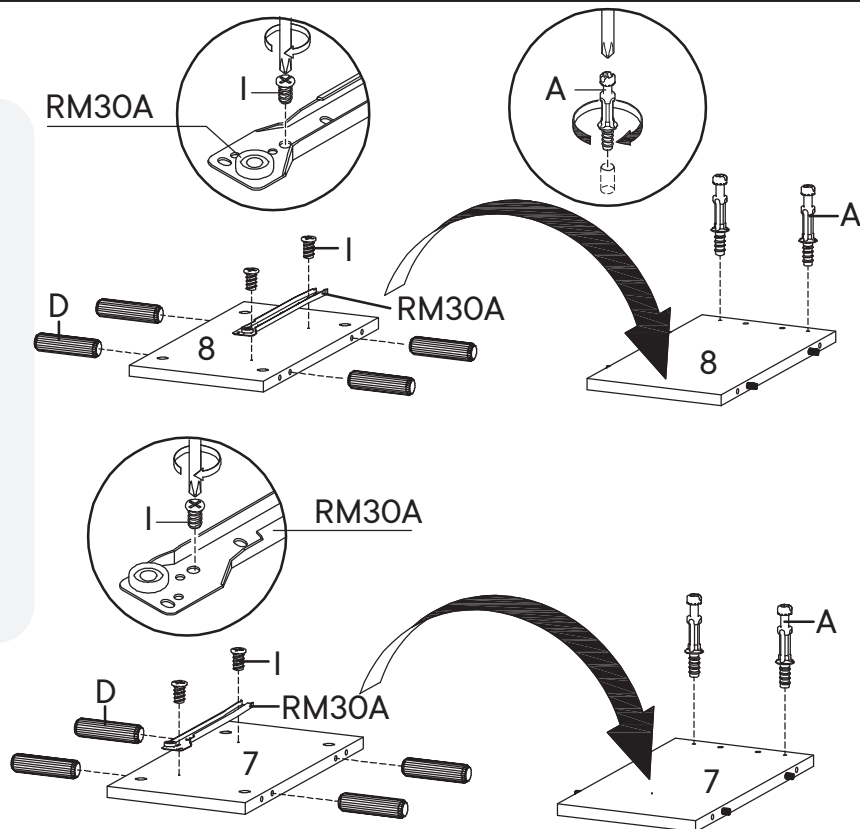

Step 6

HARDWARE

- D** Wood Dowel Ø8 x 30 mm x16
- I** Screw M 6 x 10.5 mm x4
- RM30A** Drawer Runner x1

COMPONENTS

- 5** Side Board Left x1
- 6** Side Board Right x1
- 14** Back Board 1 x2

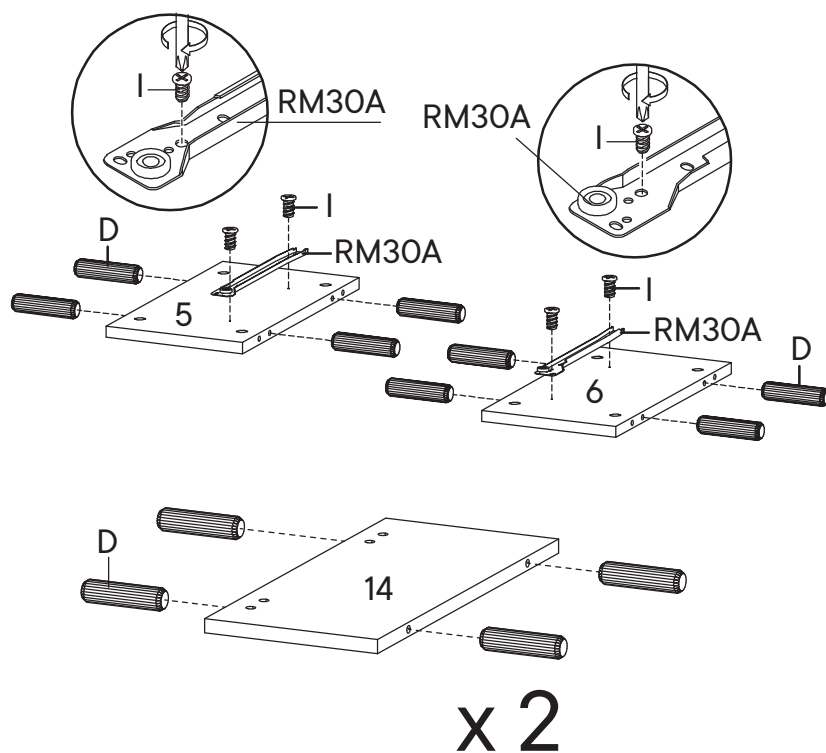

Step 7

HARDWARE

A Cam Bolt Ø6 x 35 mm x8

COMPONENTS

4 Bottom Board x2

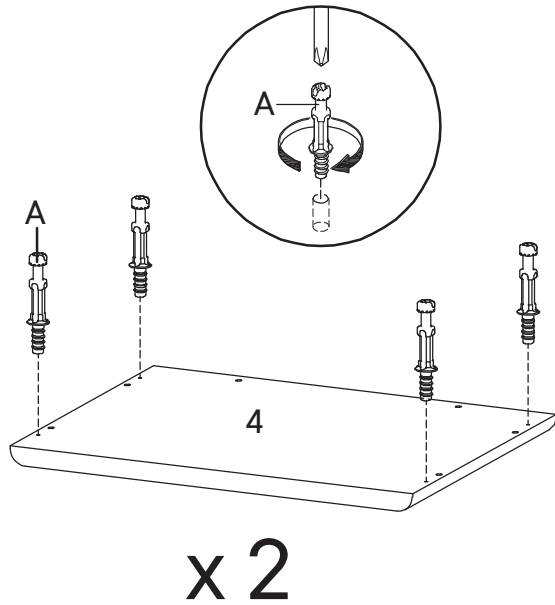

Step 8

HARDWARE

R Screw M 7 x 50 mm x2

S Allen Key x1

COMPONENTS

15 Back Board 2 x1

16 Back Board 3 x1

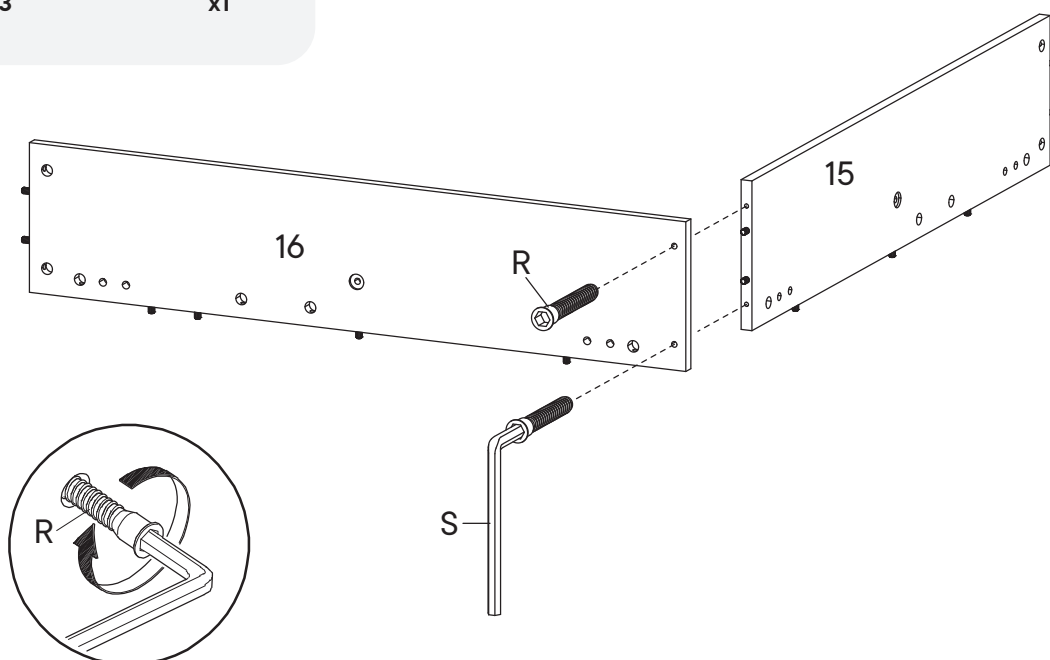

Step 9

HARDWARE

B Cam Lock Ø15 mm x4

COMPONENTS

7 Center Board Left x1

8 Center Board Right x1

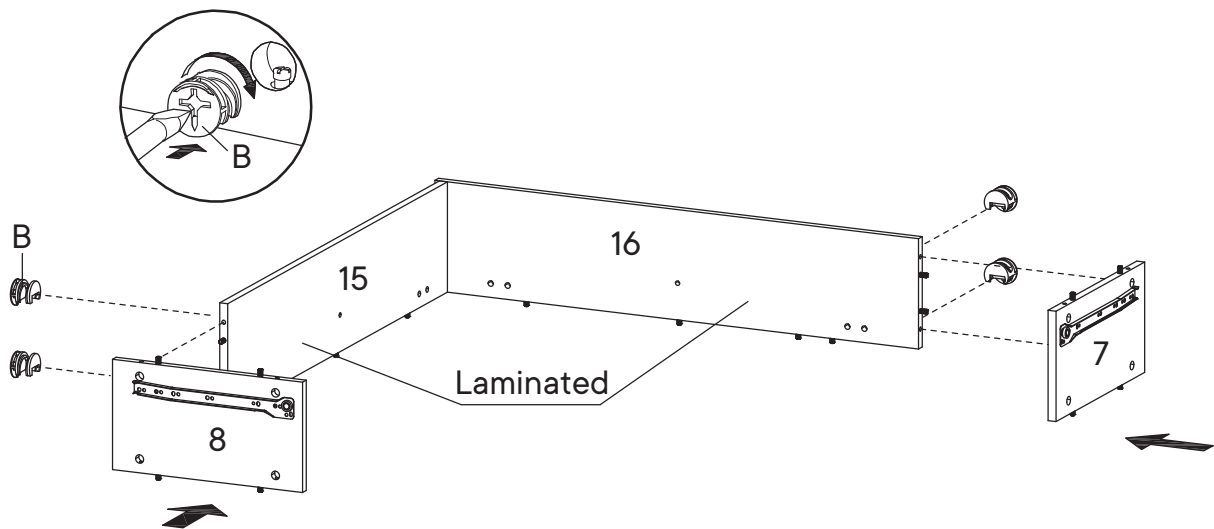

Step 10

COMPONENTS

1 Top Board 1 x1

2 Top Board 2 x1

3 Top Board 3 x1

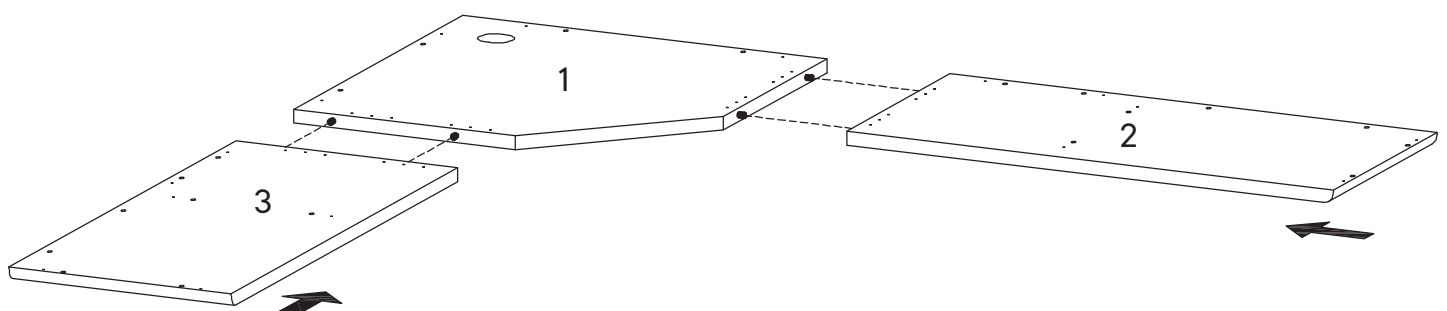

Step 11

HARDWARE

- G** Screw M 4.5 x 12.5 mm x24
- T** Mending Plate x4

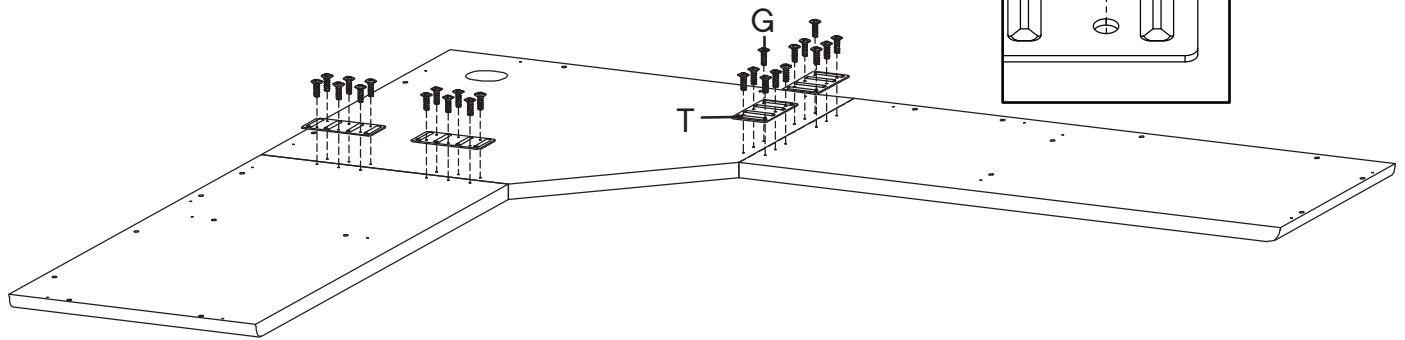

Step 12

HARDWARE

- A** Cam Bolt $\varnothing 6$ x 35 mm x16

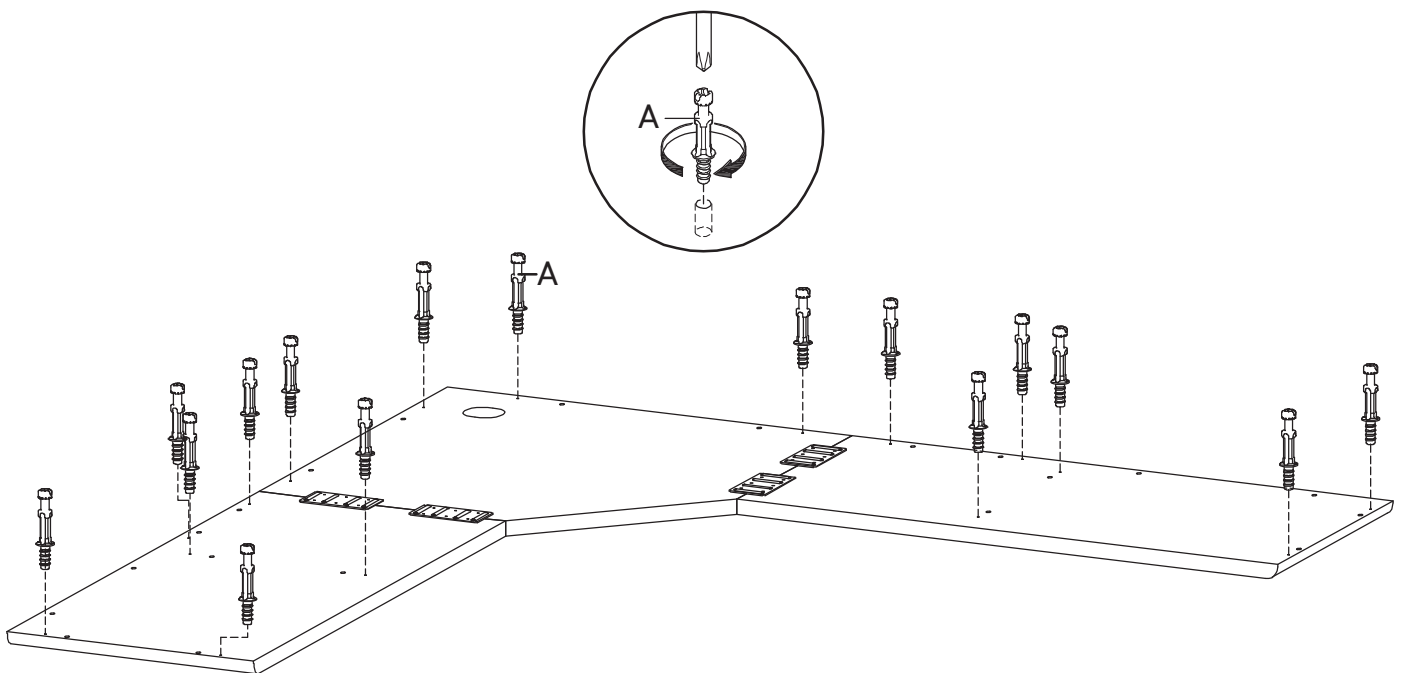

Step 13

HARDWARE

B Cam Lock Ø15 mm x12

COMPONENTS

7 Center Board Left x1

8 Center Board Right x1

15 Back Board 2 x1

16 Back Board 3 x1

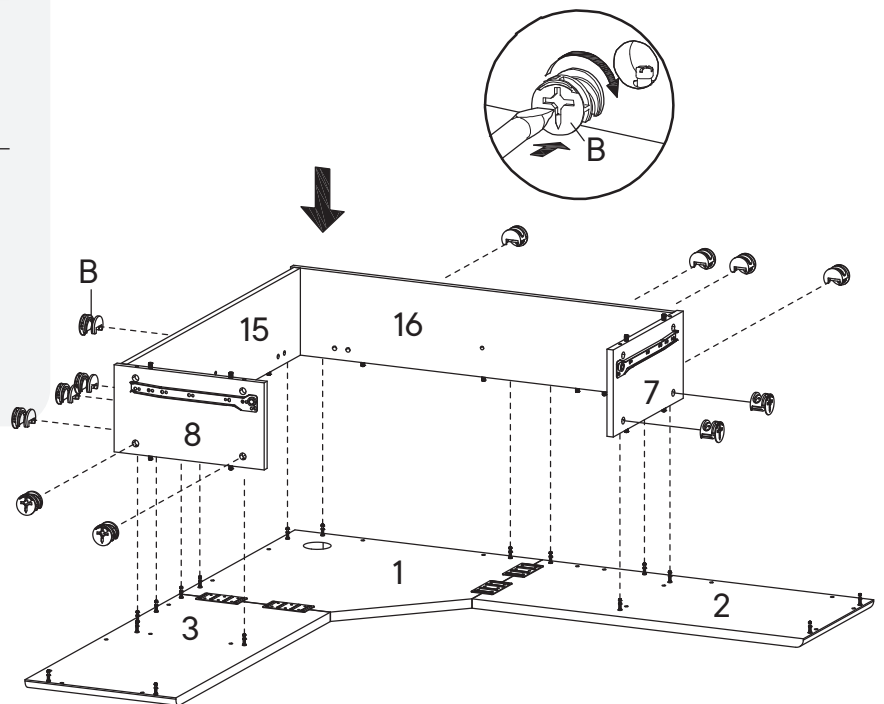

Step 14

COMPONENTS

14 Back Board 1 x2

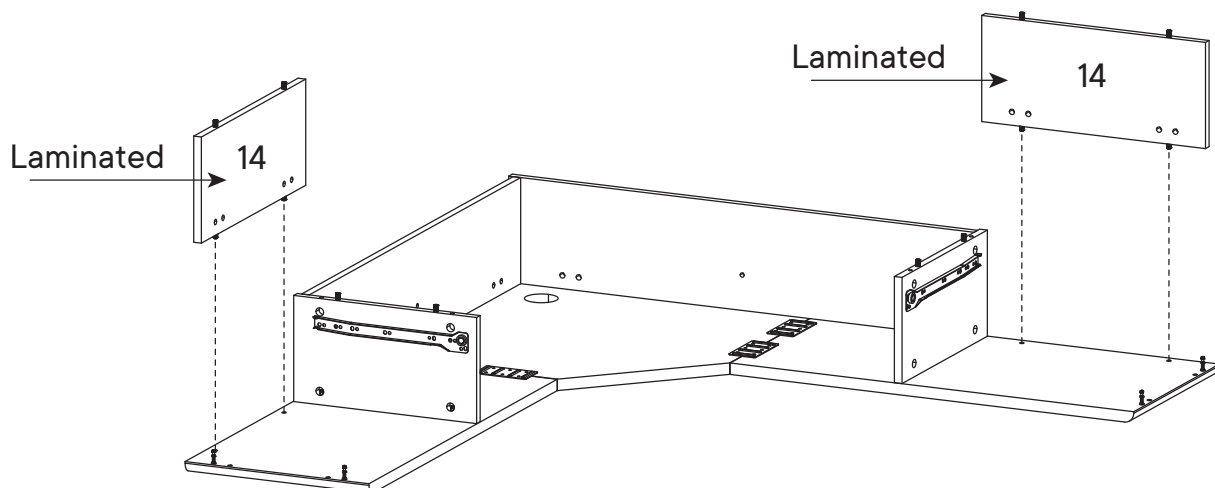

Step 15

HARDWARE

B Cam Lock Ø15 mm x4

COMPONENTS

5 Side Board Left x1

6 Side Board Right x1

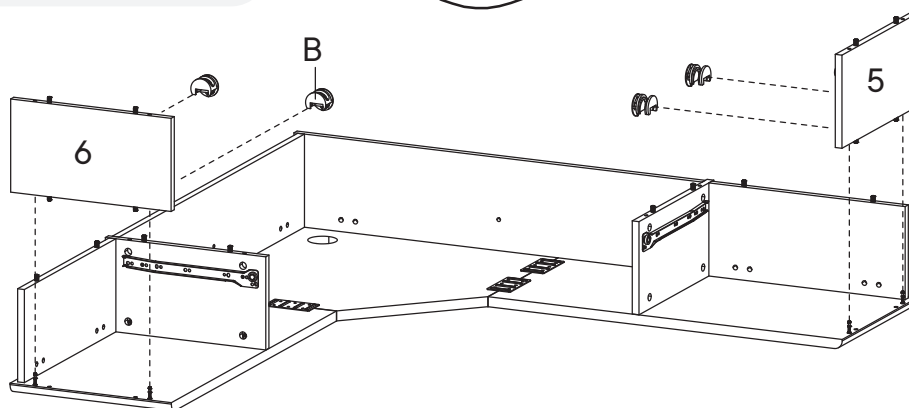
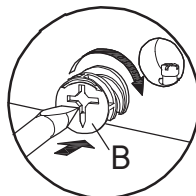

Step 16

HARDWARE

H JCN Nut x16

Q Screw M 6 x 15 mm x16

S Allen Key x2

PA05 Short Bracket x8

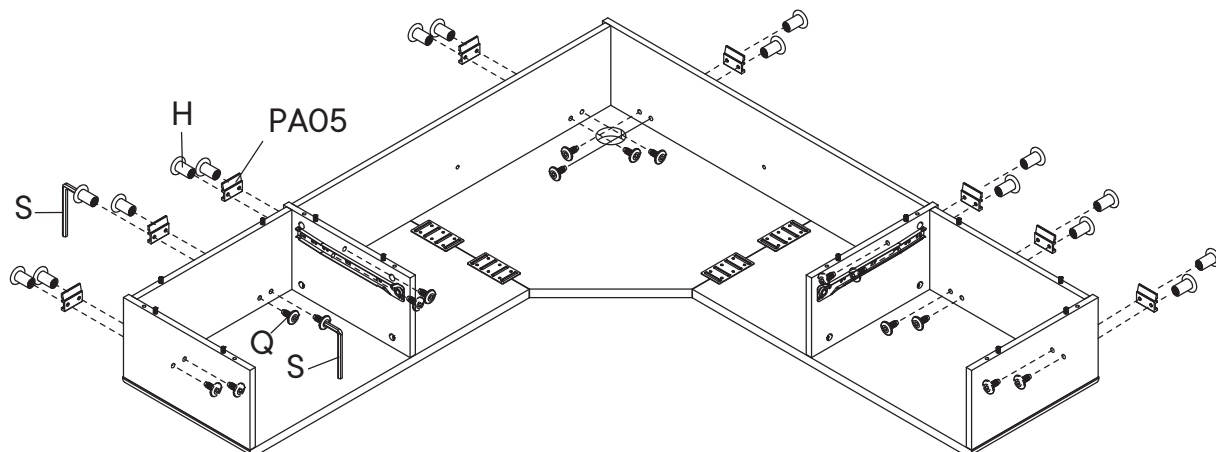
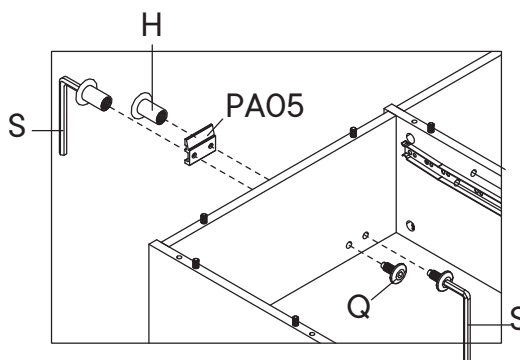

Step 17

HARDWARE

B Cam Lock $\varnothing 15$ mm x8

COMPONENTS

4 Bottom Board x2

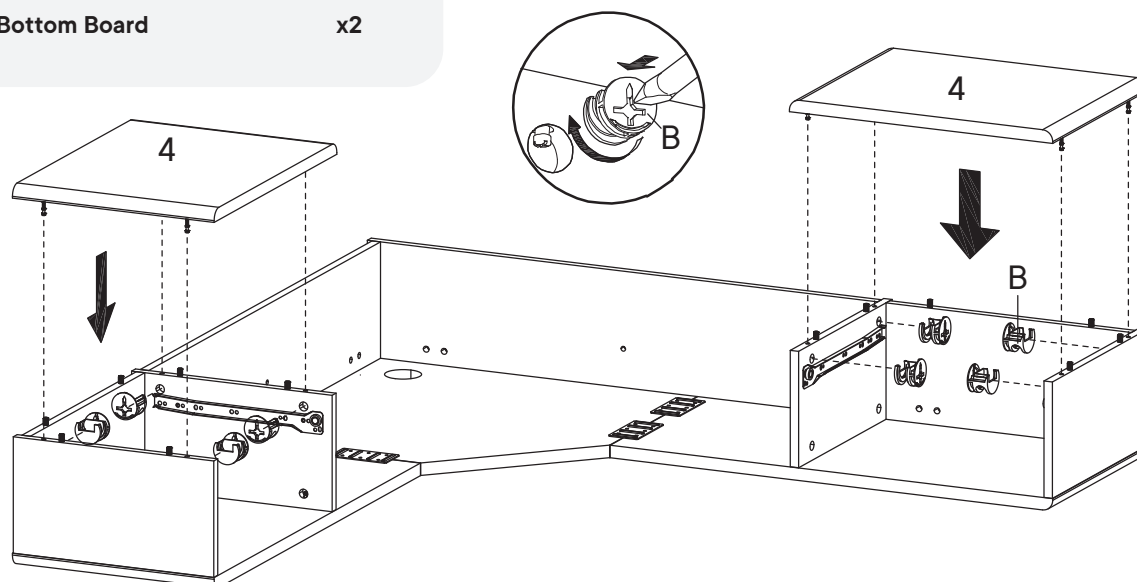

Step 18

Determine your desired (Y) height (760mm recommended), then subtract by 88 mm. This is the drill holes height from the floor (Z).

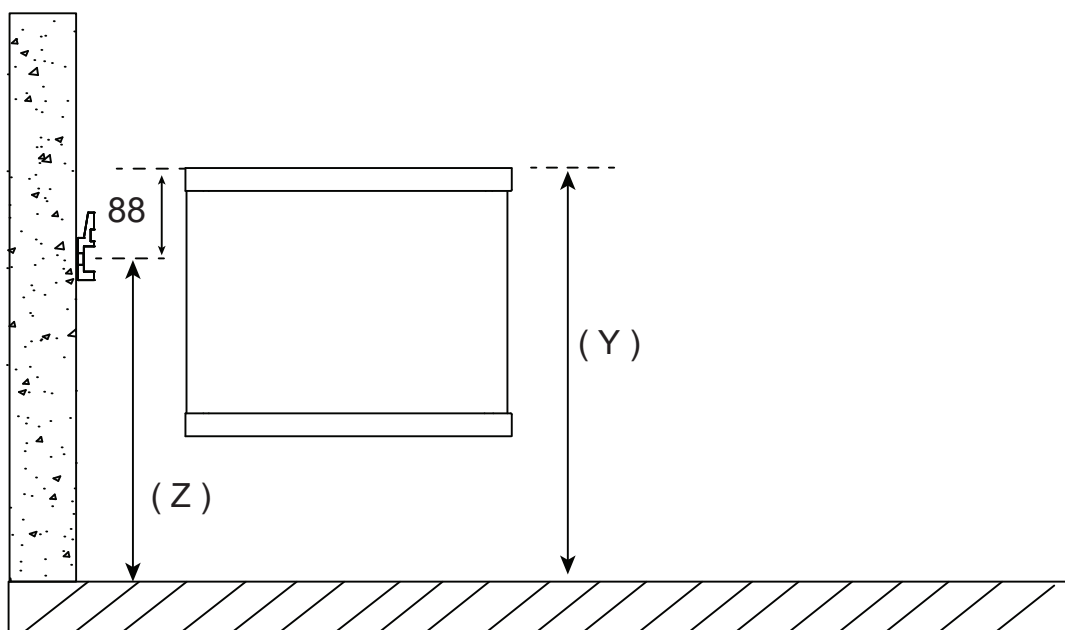

Step 19

Please use minimum 2 holes on Medium Bracket and Long Bracket, and minimum 1 hole, to apply the wall plug and screw. Use additional holes when necessary.

* Long Bracket and Medium Bracket

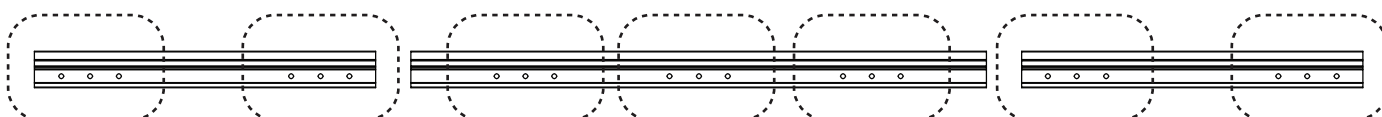

Different wall materials require unique wall fasteners.

The wall plugs (K) and screws (L) are designed for fixing to concrete walls only.

Please consult your local hardware store to ensure you are using the correct hardware for your wall type.

Step 20

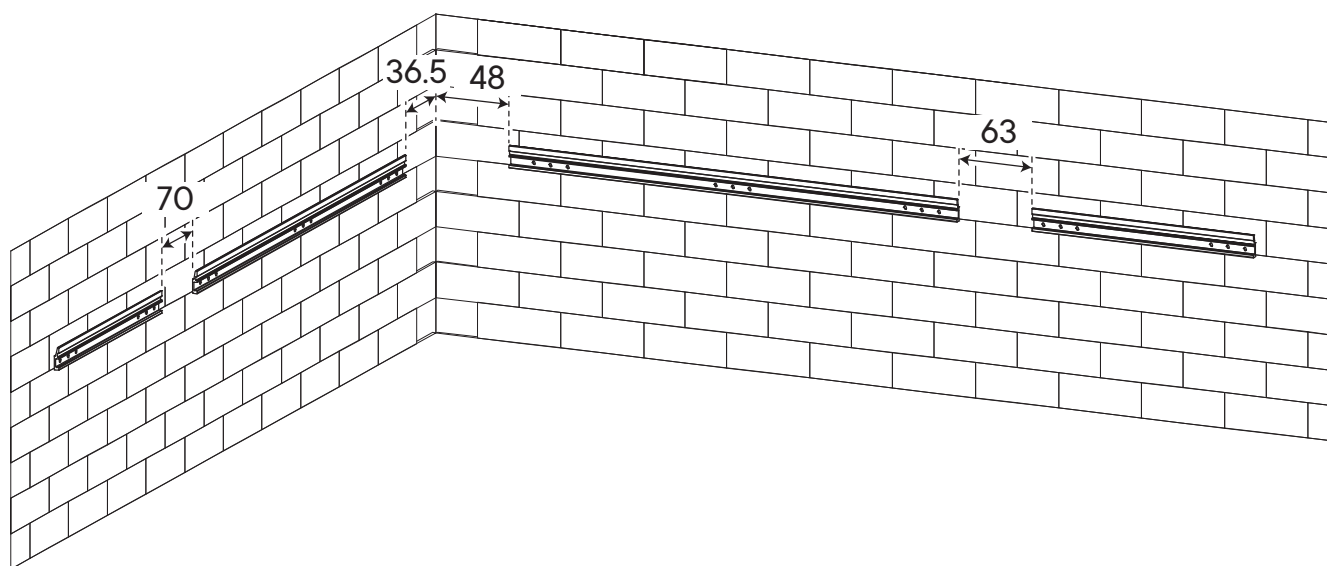

Step 21

HARDWARE

- K** Wall Plug x14
- L** Screw 5.5 x 45 mm x14
- PA84** Long Bracket x2
- PA39** Medium Bracket x2

Use Waterpass to ensure the drill position

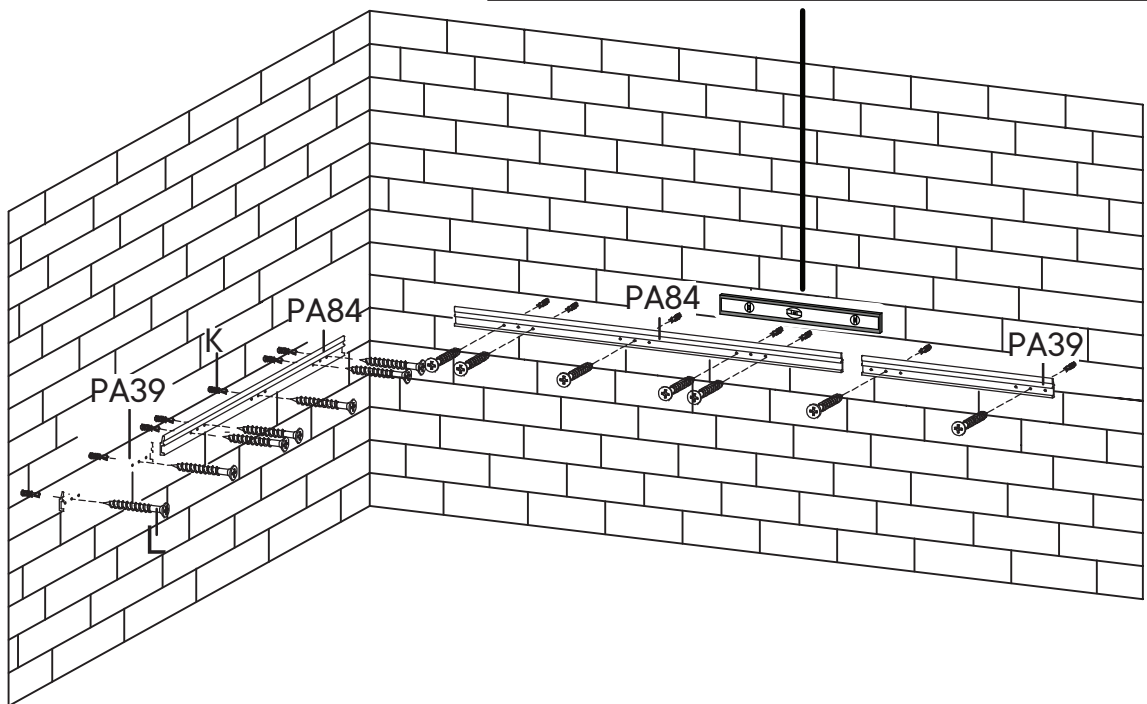

Step 22

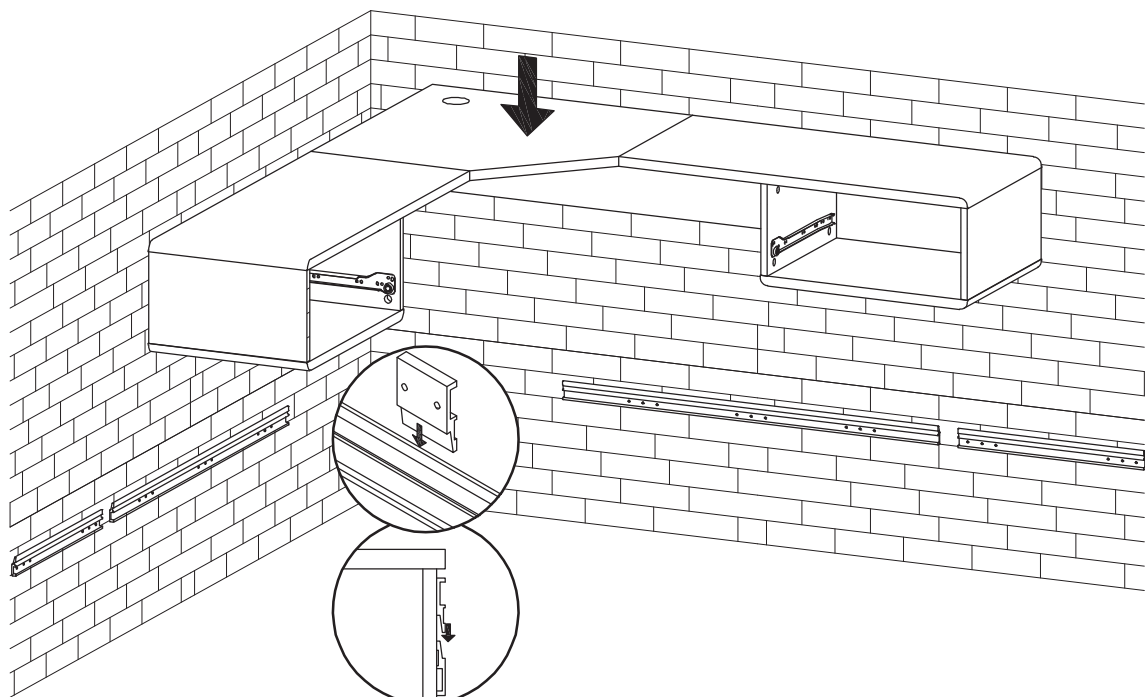

Step 23

HARDWARE

W Wall Mounted Bolt x2

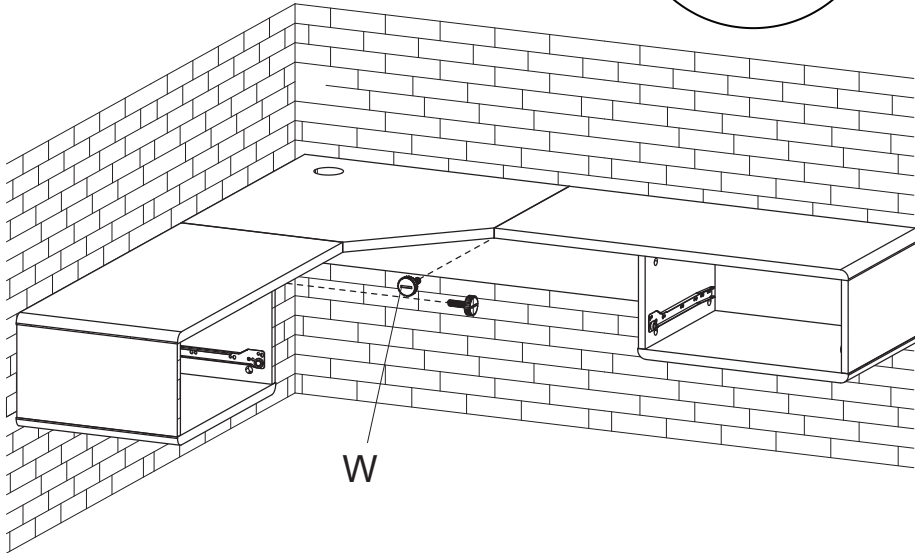
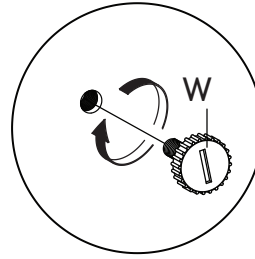

Step 24

HARDWARE

M Grommet Cover x1

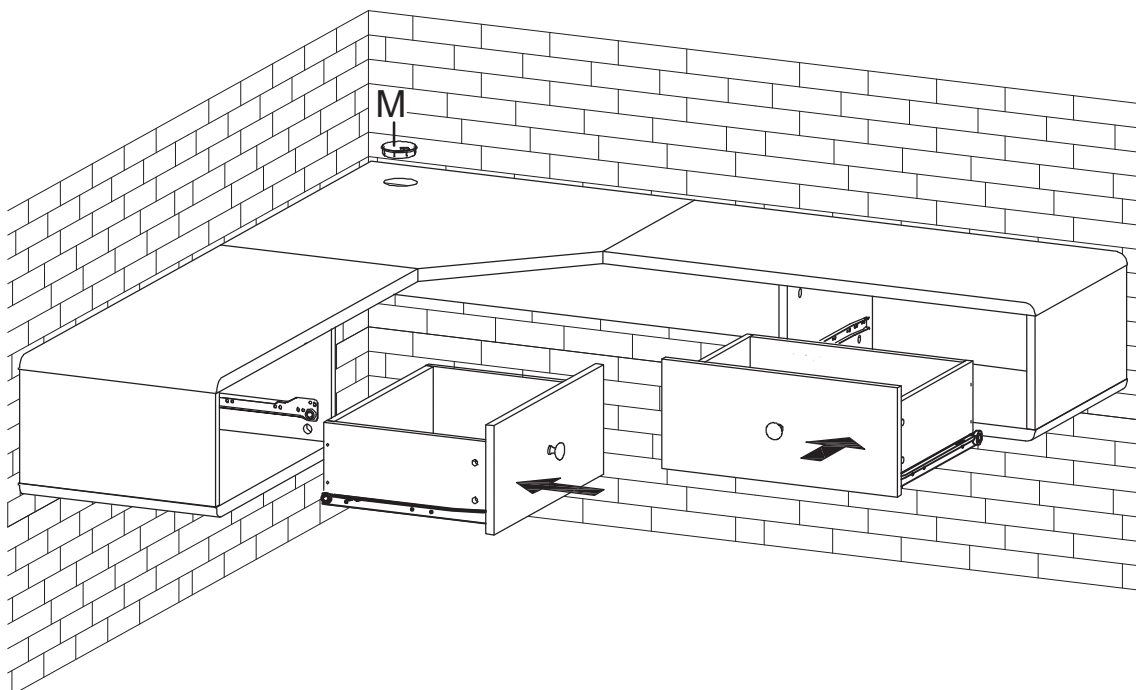
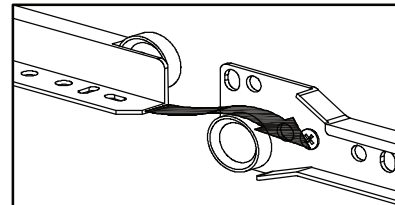

Great job!

Desk assembly is complete.

♥ CARING FOR YOUR ITEM

Indoor use only.

Not contract grade.

Clean using a non-abrasive cloth and a mild cleaner.

Never use harsh chemicals, as they could damage the finish or integrity of the item.

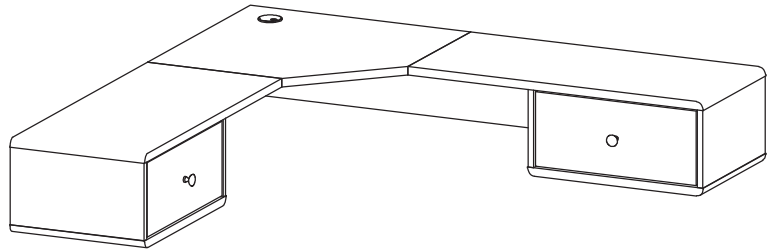

CONNECT WITH US!   

Tag us @modway_furniture and #modway for a chance to be featured.