

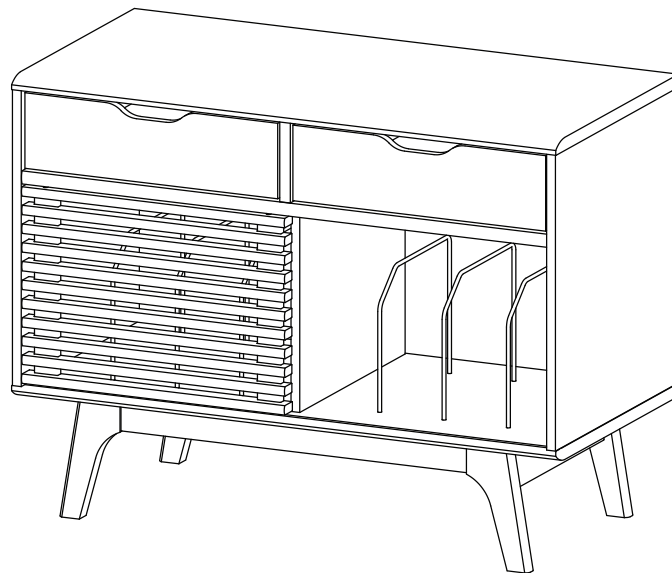









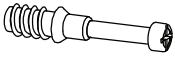

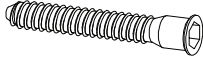



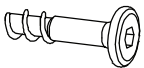

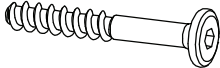

Thank you for purchasing the **MODWAY CABINET** !

Before you start, here are some helpful advice:

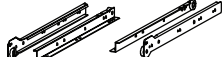
1. We suggest you spend a short time reading through this leaflet and then follow the simple step-by-step instructions.
2. Owing to the size and weight of the Cabinet, we recommend that it is assembled by two adults, on a carpeted or padded area, in the room that it is intended for. Approximate assembly time: 60 minutes.
3. Please do not use any tools other than those provided or recommended in these instructions.
4. Please do not throw away any of the packaging or instructions until you have checked all the components and hardware and the furniture is fully assembled.
5. Assemble all components loosely until advised to tighten. Depending on use, it may be necessary to tighten the components from time to time, so please save the tools that have been provided.
6. Please keep all pieces out of reach of children.

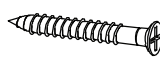

Hardware :

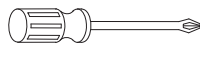
A) Cambolt/Metal  \varnothing 6 x 35 mm x 18	B) CamLock Big/Metal  \varnothing 15 mm x 14	C) Dowel/Wood  \varnothing 8 x 30 mm x 36	D) Screw/Metal  M 7 x 50 mm x 6	E) Hex /Allen Key/Metal  L 4 x 1
F) Wedge/Plastic  9 x 14 x 10 mm x 16	G) Screw/Metal  M 3.5 x 15.5 mm x 16	H) Screw/Metal  M 6.4 x 25 mm x 4	I) Pin Sliding Top/Plastic  \varnothing 8 x 19 mm x 2	J) Pin Sliding Bottom/Plastic  \varnothing 8 x 16 mm x 2
K) Bumper /Silicon  \varnothing 8 mm x 2	L) Screw/Metal  M 6.4 x 53 mm x 4	M) Divider wire/Metal  x 6	N) Dowel/Wood  \varnothing 8 x 50 mm x 2	O) Dowel/Wood  \varnothing 6 x 30 mm x 4
P) CamLock Small/Metal  \varnothing 12 mm x 4	Q) Rail/Metal  350 mm x 2	R) Screw/Metal  M 6 x 10.5 mm x 8	S) Screw/Metal  M 8 x 39 mm x 8	T) Screw/Metal  M 3.5 x 13 mm x 12
U) Screw Cap/Plastic  \varnothing 15 mm x 1	V) Floor Protector/Sponge/Felt  25 x 25 x 2 mm x 4	W) Screwdriver (Not Include)  x 1		

Components:

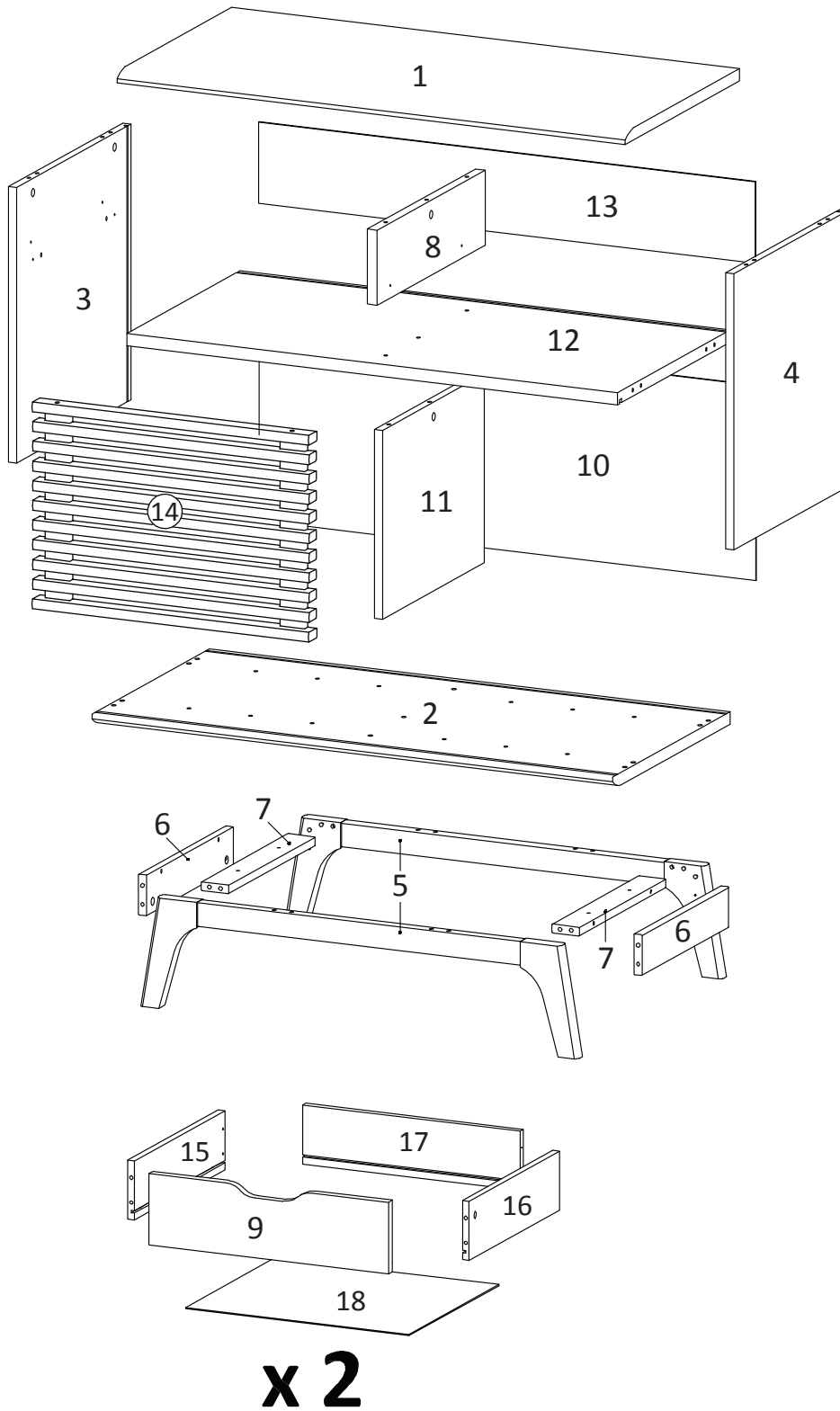

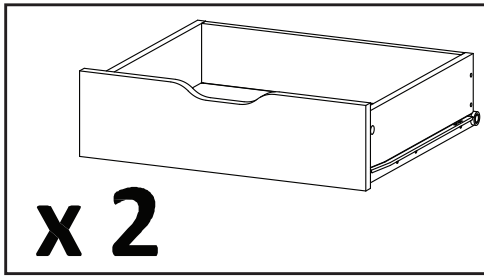

1	Top Board	x1	2	Bottom Board	x1	3	Side Board Left	x1	4	Side Board Right	x1
5	Assembly Leg	x2	6	Support Board 1	x2	7	Support Board 2	x2	8	Center Board 1	x1
9	Front Drawer	x2	10	Back Board 1	x1	11	Center Board 2	x1	12	Fixed Shelf	x1
13	Back Board 2	x1	14	Frame Door	x1	15	Side Drawer Left	x2	16	Side Drawer Right	x2
17	Back Drawer	x2	18	Bottom Drawer	x2						

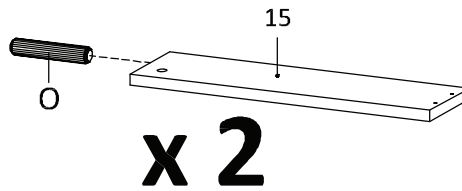
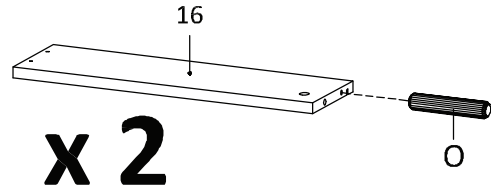
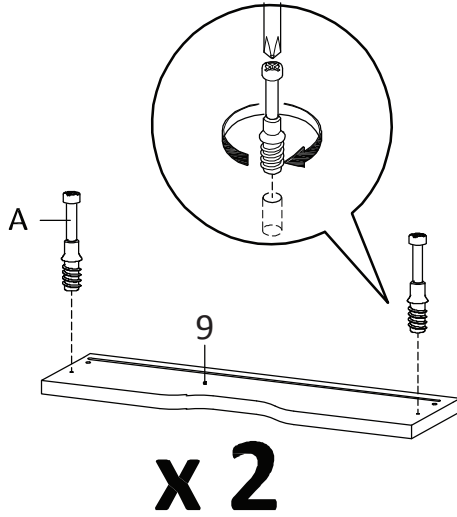

STEP 1:

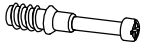



		
Ax4	Ox4	Wx1

Hardware required.
Screwdriver not included

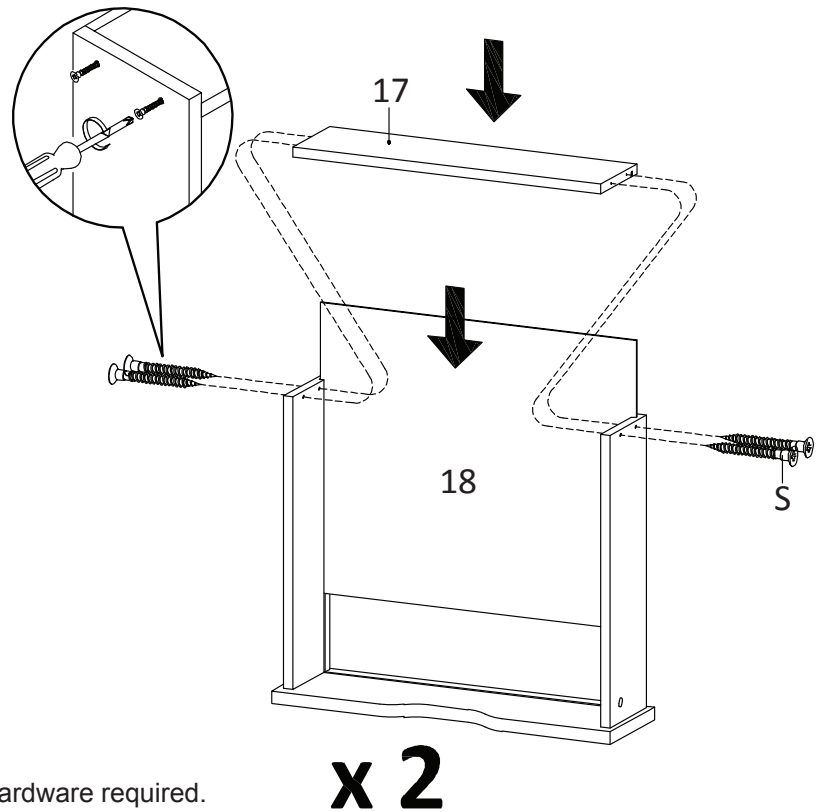
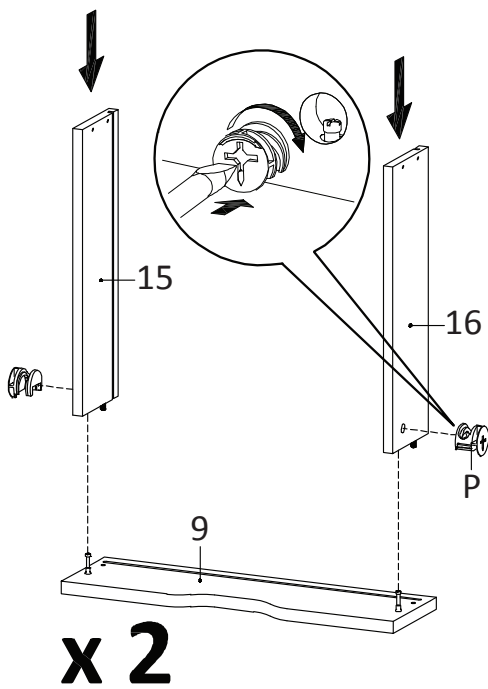
STEP 2:



		
Px4	Sx8	Wx1

Hardware required.
Screwdriver not included

STEP 3:

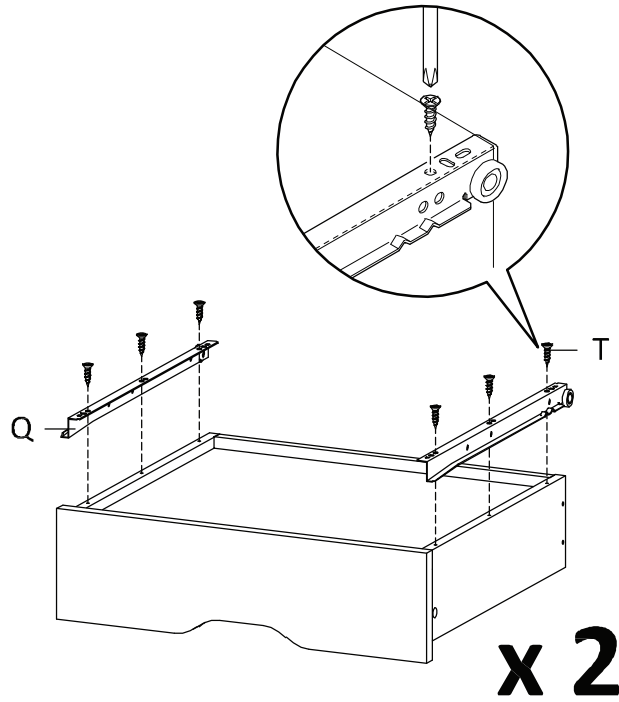

Qx2	Tx12	Wx1

Hardware required.
Screwdriver not included

STEP 4:

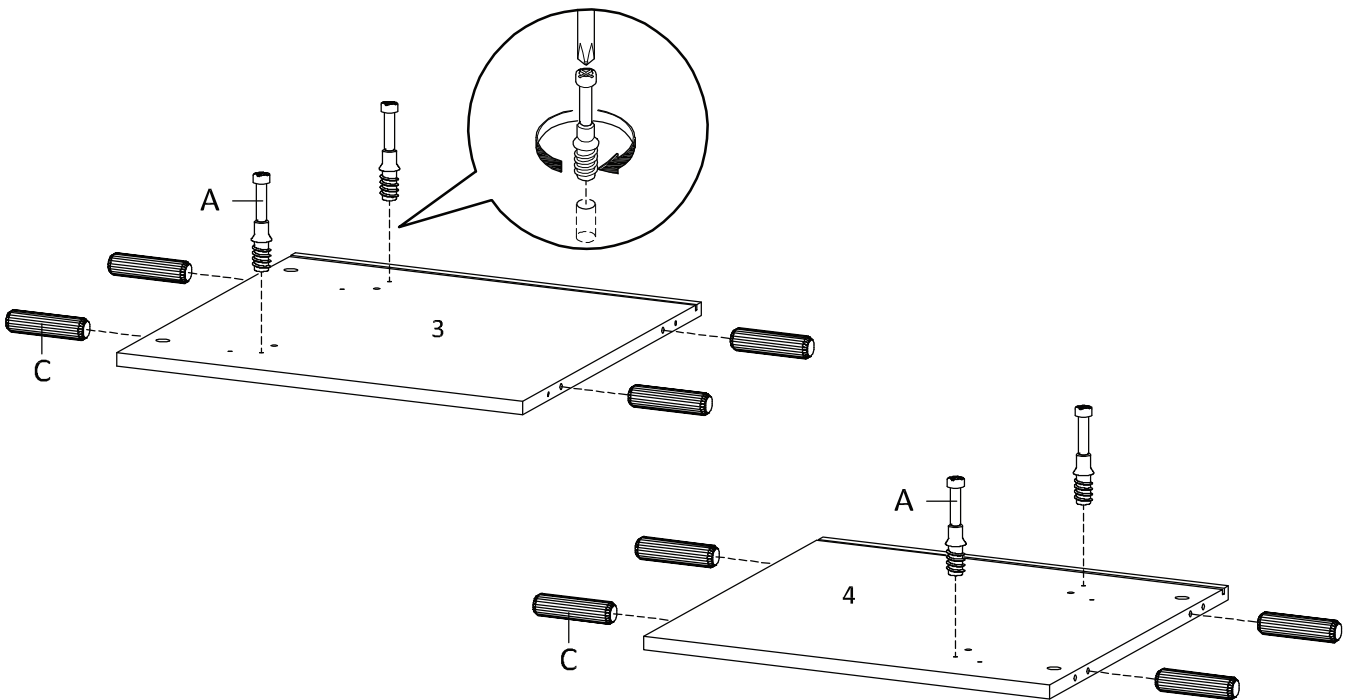

Ax4	Cx8	Wx1

Hardware required.
Screwdriver not included

STEP 5: Drawer runner/rail track assembly to side-board (3 & 4)

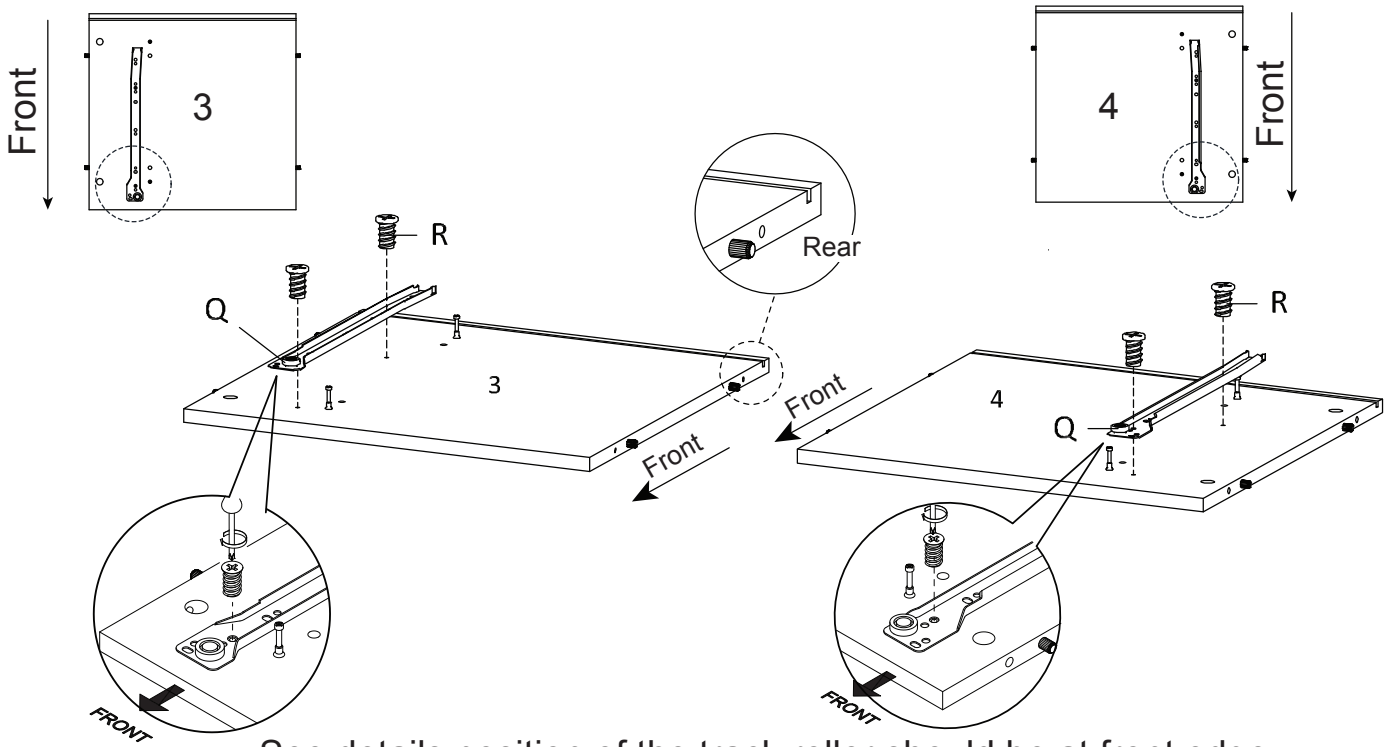

Qx1	Rx4	Wx1

Hardware required.
Screwdriver not included

STEP 6:

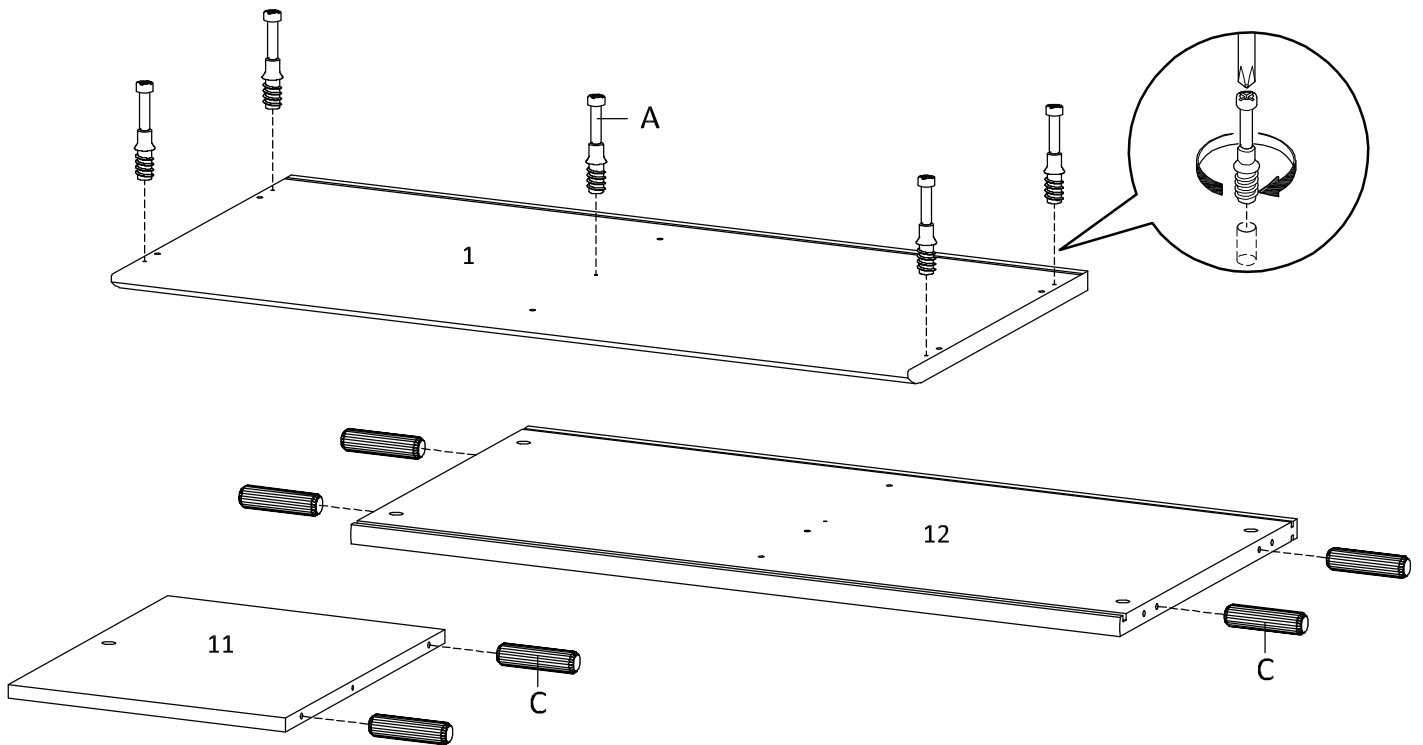

Ax5	Cx6	Wx1

Hardware required.
Screwdriver not included

STEP 7: Drawer runner/rail track assembly to center-board (8)

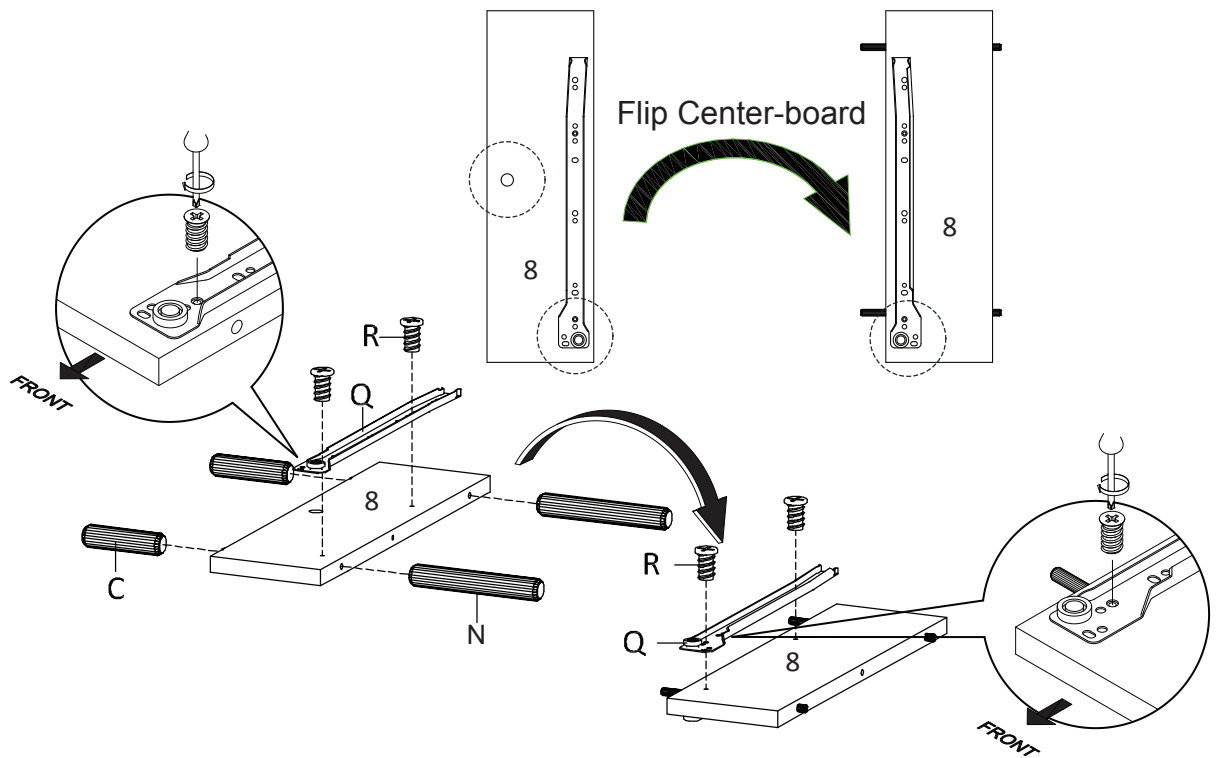

Cx2	Nx2	Qx1	Rx4	Wx1

Hardware required.
Screwdriver not included

STEP 8: Securing the Center Board (8) to Fixed Shelf (12)

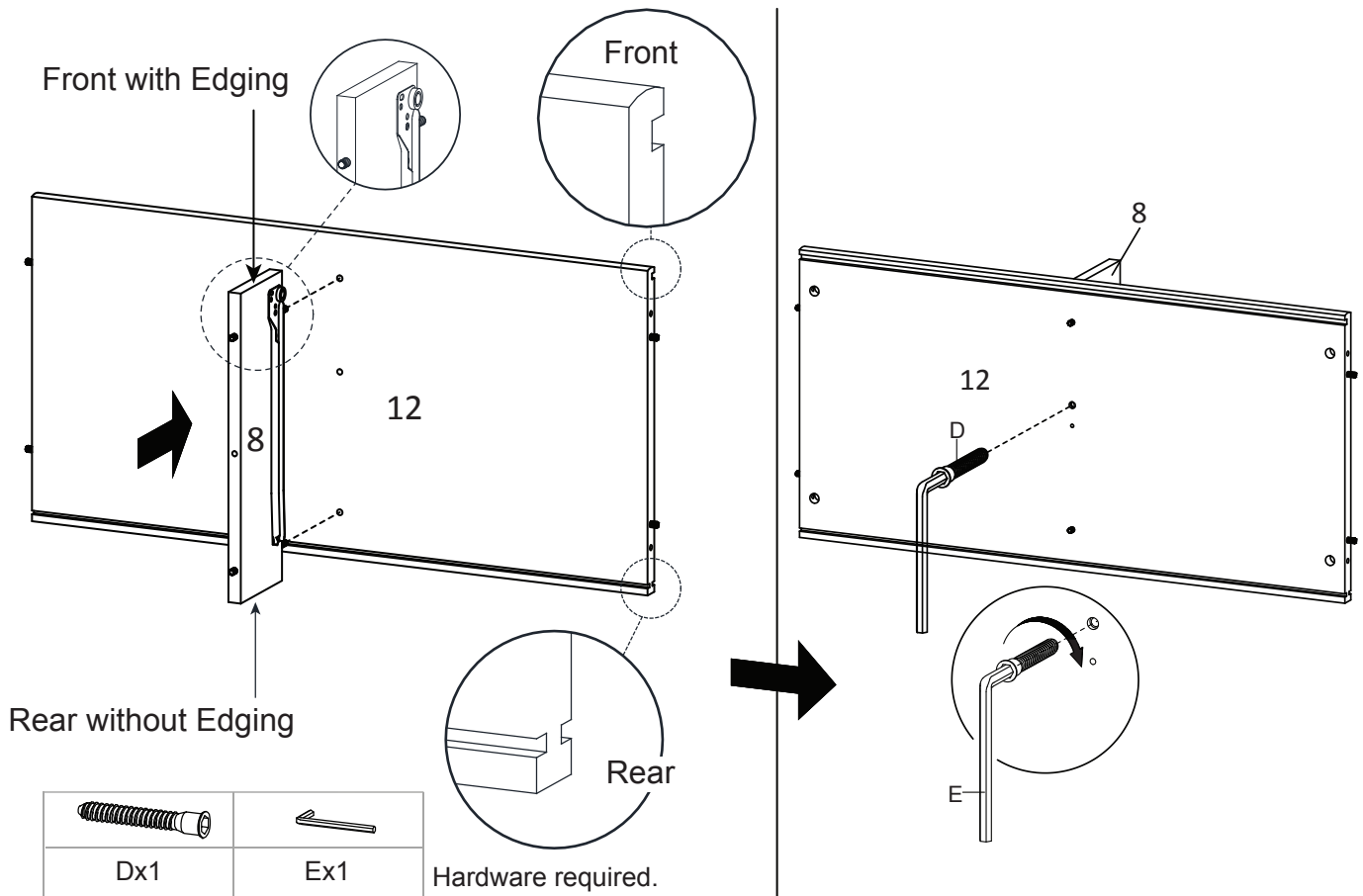

Dx1	Ex1

Hardware required.

STEP 9:

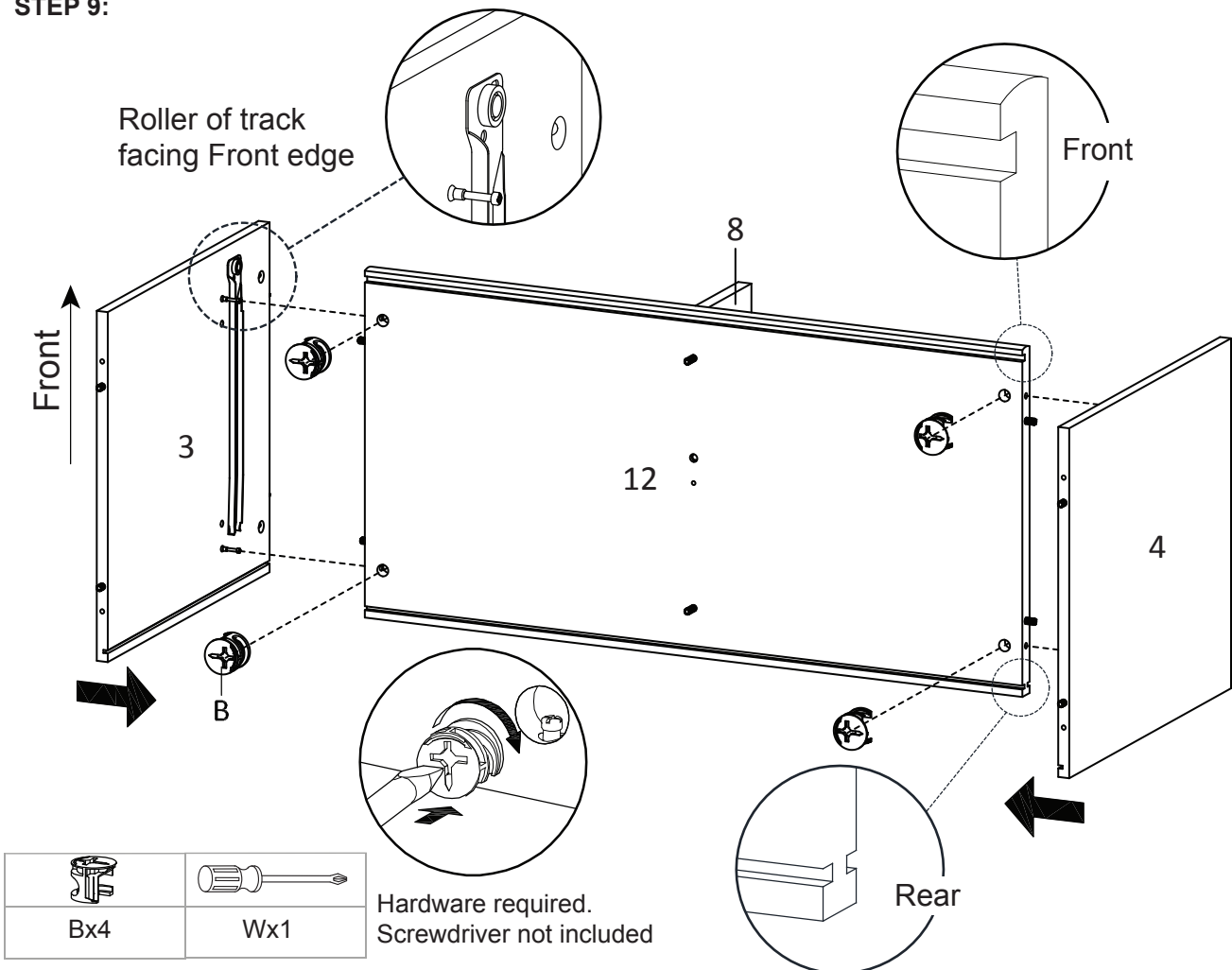

STEP 10:

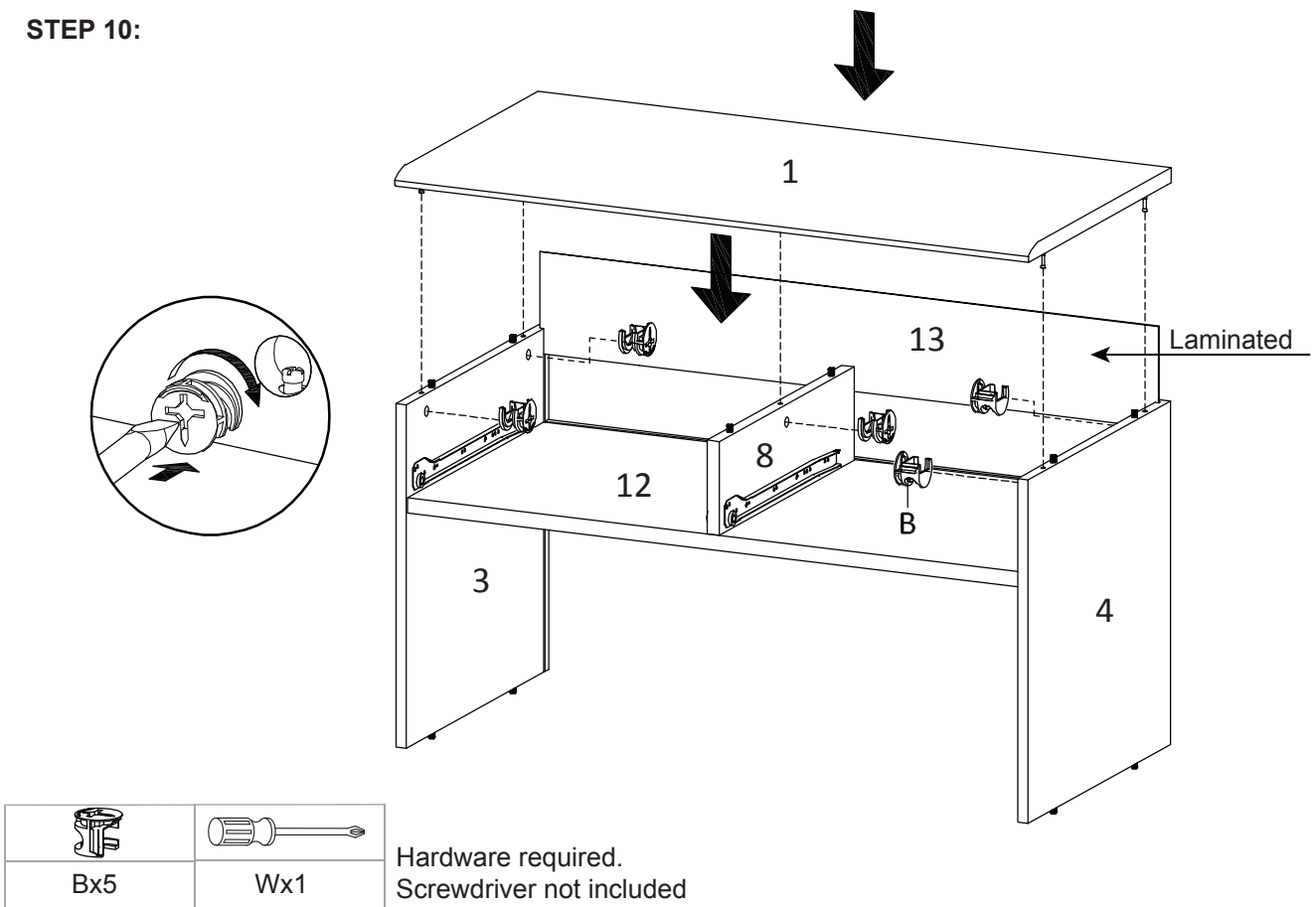

STEP 11:

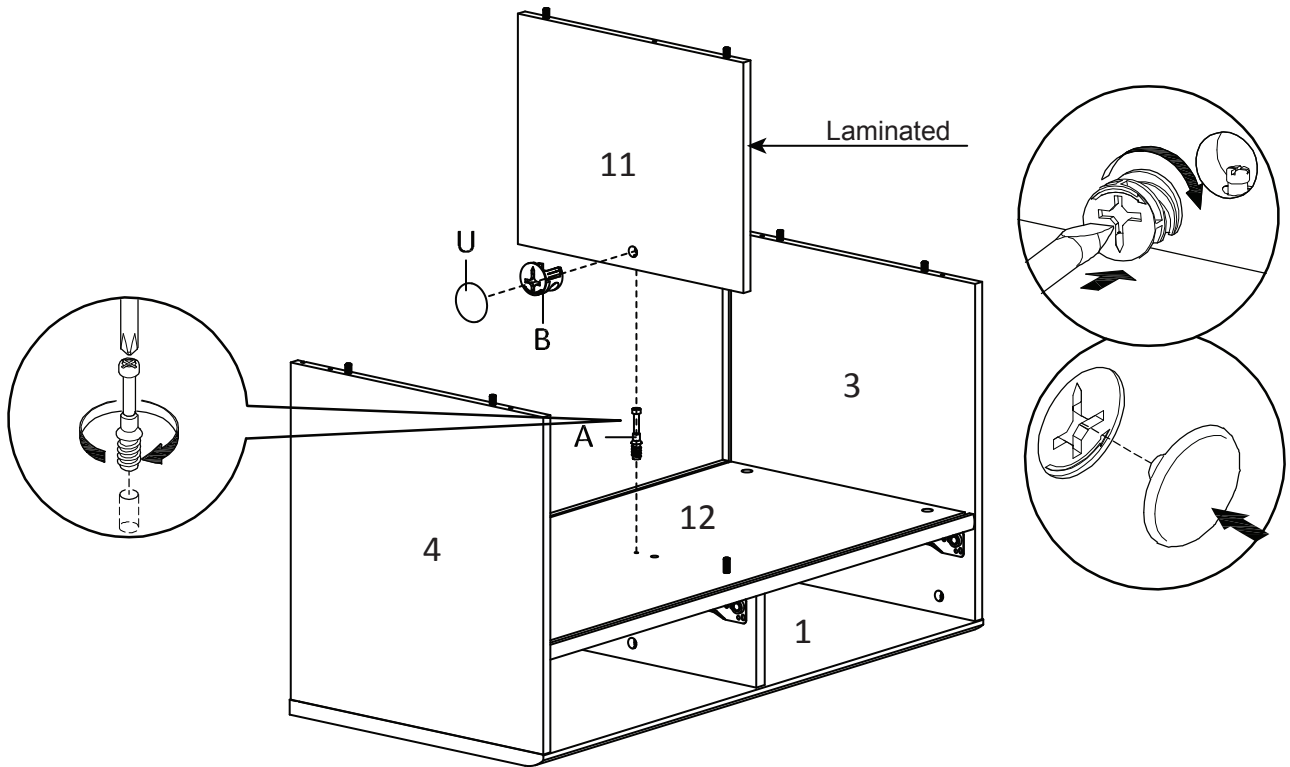

Ax1	Bx1	Ux1	Wx1

Hardware required.
Screwdriver not included

STEP 12:

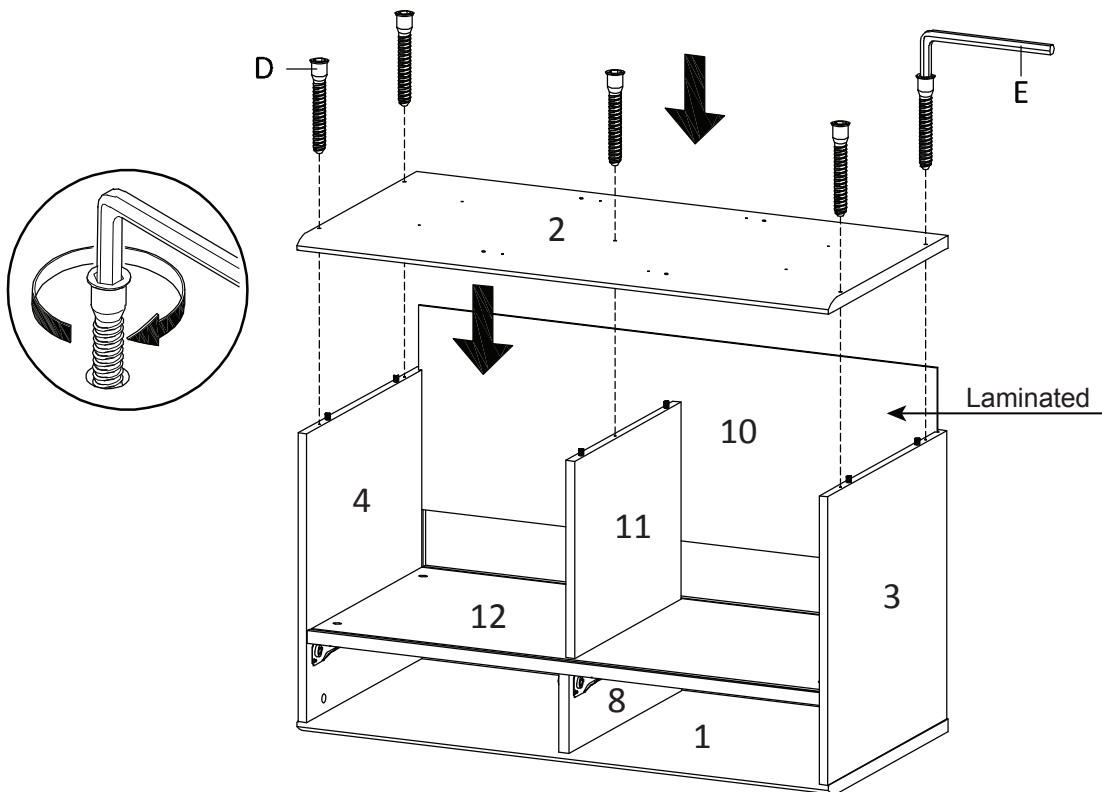



Dx5	E

Hardware required.

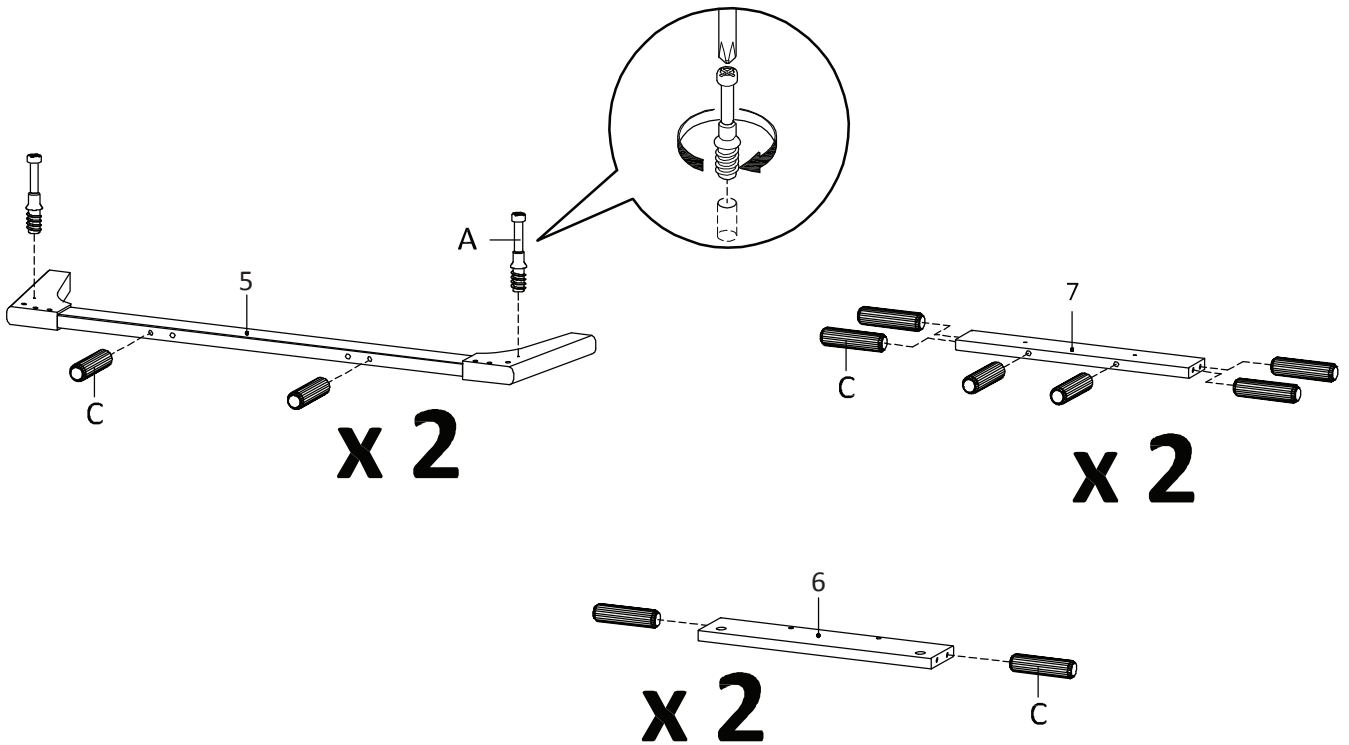
STEP 13:

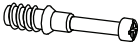

		
Ax4	Cx20	Wx1

Hardware required.
Screwdriver not included

STEP 14:

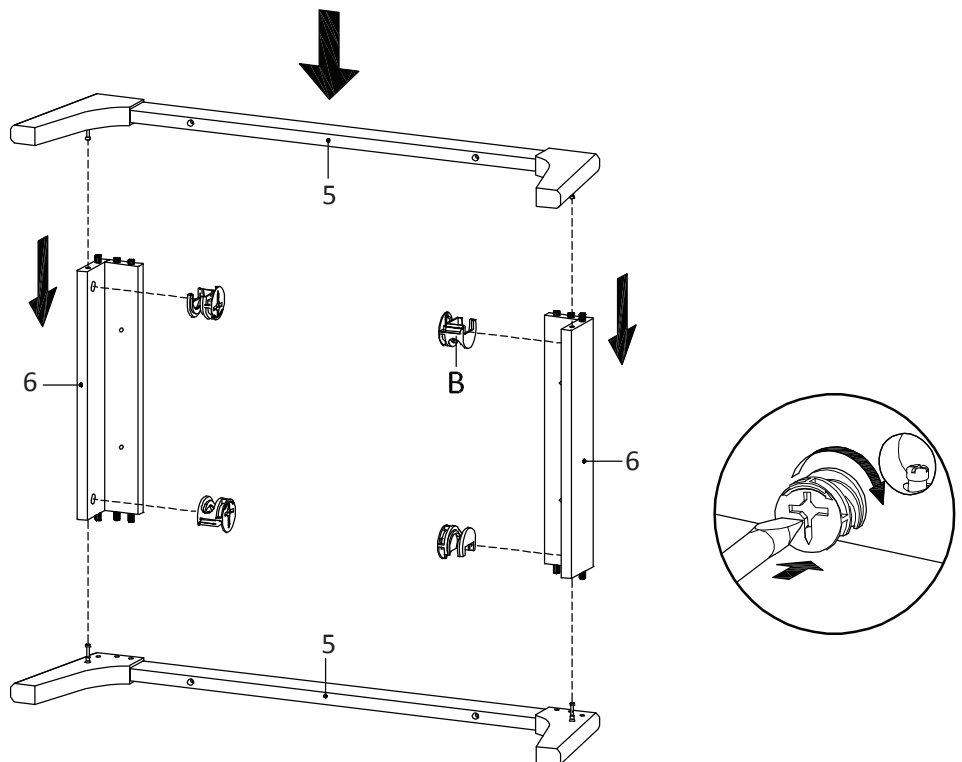
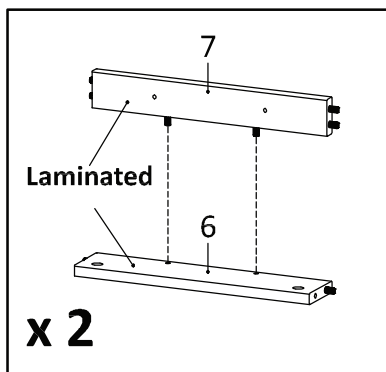

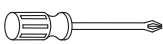
	
Bx4	Wx1

Hardware required.
Screwdriver not included

STEP 15:

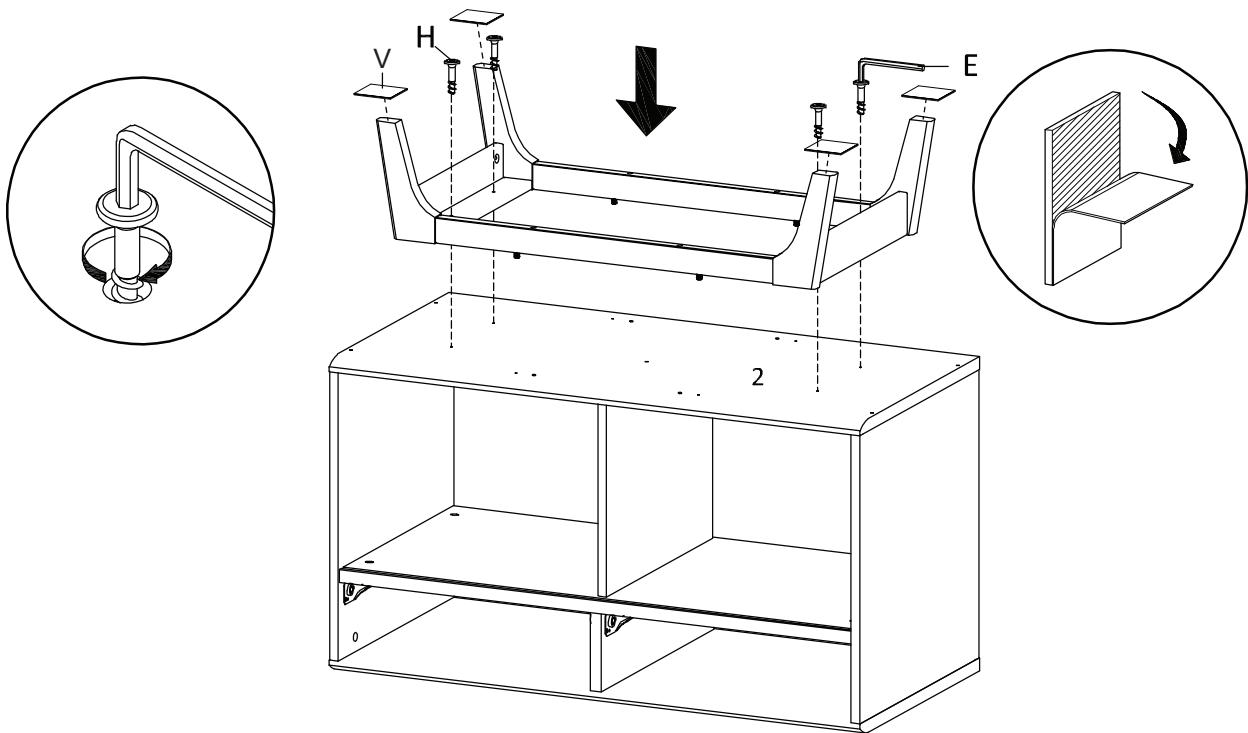

E	Hx4	Vx4

Hardware required.

STEP 16:

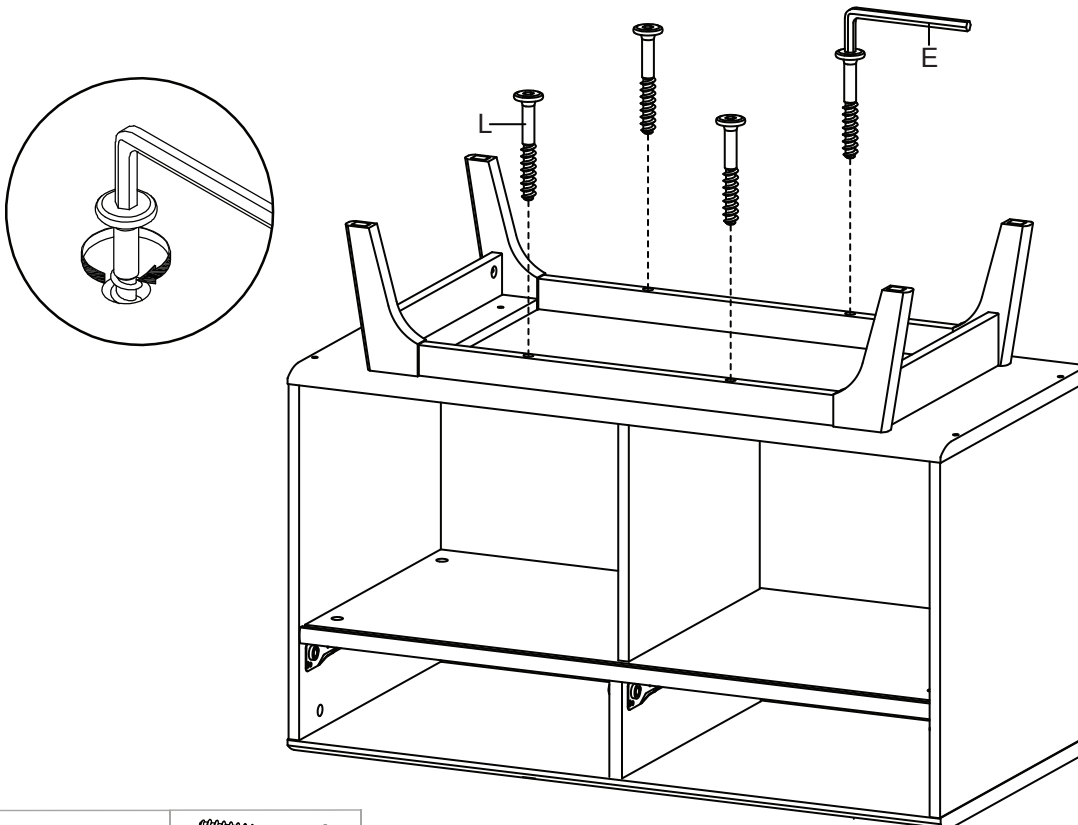

E	Lx4

Hardware required.

STEP 17:

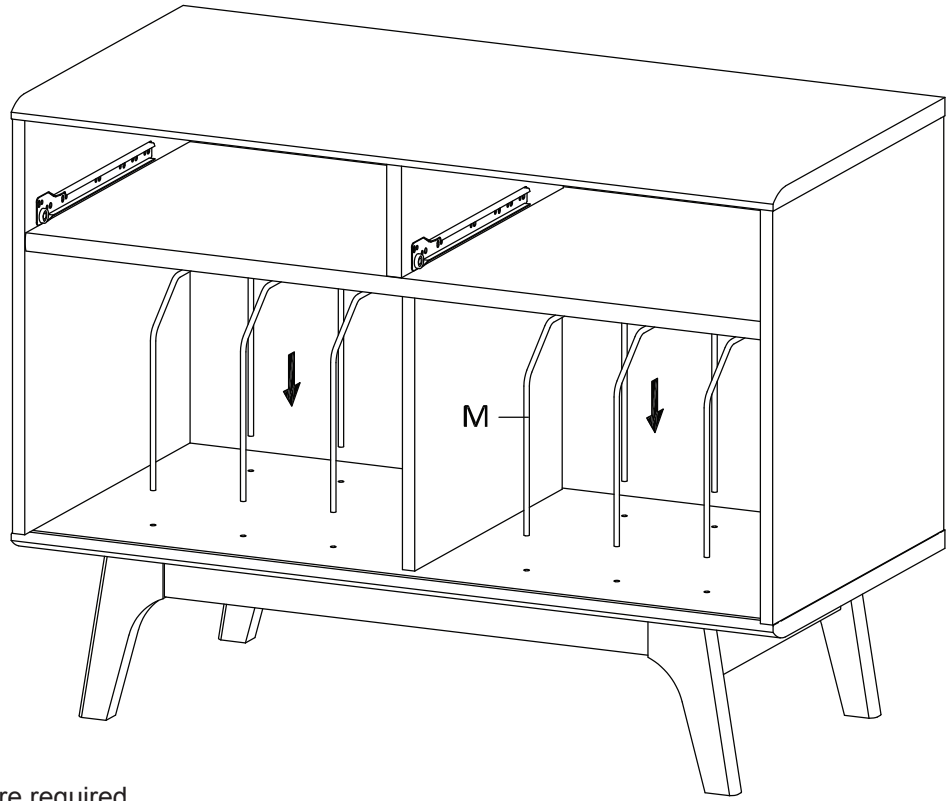

Mx6

Hardware required.

STEP 18:

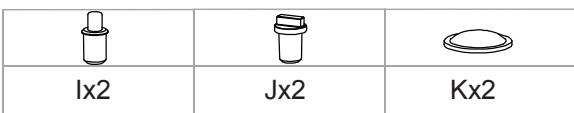
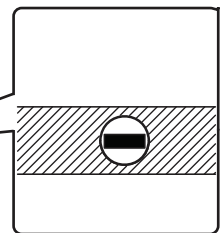
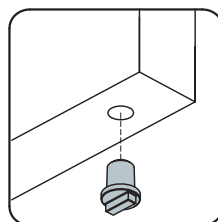
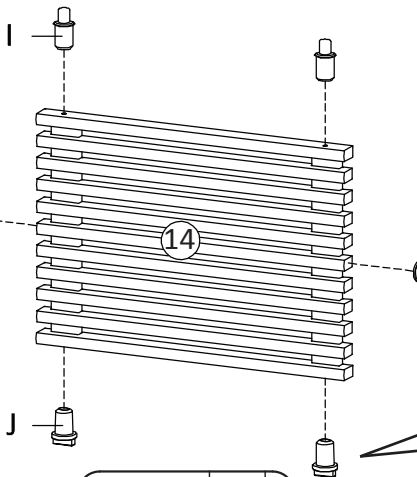
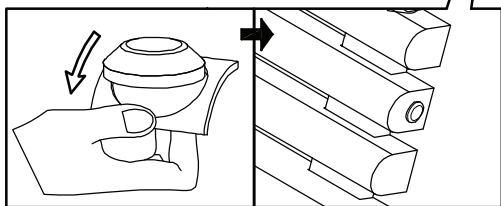
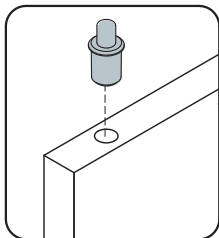

Hardware required.

STEP 19:

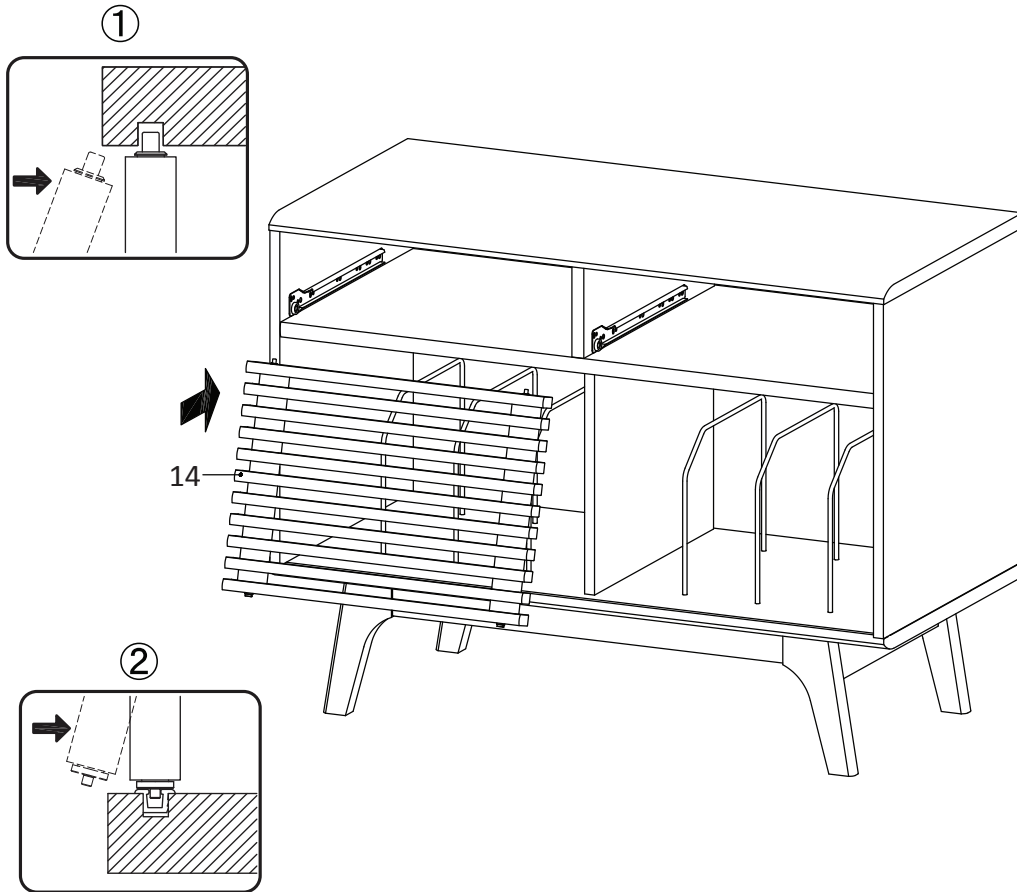

STEP 20:

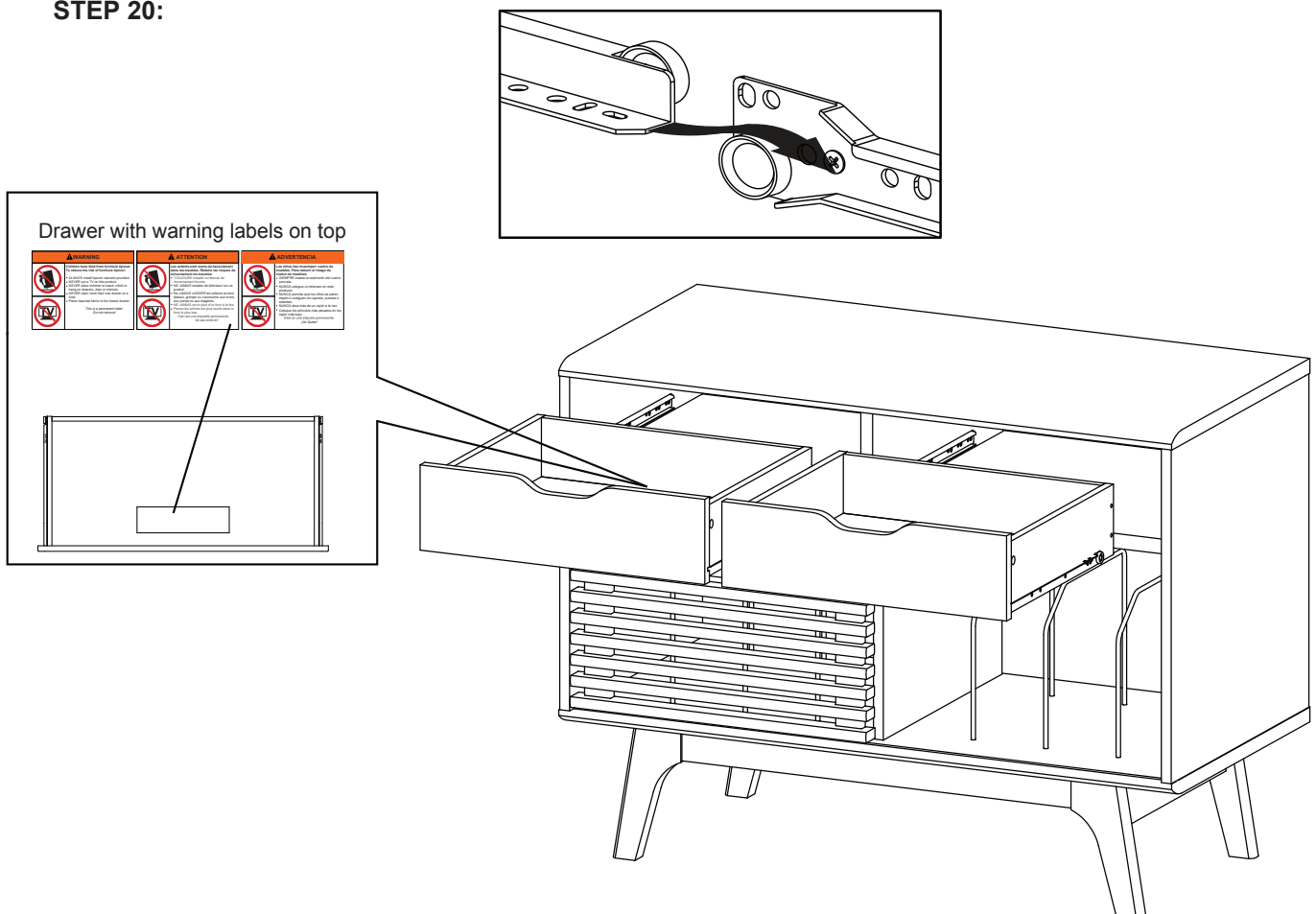

STEP 21:

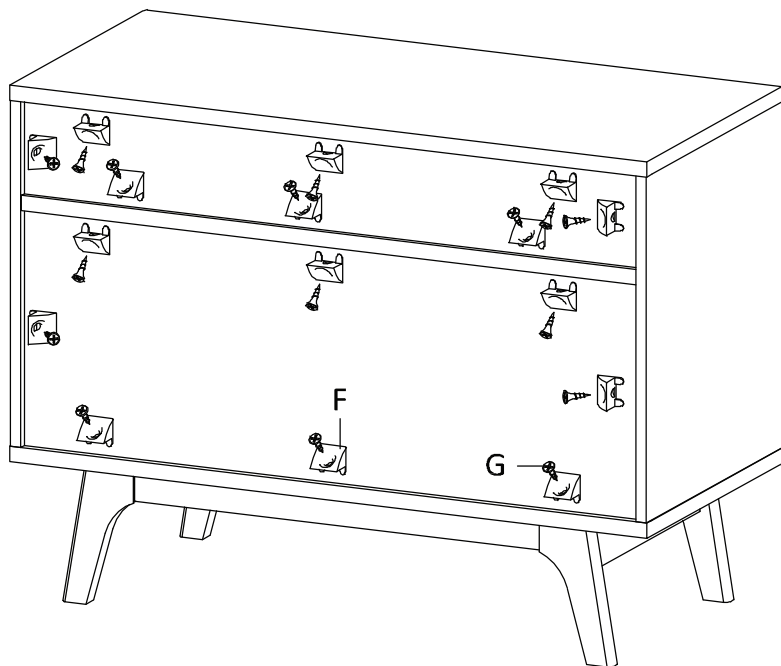
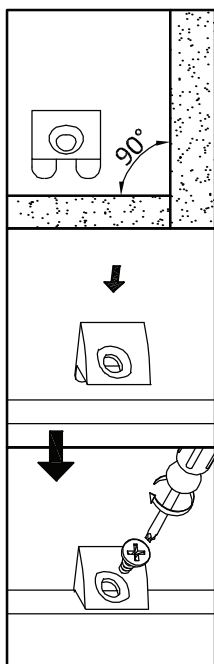

Fx16	Gx16	Wx1

Hardware required.
Screwdriver not included

STEP 22:

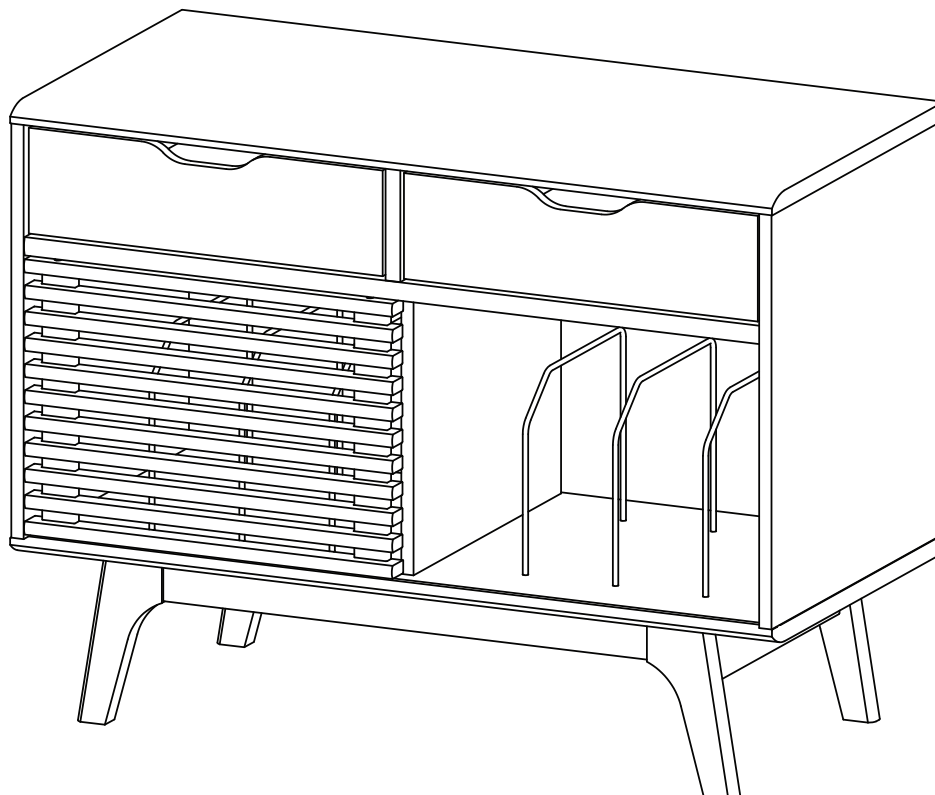

Assembly is complete. The Cabinet is ready to enjoy now !