

# EEI - 1384/1491/3779 CHAIR

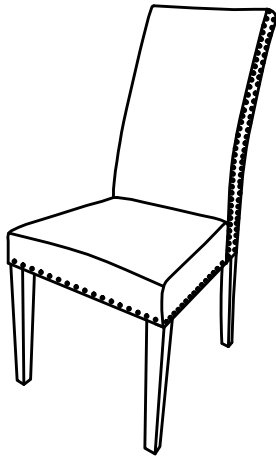





Thank you for purchasing the MODWAY CHAIR!

Before you start, here is some helpful advice:

1. We suggest you spend a short time reading through this leaflet and then follow the simple step by step instructions.
2. Owing to the size and weight of the chair, we recommend that it is assembled by two adults, on a carpeted or padded area, in the room that it is intended for. Approximate assembly time: 30 minutes.
3. Please do not use any tools other than those provided or recommended in these instructions.
4. Please do not throw away any of the packaging or instructions until you have checked all the components and hardware and the furniture is fully assembled.
5. Assemble all components loosely until advised to tighten. Depending on use, it may be necessary to tighten the components from time to time, so please save the tools that have been provided.
6. Please keep all pieces out of reach of small children.



### Hardware:

A		JCBC BOLT M6 x 45mm	1 PCS
B		JCBC BOLT M6 x 60mm	4 PCS
C		JCBC BOLT M6 x 90mm	4 PCS
D		FLAT WASHER M6	9 PCS
E		SPRING WASHER M6	9 PCS
F		ALLEN KEY (BALL SHAPE) M4	1 PC

### Component:

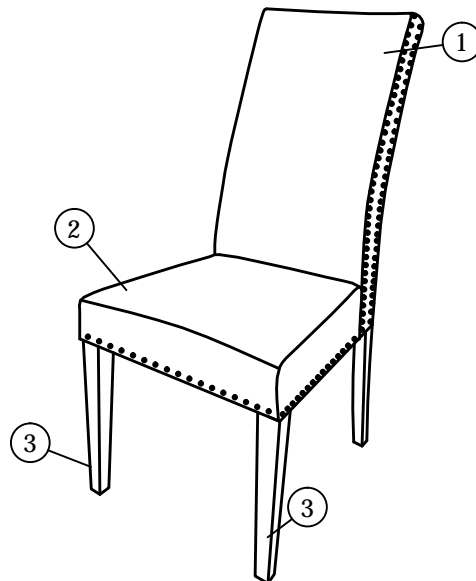

1	Chair Back	x1	2	Seat Frame	x1	3	Front Leg	x2
---	------------	----	---	------------	----	---	-----------	----

# EEI - 1384/1491/3779 CHAIR

## STEP 1:

Please put Chair back (1) upside down on a carpeted or padded area.

Then open the black fabric which is attached by the Velcro from back to front on bottom of the Seat Frame (2), The inside of the Seat Frame (2) will now be visible.

Attach Seat Frame (2) to Chair Back (1) by using 1 pieces of Bolt (A), 1 pieces of Spring Washer (E) and 1 pieces of Flat Washer (D) as shown.

DO not fully tighten Bolt (A) at this step also.

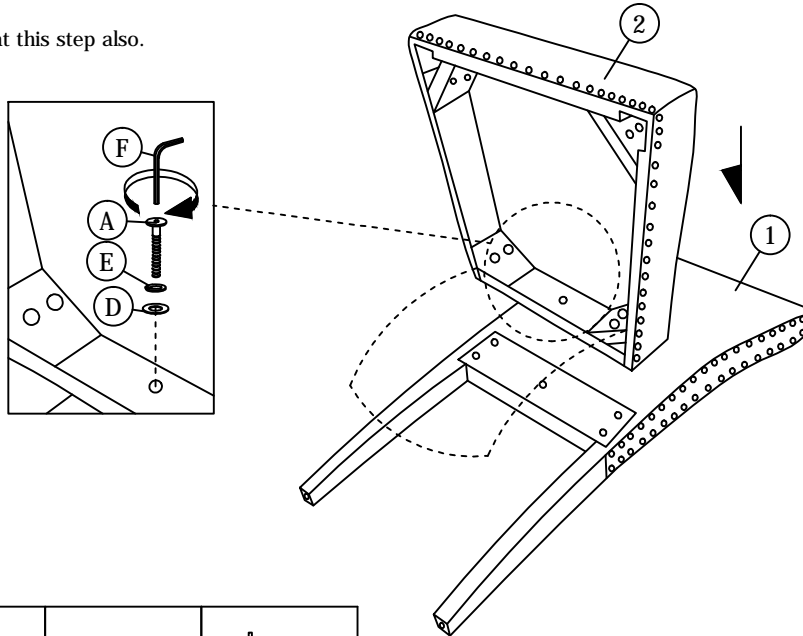

Ax1	Dx1	Ex1	Fx1

Hardware & Tool required

## STEP 2:

Attach Seat Frame (2) to Chair Back (1) by 4 pieces of Bolt (C), 4 pieces of Spring Washer (E) and 4 pieces of Flat washer (D) as shown.

Do not fully tighten Bolt (C) at this step.

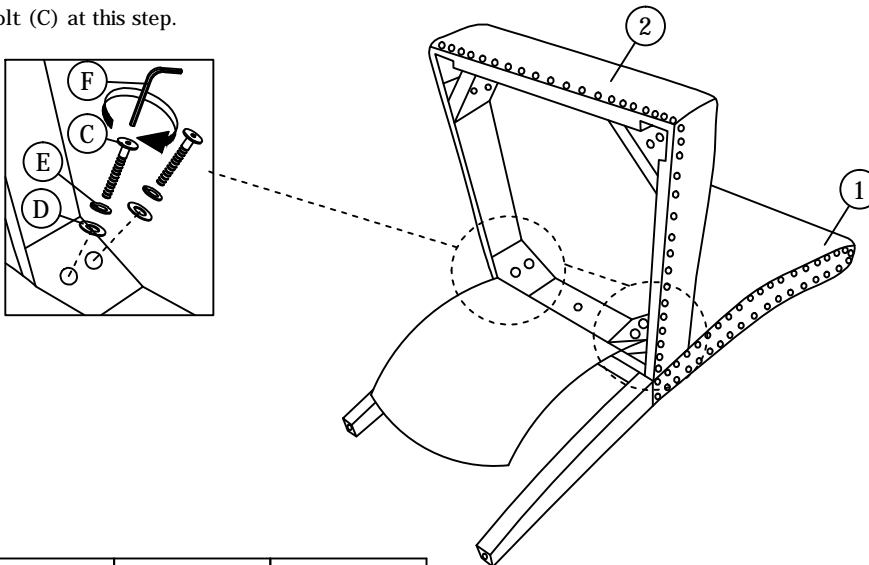

Cx4	Dx4	Ex4	Fx1

Hardware & Tool required

# EEI - 1384/1491/3779 CHAIR

## STEP 3:

Insert 1 piece of Front Leg (3) into the upper hole on the bottom of Seat Frame (2) as shown.  
 Attach by 2 pieces of Bolt (B), 2 pieces of Spring Washer (E) and 2 pieces of Flat Washer (D) as shown.  
 Repeat the same steps for Front leg (3)  
 Do not fully tighten Bolts (B) for either leg.

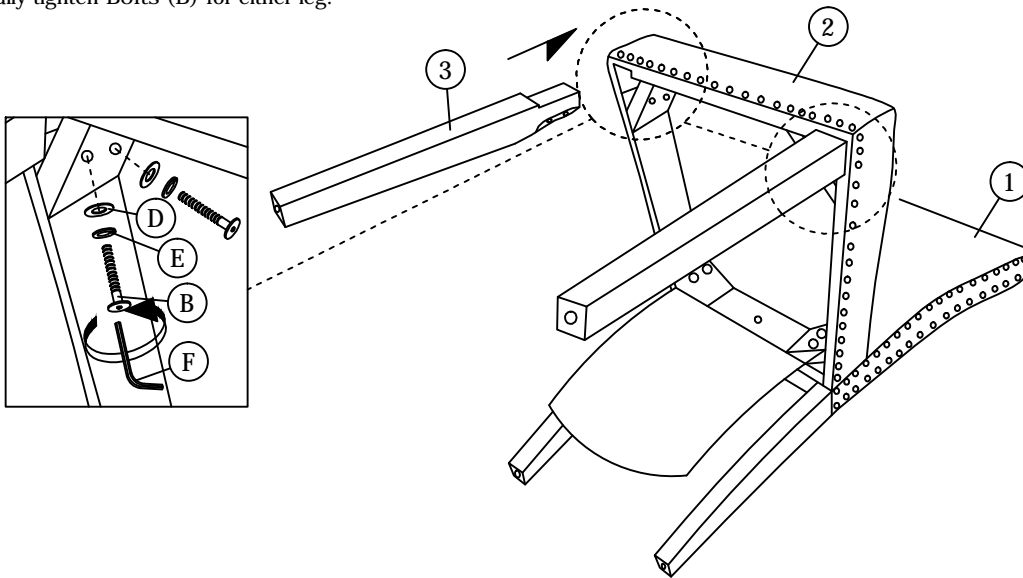

Bx4	Dx4	Ex4	Fx1

Hardware & Tool required

## STEP 4:

Carefully turn over the chair.  
 Please put a heavy object or seat one adult on top of the Seat Frame (2) to pressure the chair for leveling.  
 Fully tighten all Bolts (A,B,C) with Allen Wrench (F).

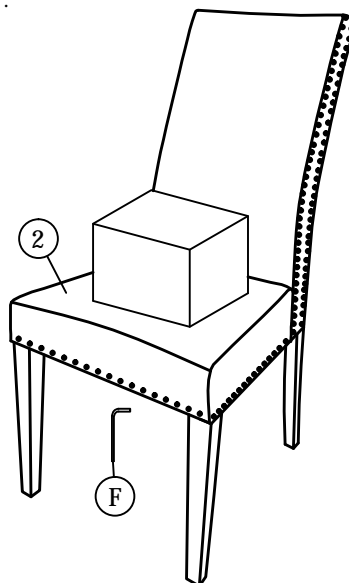

Fx1

Assembly is completed. The chair is ready to use now!

Hardware & Tool required