

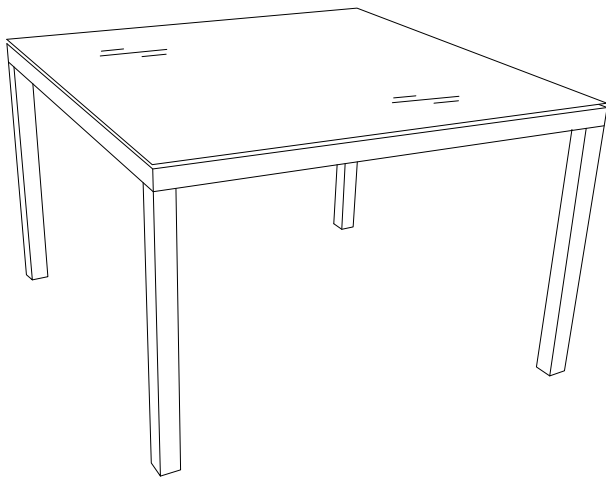





Thank you for purchasing the **MODWAY TABLE!**

Before you start, here are some helpful advice:

1. We suggest you spend a short time reading through this leaflet and then follow the simple step by step instructions.
2. Owing to the size and weight of the table, we recommend that it is assembled by two adults, on a carpeted or padded area, in the room that it is intended for. Approximate assembly time: 30 minutes.
3. Please do not use any tools other than those provided or recommended in these instructions.
4. Please do not throw away any of the packaging or instructions until you have checked all the components and hardware and the furniture is fully assembled.
5. Assemble all components loosely until advised to tighten. Depending on use, it may be necessary to tighten the components from time to time, so please save the tools that have been provided.
6. Please keep all pieces out of reach of small children.



Hardware:

A		Double-End Bolt	x 4
B		Nut 1/4"	x 8
C		Spring Washer 1/4"	x 8
D		Flat Washer 1/4"	x 8
E		Wrench 1/4"	x 1
F		Plastic Cover	x 4

Component:

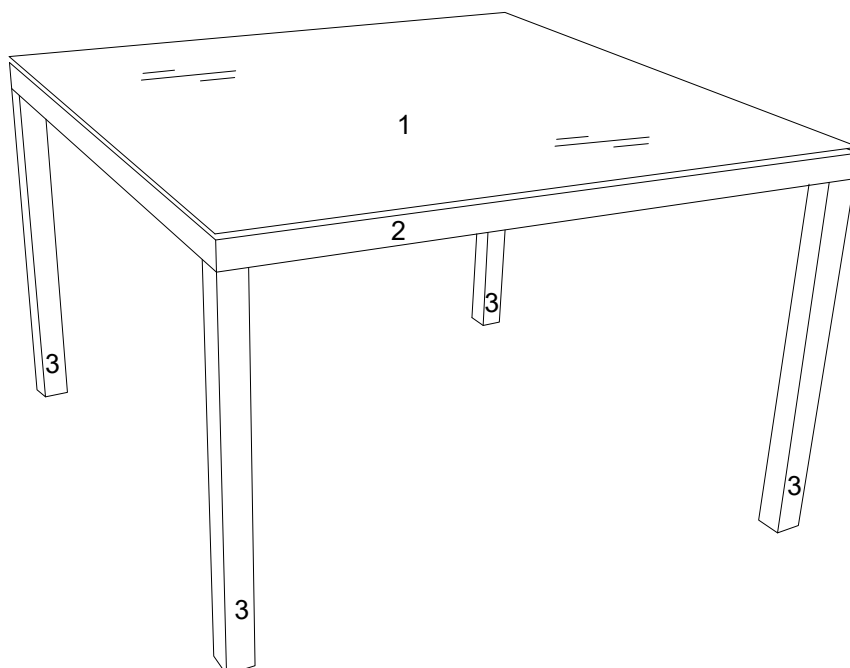

1 Table Glass x1	2 Table Top x1	3 Table Leg x4
------------------	----------------	----------------

STEP 1:

Secure 1 piece of **Nut (B)** into one end of **Double-end Bolt (A)** by hand as shown.
Repeat the same steps for the remaining **Double-end Bolts (A)**.

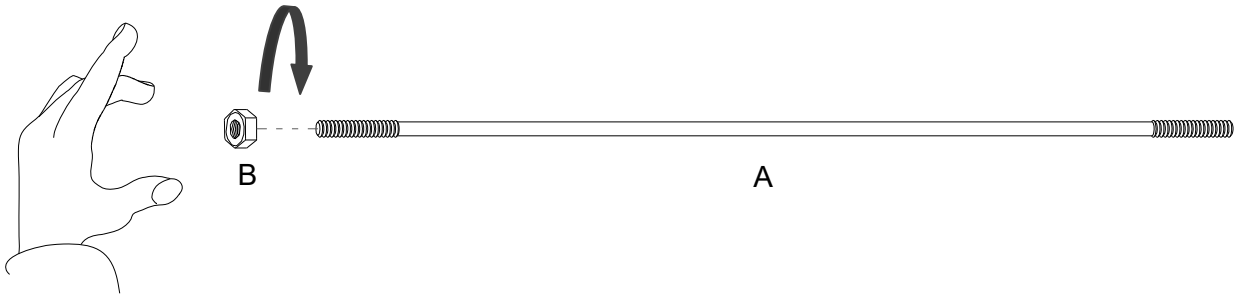

Ax4	Bx4

Hardware & Tool required

STEP 2:

Please put **Table Top (2)** upside down on a carpeted or padded area.
Secure 4 pieces of **Double-End Bolt (A)** into the bottom of **Table Top (2)** as shown.
Secure the assembled **Nuts (B)** at step 1 to **Table Top (2)** tightly by hand.

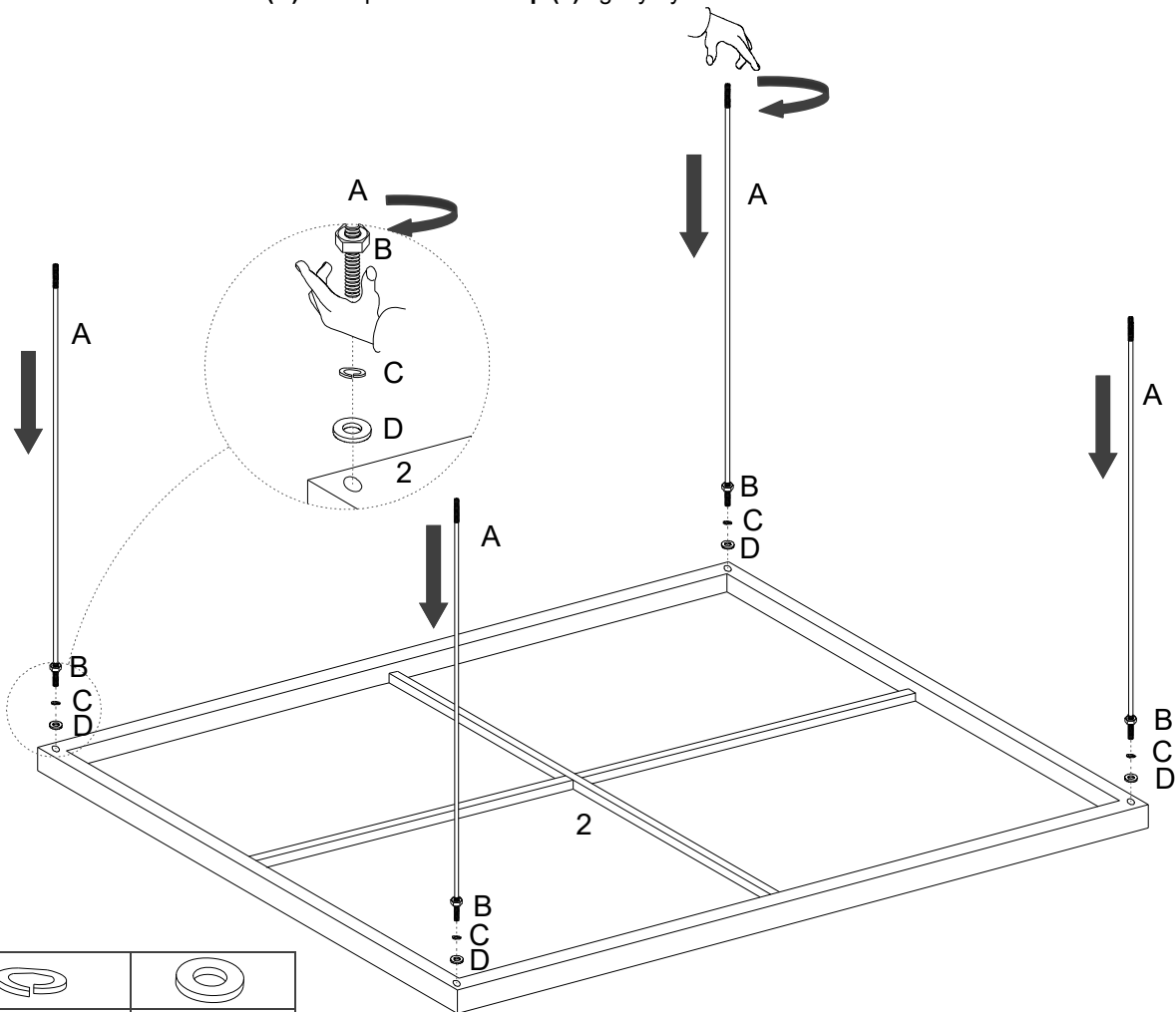

Cx4	Dx4

Hardware & Tool required

STEP 3:

Put 4 pieces of **Table Leg (3)** to **Table Top (2)** through the assembled **Double-End Bolt (A)** as shown.

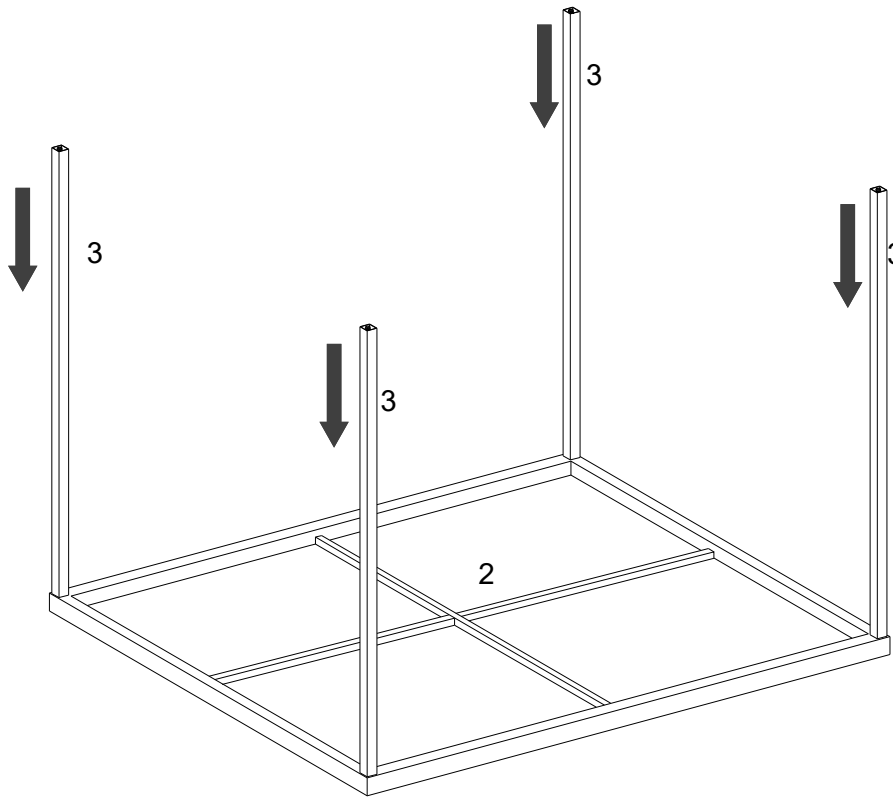

STEP 4:

Secure 4 pieces of **Nut (B)**, 4 piece of **Spring Washer (C)**, and 4 pieces of **Flat Washer (D)** to the end of assembled **Double-End Bolt (A)** as shown.

Use **Wrench (E)** to tighten **Nuts (B)** clockwise until secure.

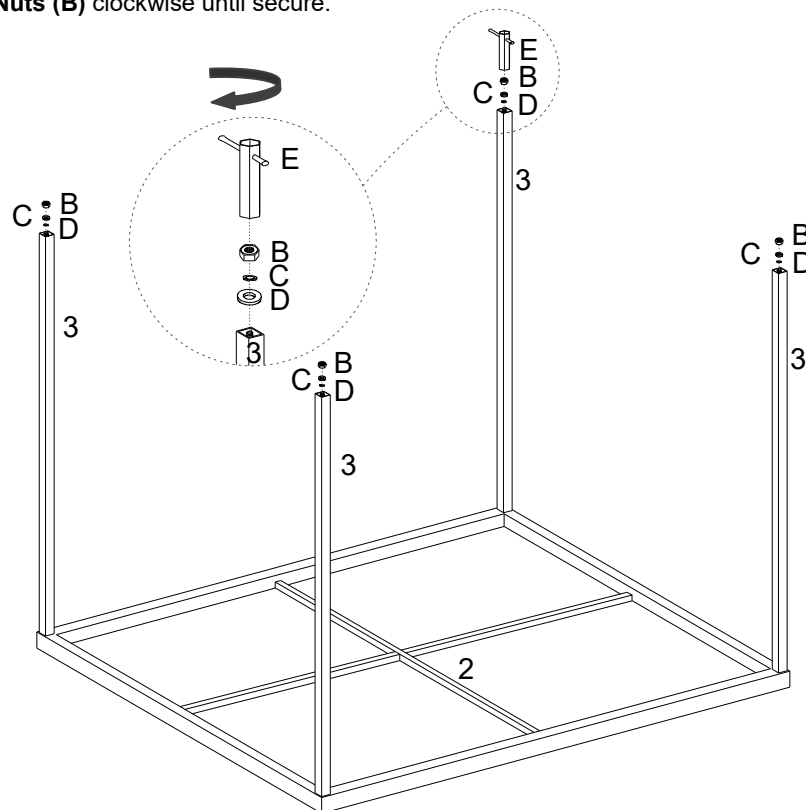

Bx4	Cx4	Dx4	Ex1

STEP 5:

Insert 4 pieces of **Plastic Cover (F)** into the assembled **Table Leg (3)** as shown.

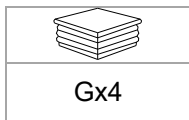
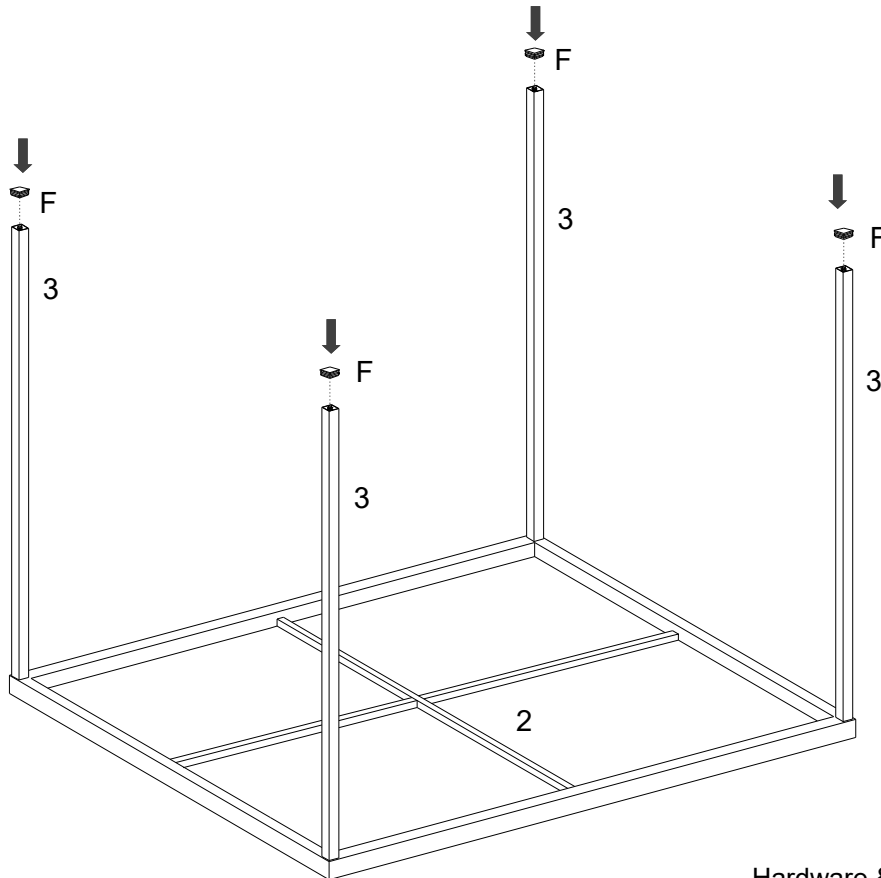

Hardware & Tool required

STEP 6:

Carefully turn over the assembled table.

Put **Table Glass (1)** to the **Table Top (2)** as shown.

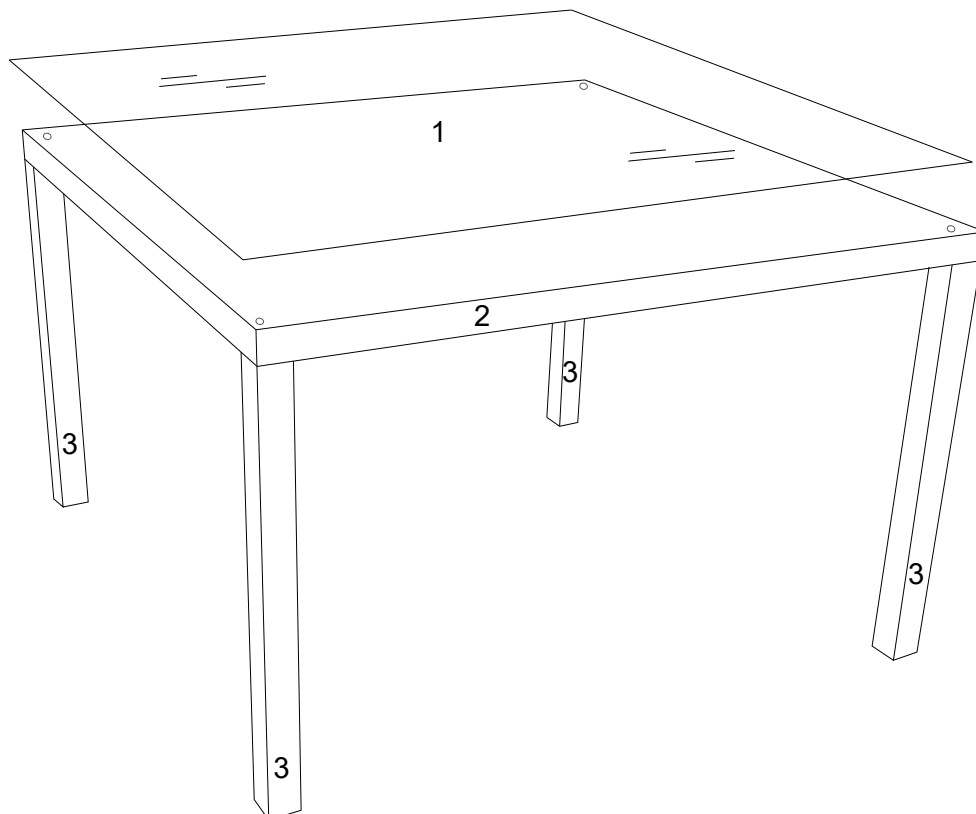

Assembly is complete. Your table is ready to be used now!