

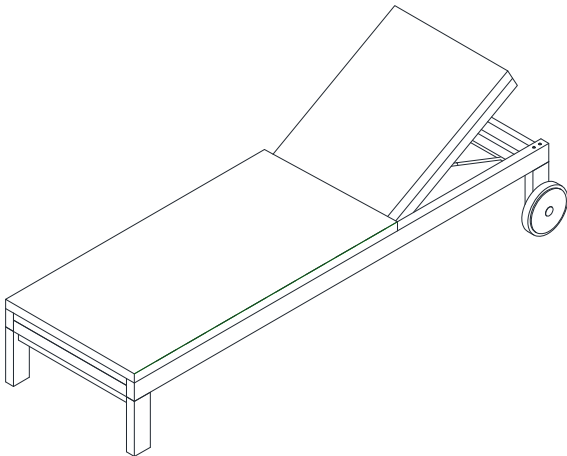





Thank you for purchasing the **MODWAY CHAISE** !

Before you start, here is some helpful advice:

1. We suggest you spend a short time reading through this leaflet and then follow the simple step by step instructions.
2. Owing to the size and weight of the chaise, we recommend that it is assembled by two adults, on a carpeted or padded area, in the room that it is intended for. Approx assembly time: 30 minutes.
3. Please do not use any tools other than those provided or recommended in these instructions.
4. Please do not throw away any of the packaging or the instruction until you have checked all the components and hardware and the furniture is fully assembled. Please ensure that the packaging is disposed of in a safe environmentally friendly way.
5. Assemble all components loosely until advised to tighten. Depending on use, it may be necessary to tighten the components from time to time, so please save the tools that has been provided.
6. Please keep all fitting out of reach of children.



**Hardware:**

A		Bolt M6x90mm	x 8
B		Caster Bolt	x 2
C		Small Washer	x 2
C		Large Washer	x 2
E		Nut	x 2
F		Allen Wrench M4	x 1

**Component:**

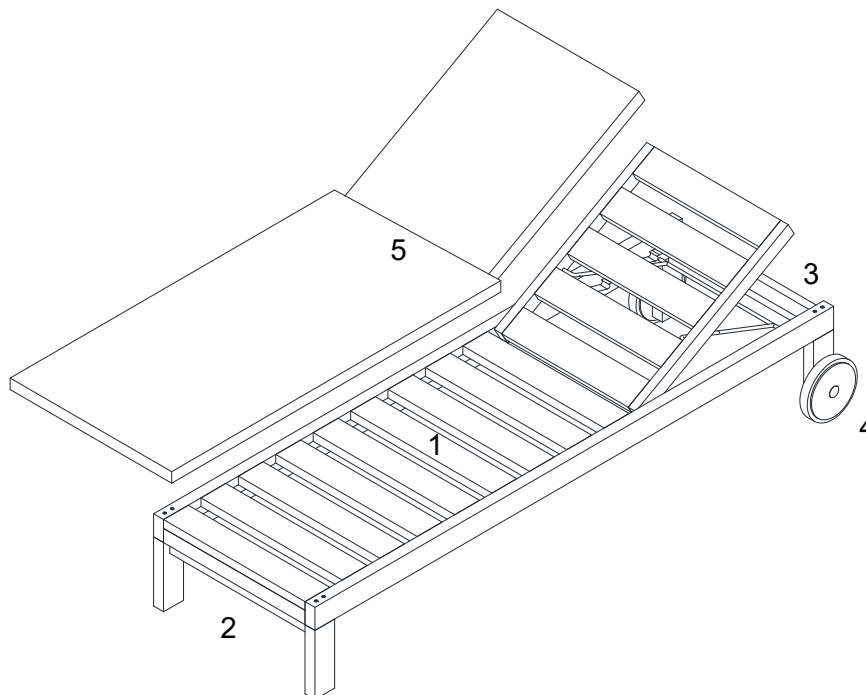

1	Chaise Body	x1	2	Front Frame	x1	3	Back Frame	x1
4	Caster	x2	5	Cushion	x1			

## STEP 1:

Please put **Chair Body (1)** upside down on a carpeted or padded area.

Insert the tenon on **Front Frame (2)** into the rabbet on the **Chaise Body (1)**.

Insert the tenon on **Back Frame (3)** into the rabbet on the **Chaise Body (1)**.

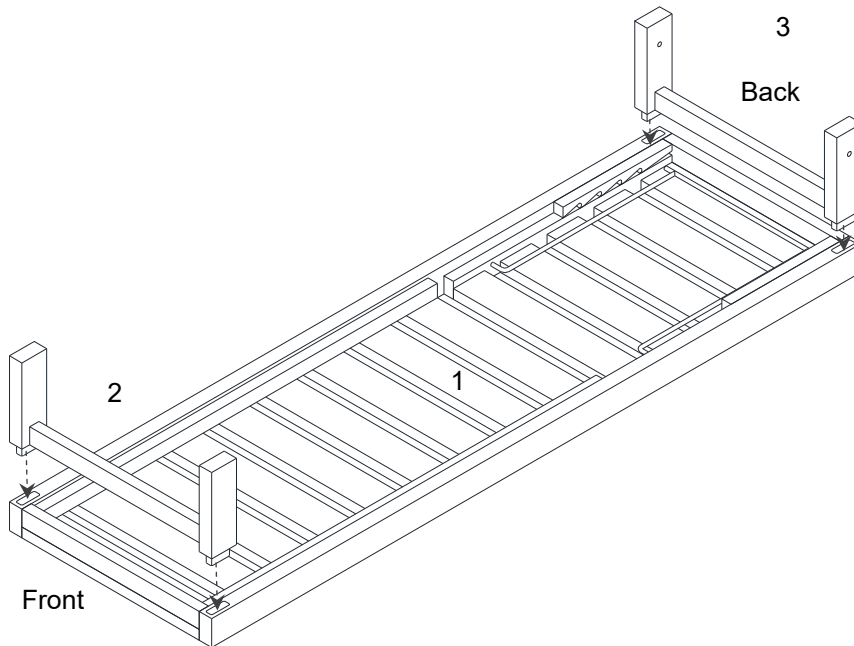

## STEP 2:



Carefully turn over the assembled **Chaise Body (1)**, **Front Frame (2)** and **Back Frame (3)**.

Insert 4 pieces of **Bolt (A)** into the pre-drilled holes on **Front Frame (2)** through the pre-drilled holes on **Chaise Body (1)**.

Repeat the same steps for the **Back Frame (3)**.

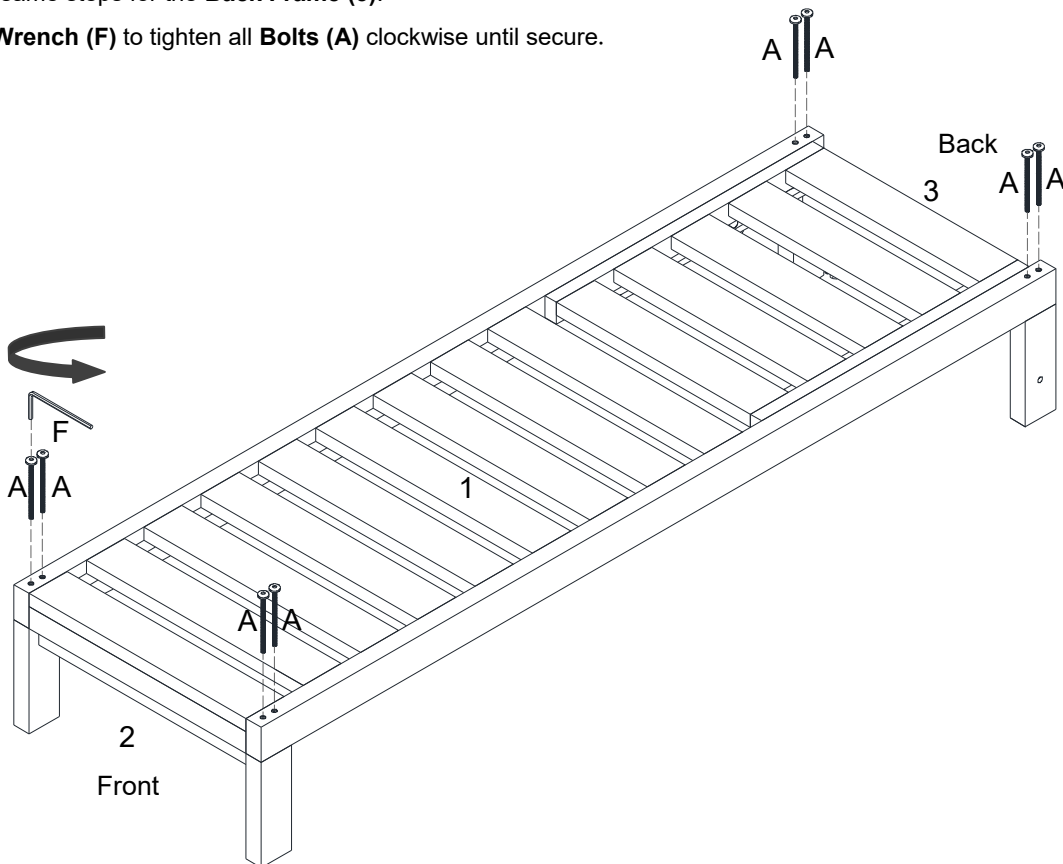
Use **Allen Wrench (F)** to tighten all **Bolts (A)** clockwise until secure.



	
Ax8	Ex1

Hardware & Tool required





## STEP 3:

Position **Casters (2)** to the **Back Frame (3)** as shown.

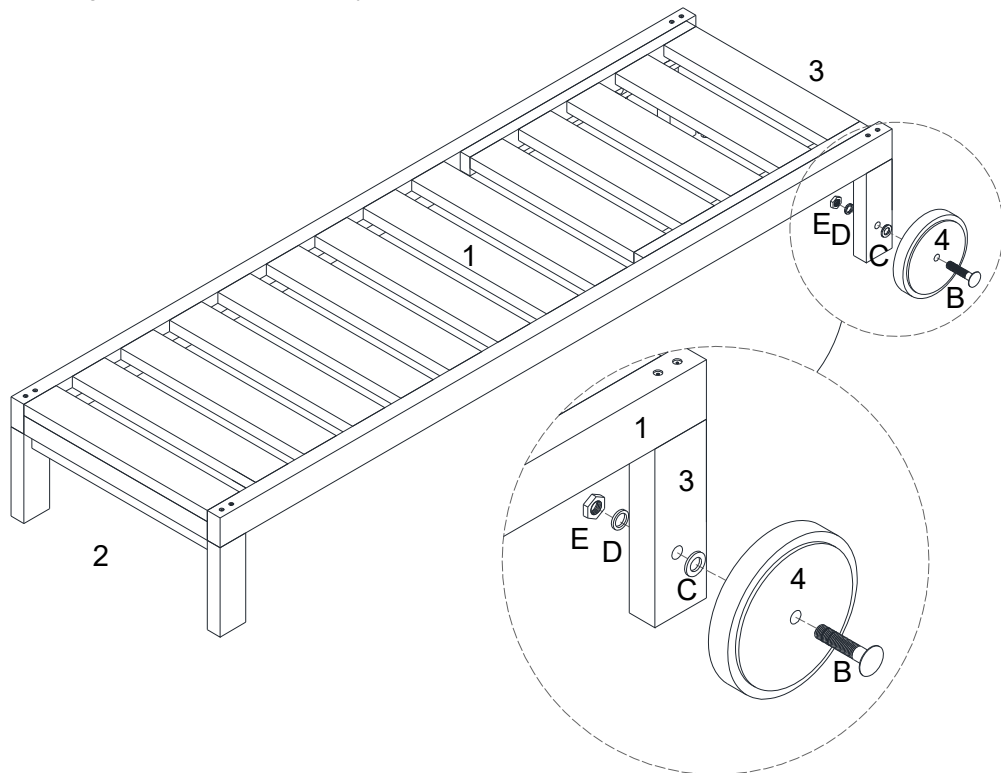
Insert 1 piece of **Caster Bolt (B)** with 1 piece of **Large Washer (C)** and 1 piece of **Small Washer (D)** into the pre-dilled holes on the **Back Frame (3)** through the holes on each **Caster (4)**.

Use 2 pieces of **Nuts (E)** to tighten **Caster Bolts (B)** by hand.



			
Bx2	Cx2	Dx2	Ex2

Hardware & Tool required

## STEP 4:

Position the assembled chaise to the location your desired.

The height of the back part on **Chaise Body (1)** is adjustable if you want.

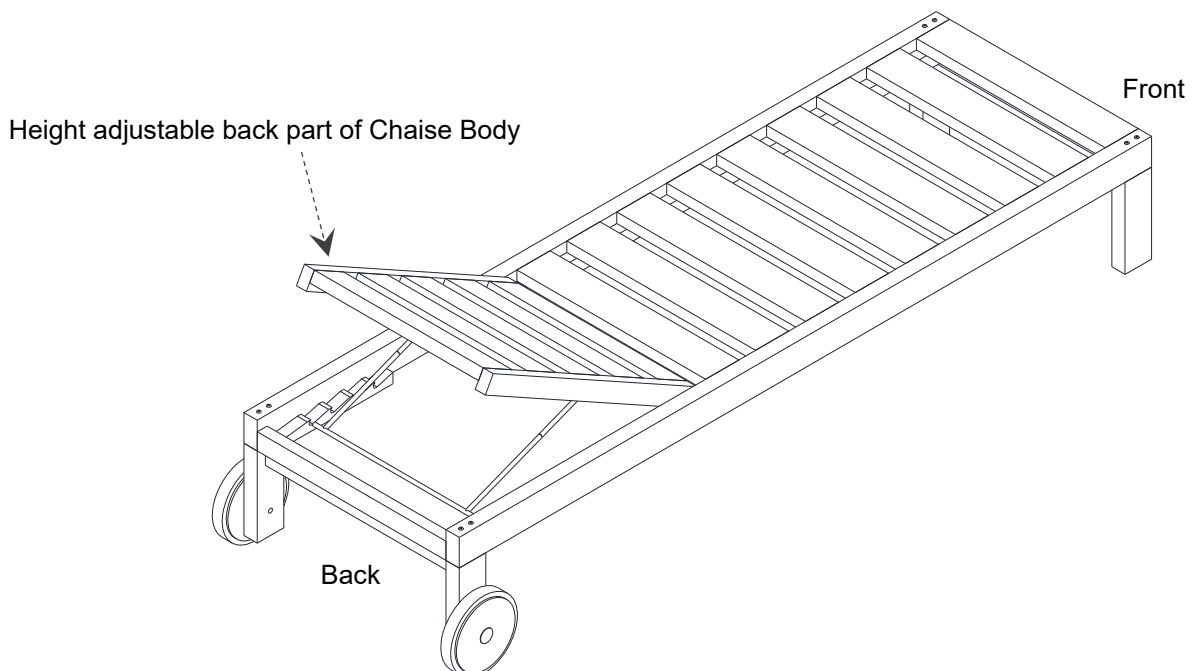

## STEP 5:

Put **Cushion (5)** into the assembled chair as shown.

Tie **Cushion (5)** to **Chaise Body (1)** by using the banding on the bottom of **Cushion (5)** as shown.

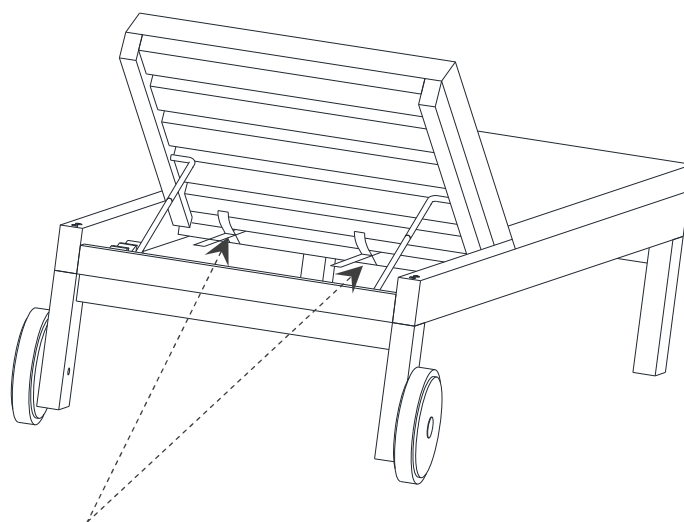
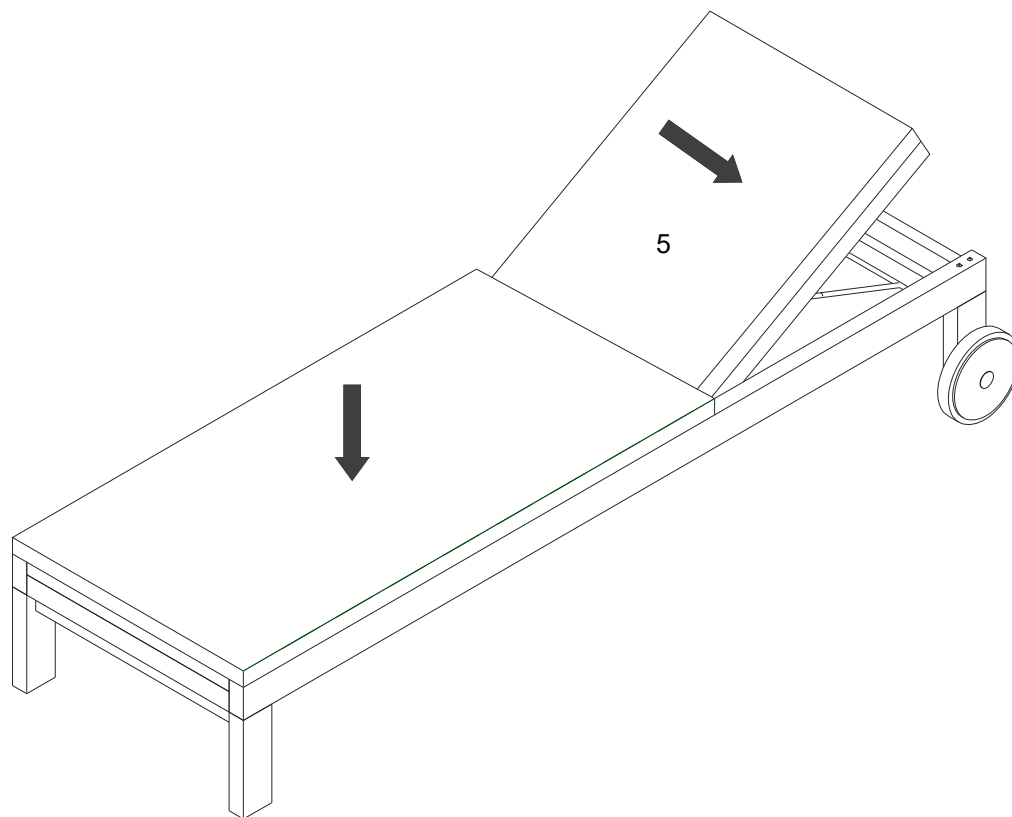

Banding on the bottom of cushion

Assembly is complete. Your Chaise table is ready to be used now!