

Thank you for purchasing the **MODWAY BAR TABLE!**

Before you start, here is some helpful advice:

1. We suggest you spend a short time reading through this leaflet and then follow the simple step by step instructions.
2. Owing to the size and weight of the table, we recommend that it is assembled by two adults, on a carpeted or padded area, in the room that it is intended for. Approx assembly time: 30 minutes.
3. Please do not use any tools other than those provided or recommended in these instructions.
4. Please do not throw away any of the packaging or the instruction until you have checked all the components and hardware and the furniture is fully assembled. Please ensure that the packaging is disposed of in a safe environmentally friendly way.
5. Assemble all components loosely until advised to tighten. Depending on use, it may be necessary to tighten the components from time to time, so please save the tools that has been provided.
6. Please keep all fitting out of reach of children.

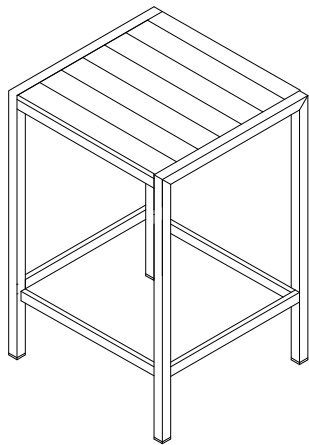

Hardware:

- | | | | |
|---|--|-----------------|-----|
| A | | Bolt M6x20mm | x20 |
| B | | Bolt M6x25mm | x8 |
| C | | Allen Wrench M4 | x1 |

Component:

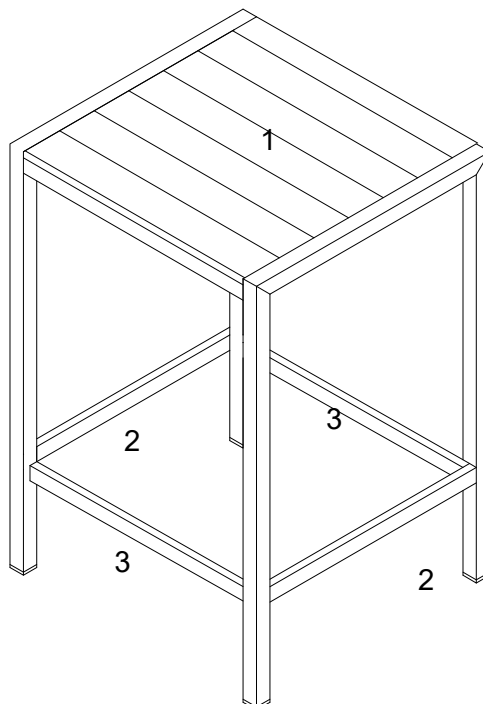

- | | | | | | | | | |
|---|-----------|----|---|-----|----|---|------------------|----|
| 1 | Table Top | x1 | 2 | Leg | x2 | 3 | Bottom Stretcher | x2 |
|---|-----------|----|---|-----|----|---|------------------|----|

STEP 1:

Remove the plastic covers which pre-install in the end of the **Table Top (1)** by using **Allen Wrench (C)**.

Please Stand 1 piece of **Leg (2)** on a carpeted or padded area.

Insert 1 piece of **Table Top (1)** and 2 pieces of **Bottom Stretcher (3)** to the **leg (2)** as shown.

Insert 4 pieces of **Bolts (B)** from the pre-drilled holes on the bottom of the **Table Top (1)** into each side on the bottom of **Leg (2)**.

Insert 2 pieces of **Bolts (A)** from the pre-drilled holes on the side rail of the **Table Top (1)** into each end of **Leg (2)** as shown.

Insert 8 pieces of **Bolts (A)** from the pre-drilled holes on the side of the **Table Top (1)** and **Bottom Stretcher (3)** into the **Leg (2)** as shown.

Do not fully tighten **Bolts (A&B)** at this step.

Repeat the same steps for the remaining 1 piece of **Leg (2)**. Use **Allen Wrench (C)** to tighten all **Bolts (A&B)** clockwise until secure.

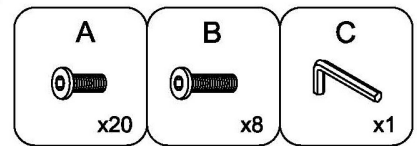
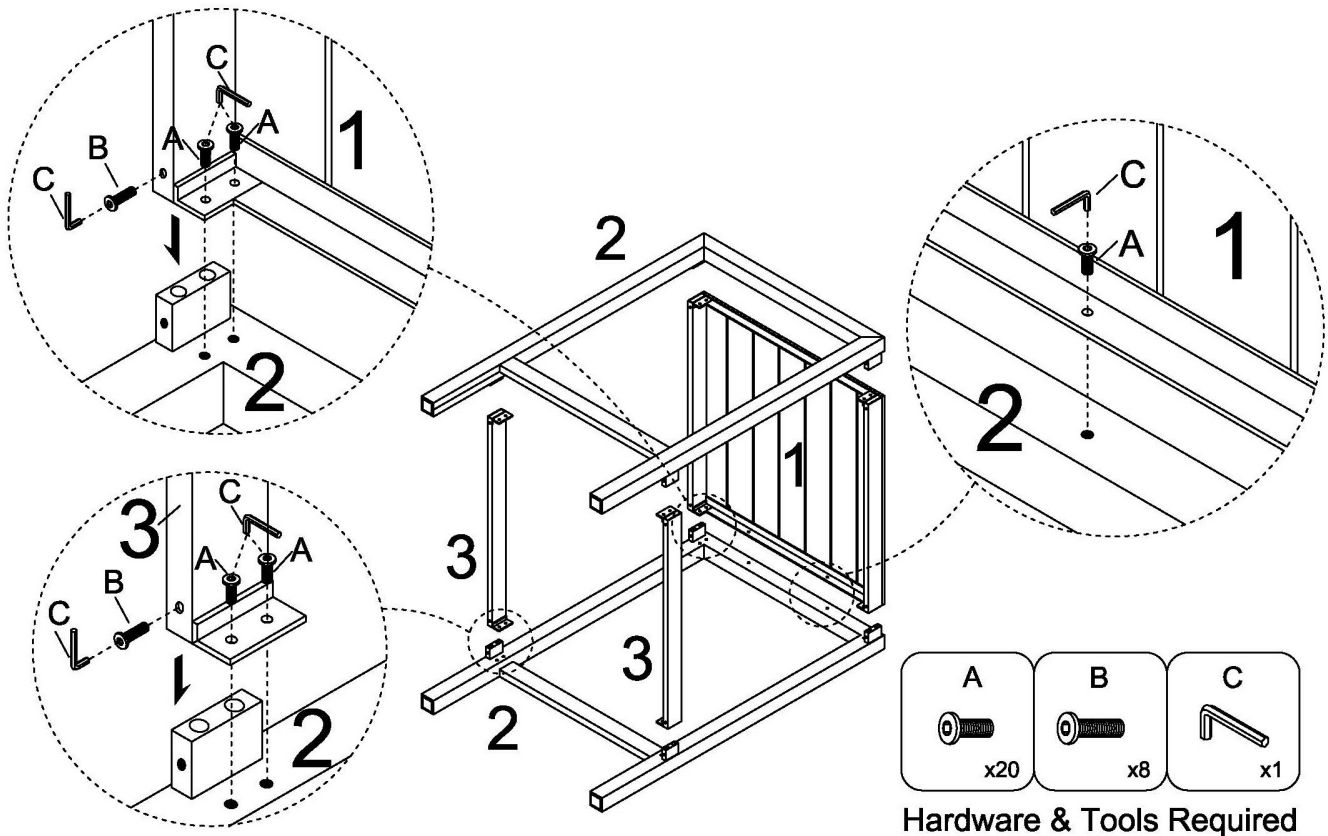

STEP 2:

Carefully turn over the assembled table.

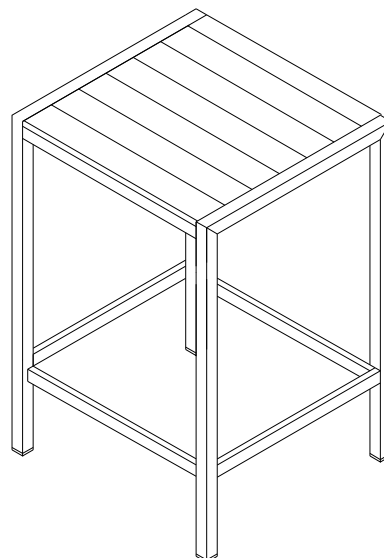

Assembly is completed. The table is ready to enjoy now!