









ASSEMBLY INSTRUCTIONS

ITEM NO: 55621

Thank you for purchasing this quality product. Be sure to check all packing material carefully for small parts that may have come loose inside the carton during shipment. (Note: Loosely thread all screws/bolts first. Once the item is assembled then completely tighten.)

PARTS LIST				HARDWARE LIST				
NO.	Description	Sketch	Quantity	NO.	Description	Sketch	Size	Quantity
A	Top		1	D	Lock washer		Φ1/5 " *1/50 "	8
B	Legs		4	E	Blots		Φ1/5 " *1/2 "	8
C	Board		1	F	Blots		3/25 "	8
				G	Angle iron		1/5 "	4
				H	Allen wrench		Φ4/25 "	1

STEP ONE:

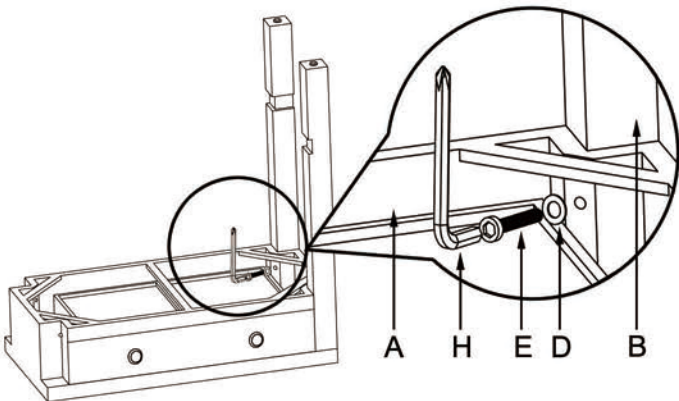

STEP TWO:

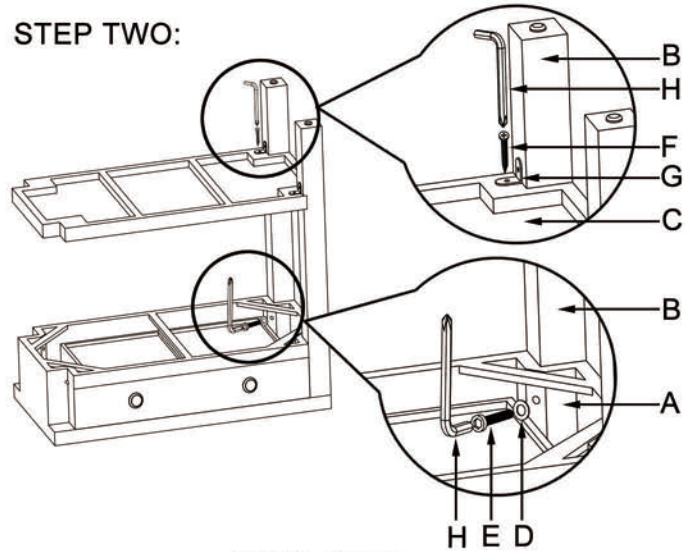

STEP THREE:

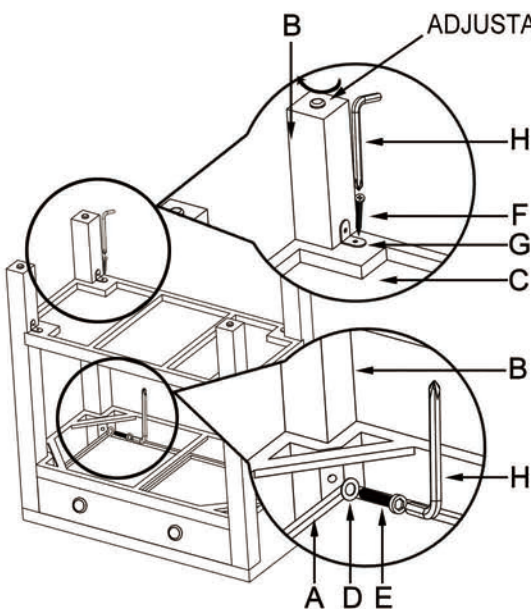

Tips for aligning doors:

Tip A: Sometimes the doors will no line up because of an uneven floor surface, try adjusting the levelers found on the botton of each foot to aid in correcting.

STEP FOUR:

