

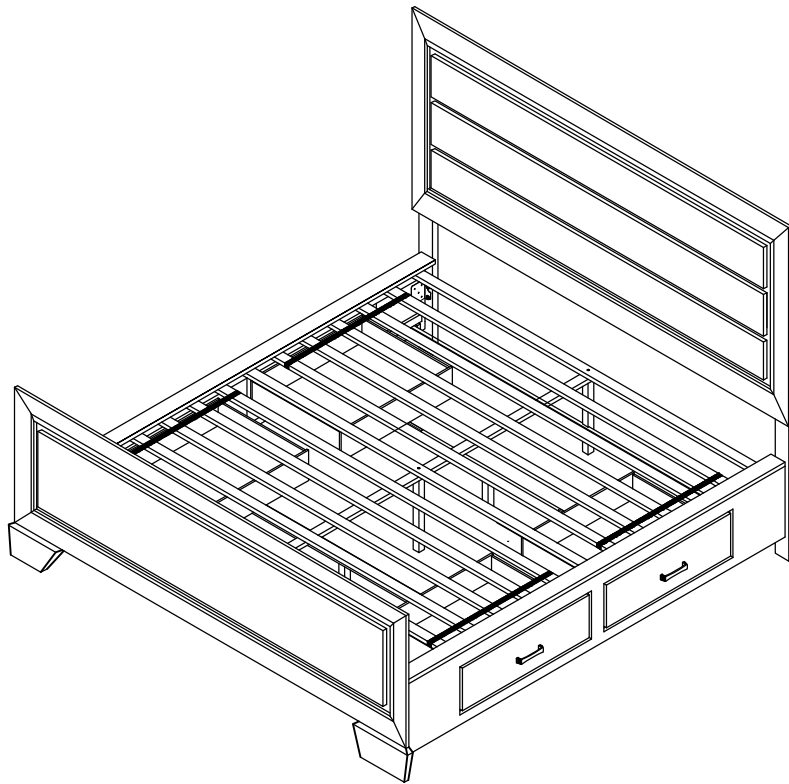

ASSEMBLY INSTRUCTIONS
COASTER FINE FURNITURE



Fine Furniture for every stage of life

204390KW(B1-B4)
California King Storage Bed

ITEM: 204390KW (B1-B4)



ASSEMBLY INSTRUCTIONS

ASSEMBLY TIPS:

- 1 . Remove hardware from box and sort by size.
- 2 . Please check to see that all hardware and parts are present prior to start of assembly.
- 3 . Please follow attached instructions in the same sequence as numbered to assure fast & easy assembly.



WARNING !

- 1 . Don't attempt to repair or modify parts that are broken or defective. Please contact the store immediately.
- 2 . This product is for home use only and not intended for commercial establishment.

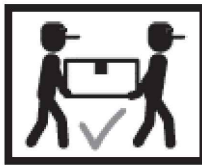



ASSEMBLY TIME



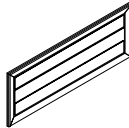

30 MINUTES

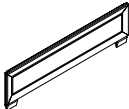

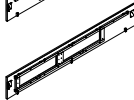
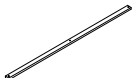

PARTS IDENTIFICATION

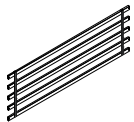
B1 (BOX 1)

A	HEADBOARD PANEL		1PC
B	LEFT HEADBOARD LEG		1PC
C	RIGHT HEADBOARD LEG		1PC
D	FOOTBOARD		1PC

B2 (BOX 2)

E	LEFT BED RAIL		1PC
F	RIGHT BED RAIL		1PC
G	BED SLAT WITH 3 HOLES		3PCS
H	DRAWER SLAT		2PCS
I	ROLL SLAT (5PCS)		2SETS
J	STORAGE FOOTBOARD SUPPORT LEG		2PCS

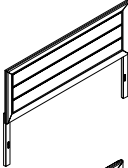
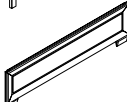
K	CENTER RAIL SUPPORT WITH LEVELER		3PCS
L	CENTER RAIL		1PC
M	BOTTOM CROSS BAR		3PCS
N	RAIL TOP		2PCS
HB	204390KW (B1) FROM BOX 1 HEADBOARD COMPLETE		1PC
D	204390KW (B1) FROM BOX 1 FOOTBOARD		1PC

B3 (BOX 3)

O	DRAWER BOX		2PCS
---	------------	---	------

B4 (BOX 4)

P	DRAWER BOX		2PCS
---	------------	---	------

ITEM: 204390KW (B1-B4)



ASSEMBLY INSTRUCTIONS

ASSEMBLY TIPS:

- 1 . Remove hardware from box and sort by size.
- 2 . Please check to see that all hardware and parts are present prior to start of assembly.
- 3 . Please follow attached instructions in the same sequence as numbered to assure fast & easy assembly.



WARNING !

- 1 . Don't attempt to repair or modify parts that are broken or defective. Please contact the store immediately.
- 2 . This product is for home use only and not intended for commercial establishment.

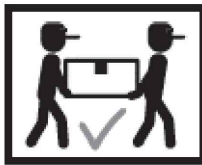





ASSEMBLY TIME







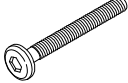

30 MINUTES

HARDWARE IDENTIFICATION

Z-B1 (BOX 1) - HARDWARE PACK IS LOCATED IN 204390KW (B1)

1	BOLT (M6 x 30mm - BLK)		6PCS	3	FLAT WASHER (1/4" x 13mm - BLK)		6PCS
2	LOCK WASHER (1/4" - BLK)		6PCS	4	ALLEN WRENCH (M4 x 65mm - BLK)		1PC

Z-B2 (BOX 2) - HARDWARE PACK IS LOCATED IN 204390KW (B2)

5	LONG BOLT (M6 x 50mm - BLK)		5PCS	9	LONG FLAT HEAD SCREW (M4 x 32mm - RBW)		43PCS
6	SHORT BOLT (M6 x 35mm - BLK)		8PCS	10	SHORT FLAT HEAD SCREW (M4 x 16mm - RBW)		4PCS
7	LOCK WASHER (1/4" - BLK)		8PCS	11	SMALL ALLEN WRENCH (M4 x 100mm - BLK)		1PC
8	FLAT WASHER (1/4" x 20mm - BLK)		8PCS	12	BIG ALLEN WRENCH (M5 x 65mm - BLK)		1PC

NOTE:

Philips head screw driver in the assembly process ; however, manufacturer does not provide the item

ITEM: 204390KW (B1-B4)

ASSEMBLY INSTRUCTIONS



STEP 1

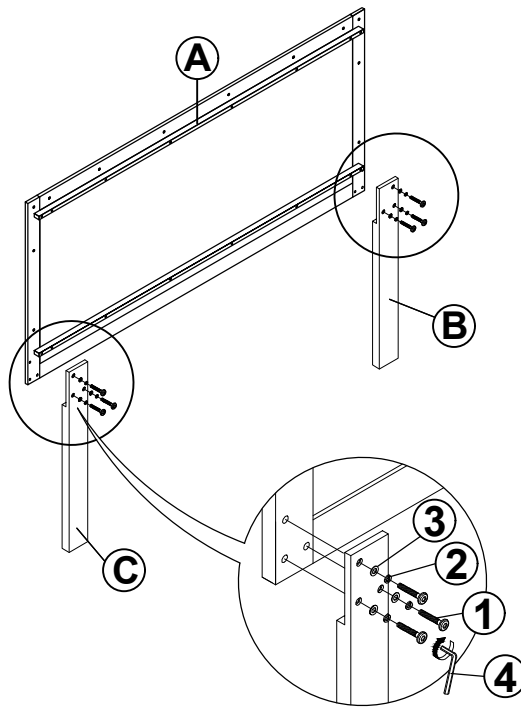

STEP 2

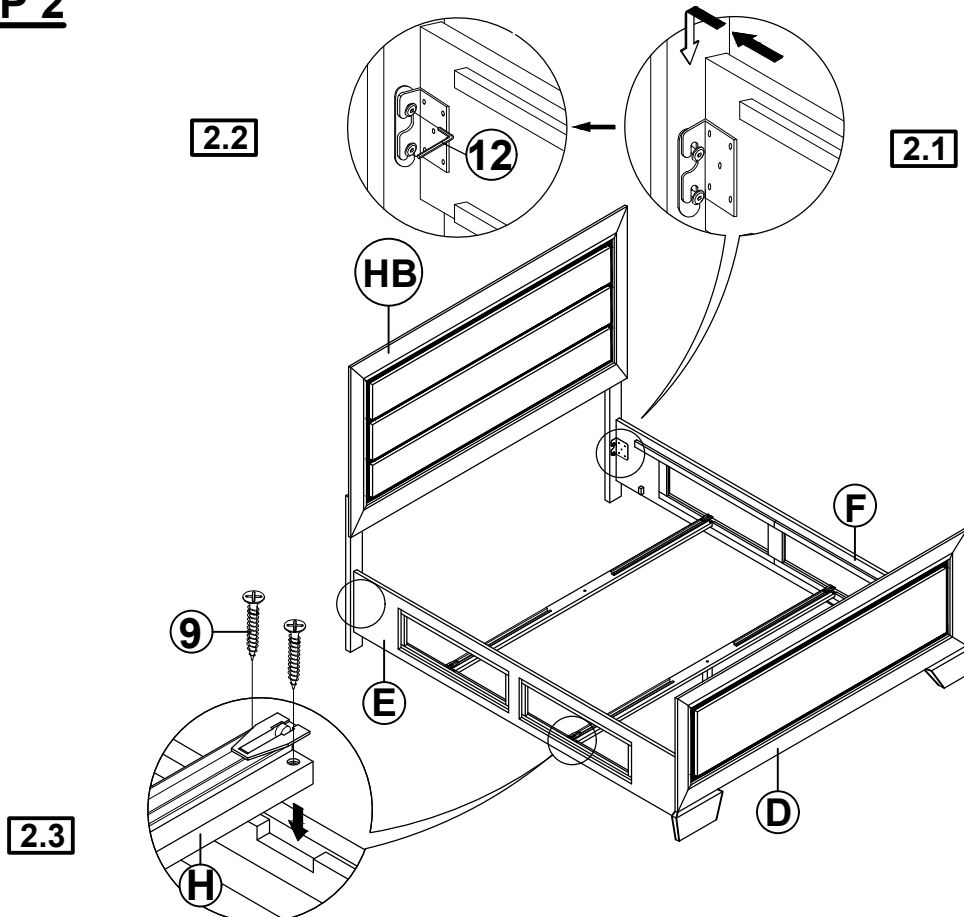

ITEM: 204390KW (B1-B4)

ASSEMBLY INSTRUCTIONS

STEP 3

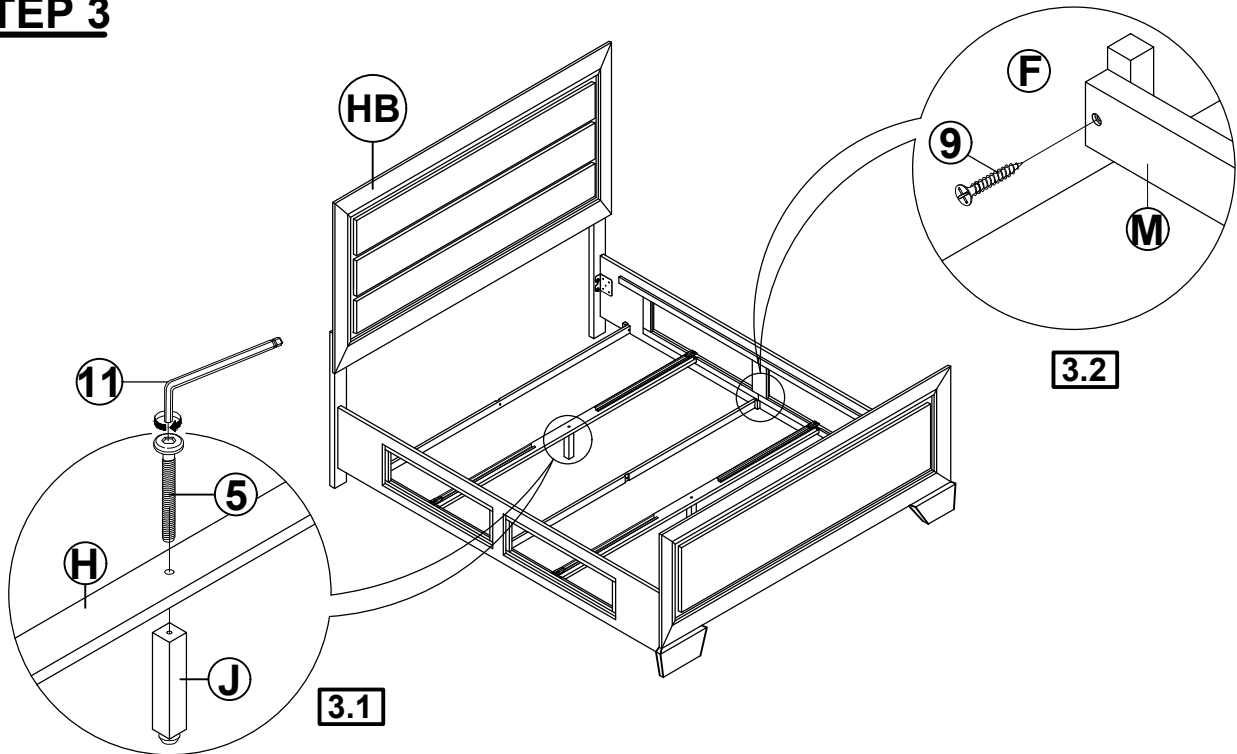

STEP 4

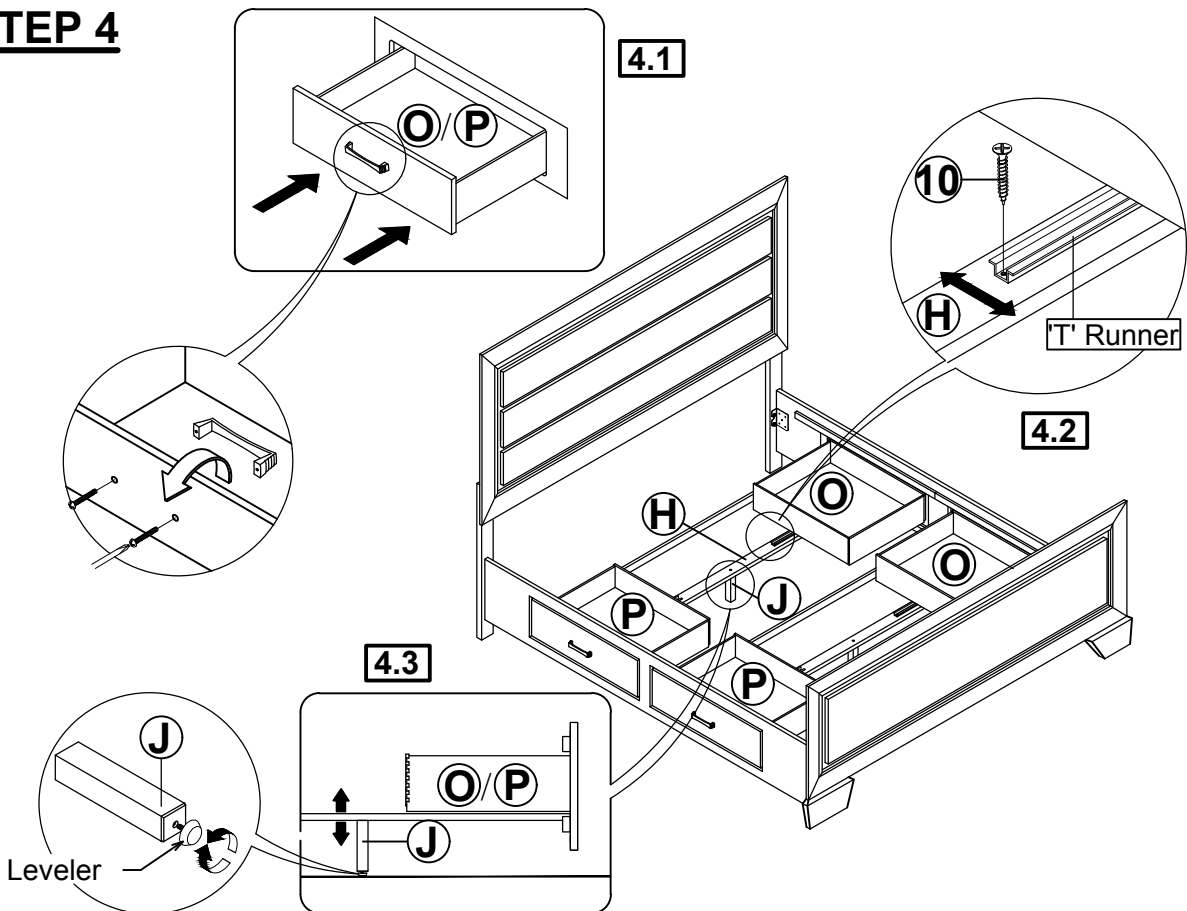

ITEM: **204390KW (B1-B4)**
ASSEMBLY INSTRUCTIONS



STEP 5

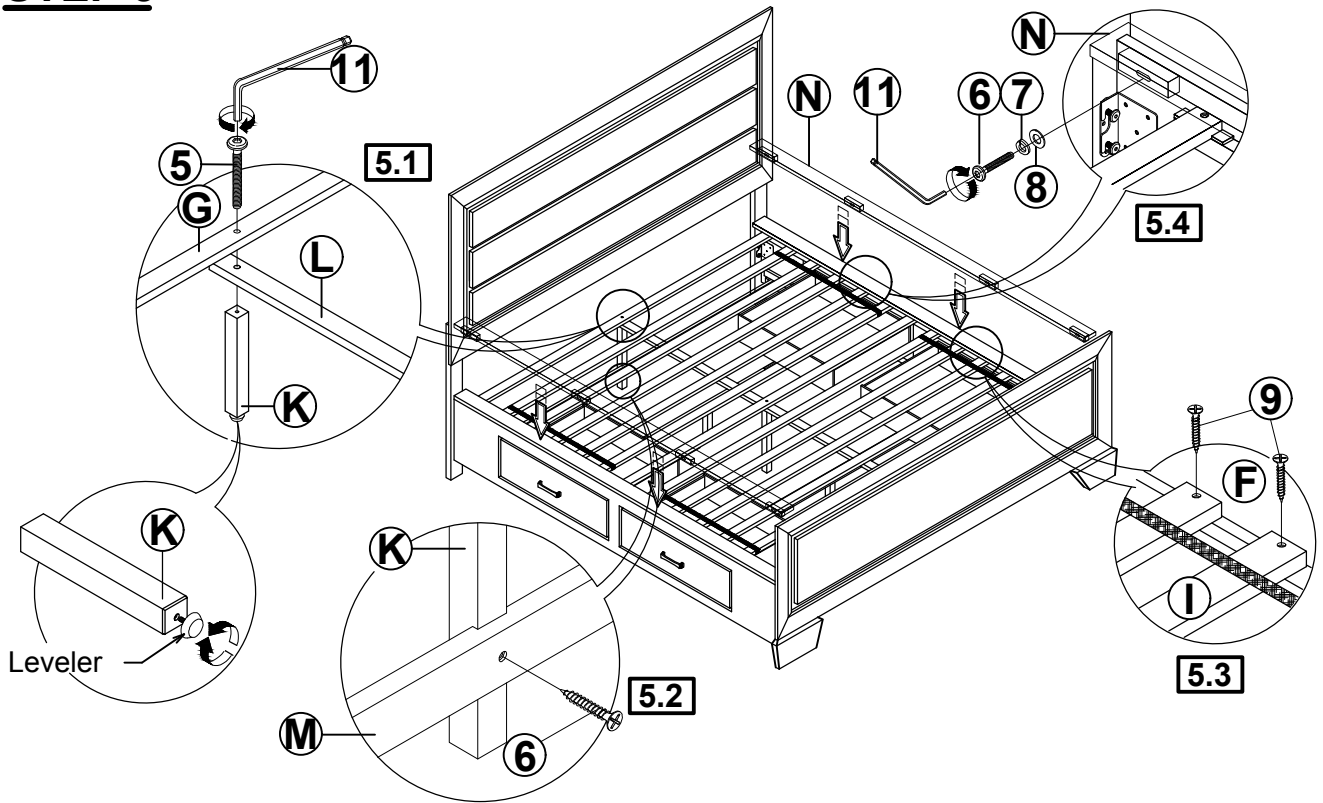

STEP 6
COMPLETE

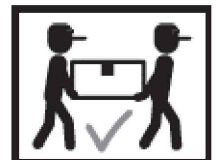
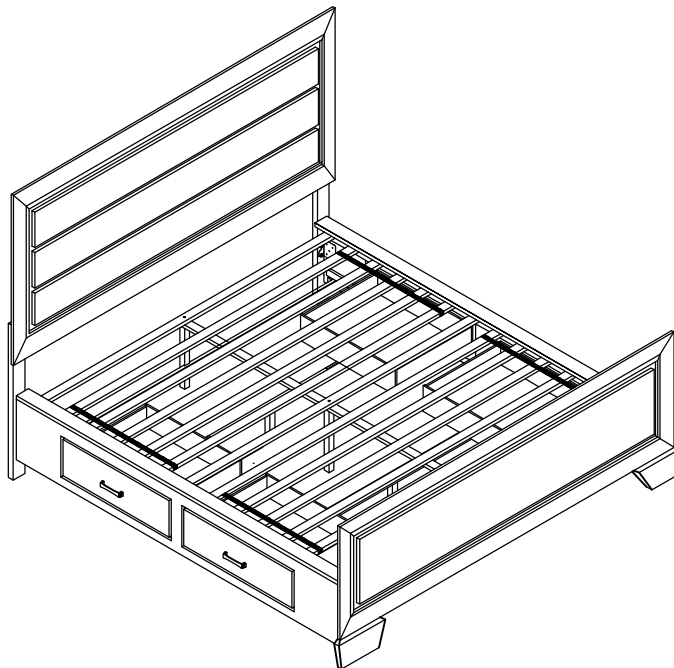

ITEM: 204390KW (B1-B4)



INNER SIZE : 76.57" X 86.61"

INNER SIZE DRAWER : 5.78" X 17.71" X 24.01"

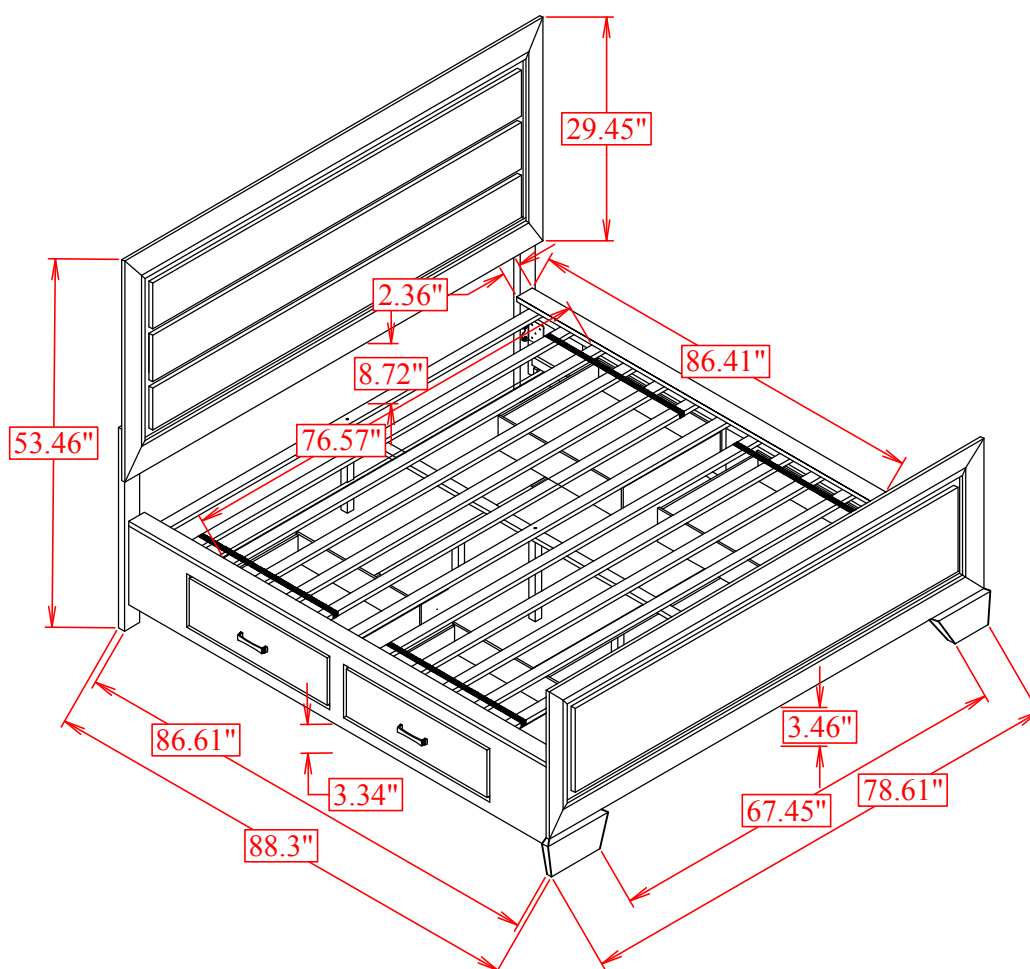

Note: Dimension tolerance $\pm 5\%$