

ASSEMBLY INSTRUCTIONS
COASTER FINE FURNITURE

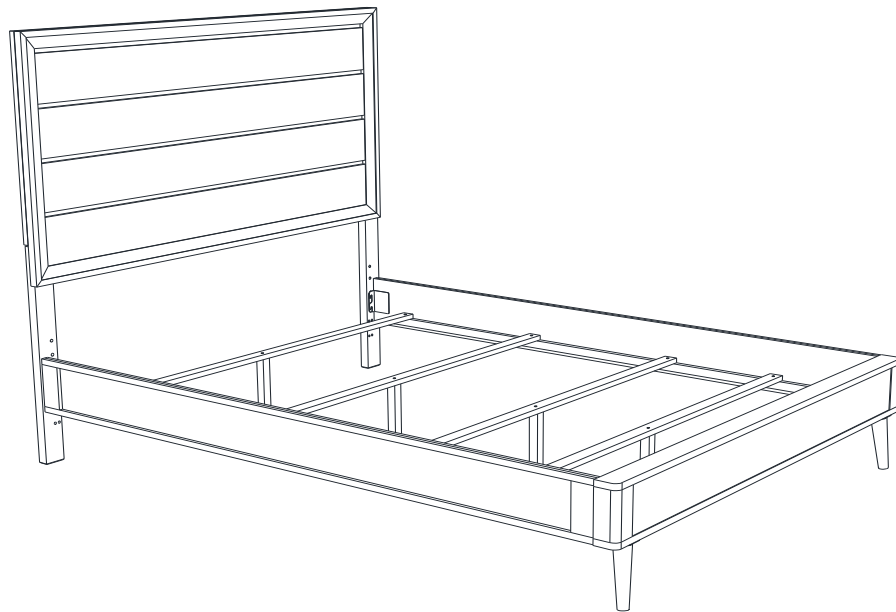

Fine Furniture for every stage of life

222701Q (B1&B2)
Queen Bed

REVISION 0 : 10/16/2018
REVISION 1 : 01/02/2019
REVISION 2 : 12/18/2020

ITEM: 222701Q (B1&B2)



ASSEMBLY INSTRUCTIONS

ASSEMBLY TIPS:

1. Remove hardware from box and sort by size.
2. Please check to see that all hardware and parts are present prior to start of assembly.
3. Please follow attached instructions in the same sequence as numbered to assure fast & easy assembly.



WARNING!

1. Don't attempt to repair or modify parts that are broken or defective. Please contact the store immediately.
2. This product is for home use only and not intended for commercial establishments.



ASSEMBLY TIME

20 MINUTES

PARTS IDENTIFICATION

B1 (BOX 1)

A	HEADBOARD PANEL		1PC
B	FOOTBOARD		1PC
C	RIGHT HEADBOARD LEG		1PC
D	LEFT HEADBOARD LEG		1PC
E	BED SLAT		4PCS
F	BED SLAT SUPPORT WITH LEVELER		4PCS
G	FOOTBOARD LEG		2PCS

B2 (BOX 2)

H	BED RAIL		2PCS
HB	222701Q(B1) FROM BOX 1 HEADBOARD COMPLETE		1PC
FB	222701Q(B1) FROM BOX 1 FOOTBOARD		1PC

ITEM: 222701Q (B1&B2)

ASSEMBLY INSTRUCTIONS

ASSEMBLY TIPS:

1. Remove hardware from box and sort by size.
2. Please check to see that all hardware and parts are present prior to start of assembly.
3. Please follow attached instructions in the same sequence as numbered to assure fast & easy assembly.









WARNING!

1. Don't attempt to repair or modify parts that are broken or defective. Please contact the store immediately.
2. This product is for home use only and not intended for commercial establishments.

HARDWARE IDENTIFICATION

Z-B1 (BOX 1) - HARDWARE PACK IS LOCATED IN 222701Q (B1)

1	BOLT (M6 x 30mm - BLK)		6PCS
2	LOCK WASHER (1/4" - BLK)		6PCS
3	FLAT WASHER (1/4"ID x 13mm - BLK)		6PCS
4	SMALL ALLEN WRENCH (M4 x 60mm - BLK)		1PC
5	BIG ALLEN WRENCH (M5 x 65mm - BLK)		1PC
6	FLAT HEAD SCREW (M4 x 32mm - RBW)		8PCS

NOTE:

Phillips head screw driver is required in the assembly process; however, manufacturer does not provide this item.

ASSEMBLY INSTRUCTIONS

STEP 1

****BACK VIEW****

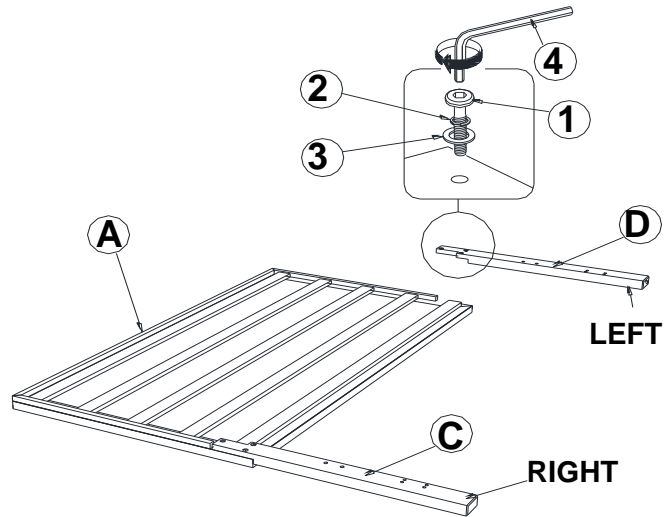

Note : Please put item on soft surface.

STEP 2

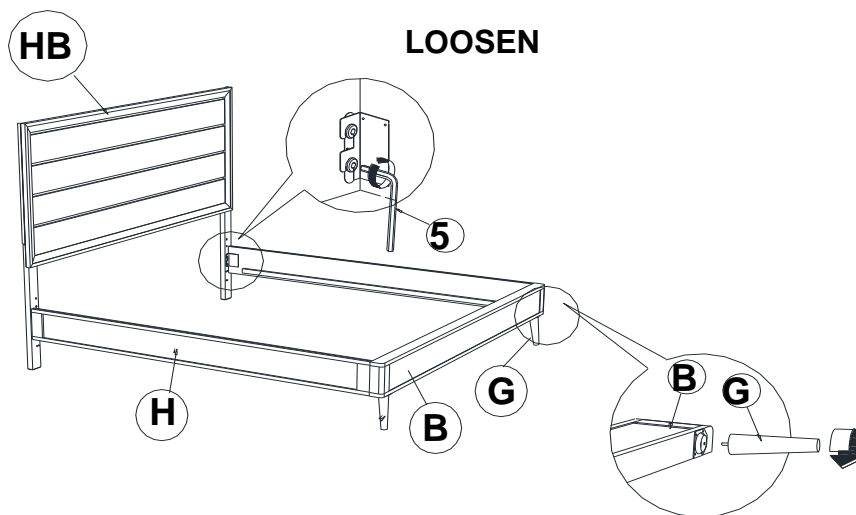

STEP 3

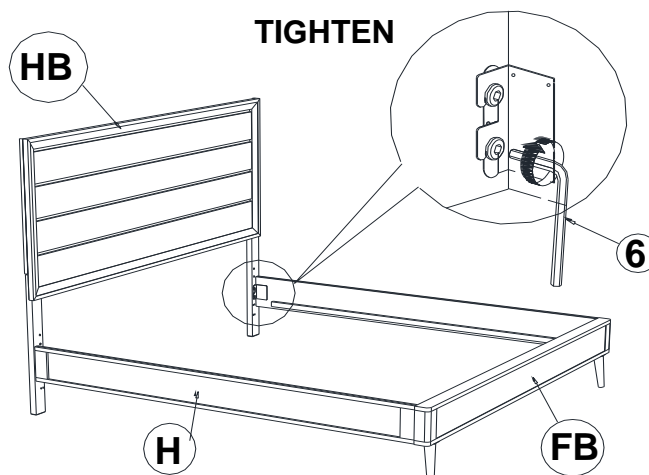

ASSEMBLY INSTRUCTIONS

STEP 4

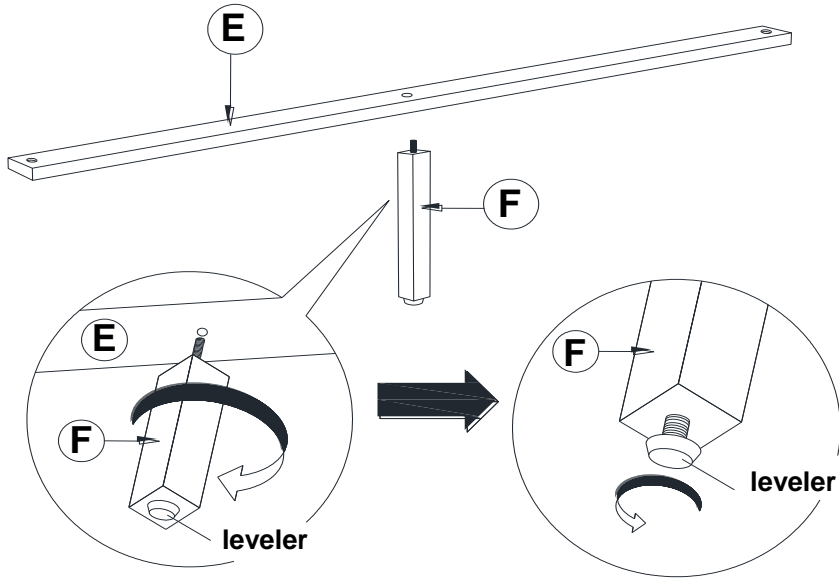

STEP 5

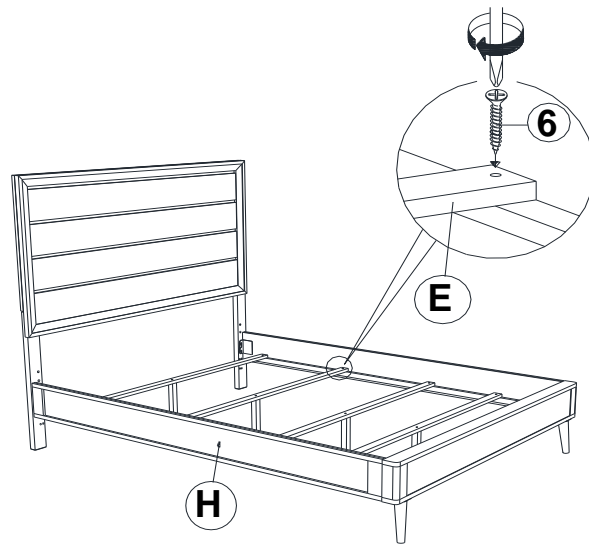

STEP 6
COMPLETE

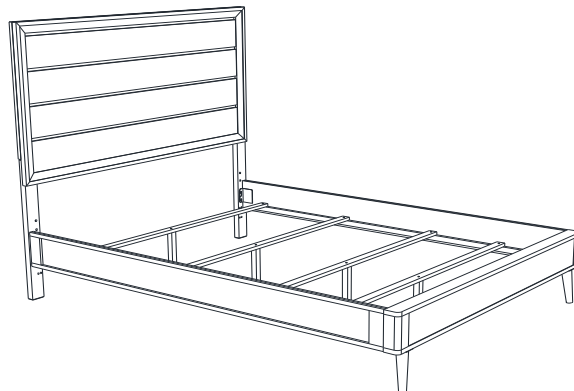

ITEM: 222701Q (B1&B2)



INNER SIZE: 60.8" x 81"

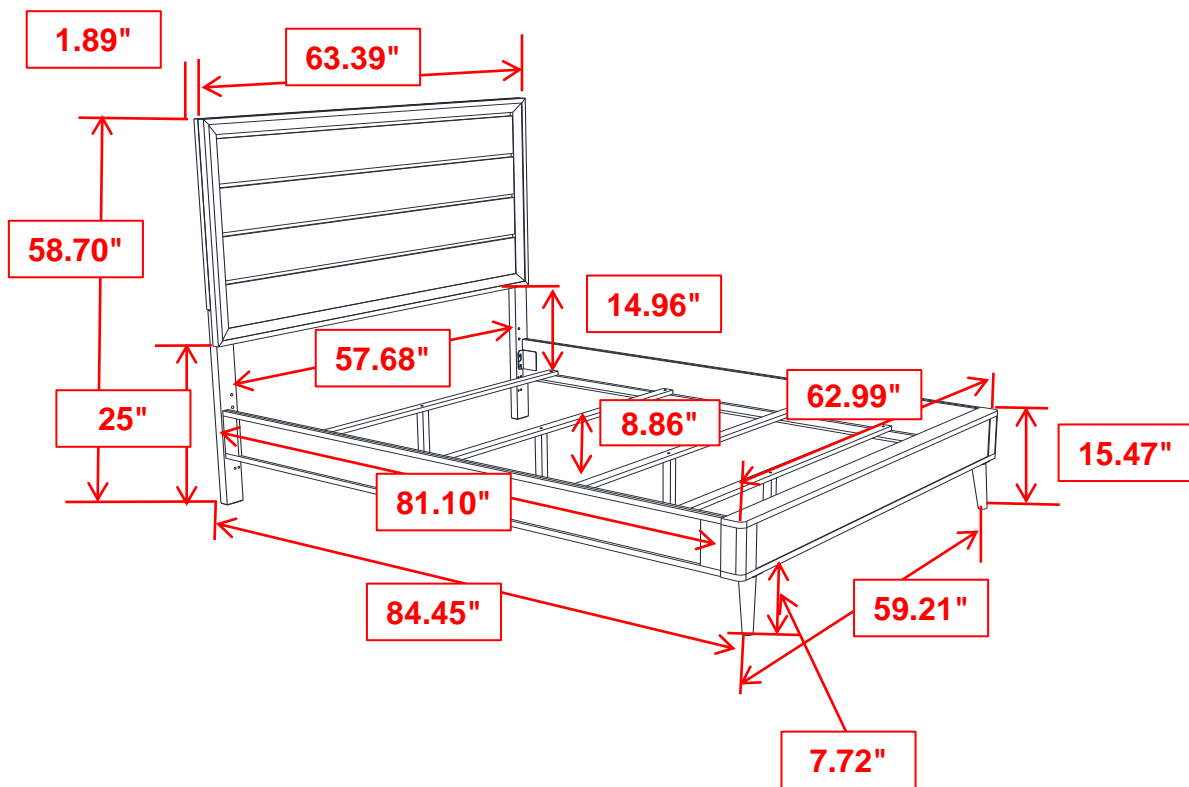

Note : Dimension tolerance $\pm 5\%$