



## ASSEMBLY INSTRUCTIONS COASTER FINE FURNITURE



*Fine Furniture for every stage of life*

# 204391Q (B1&B2) *Queen Bed*

REVISION 0 : 10/30/2015  
REVISION 1 : 01/21/2020

PAGE 1 OF 5

COASTERFURNITURE.COM

# ITEM: 204391Q (B1&B2)



## ASSEMBLY INSTRUCTIONS

### ASSEMBLY TIPS:

- 1 . Remove hardware from box and sort by size.
- 2 . Please check to see that all hardware and parts are present prior to start of assembly.
- 3 . Please follow attached instructions in the same sequence as numbered to assure fast & easy assembly.



### WARNING !

- 1 . Don't attempt to repair or modify parts that are broken or defective. Please contact the store immediately.
- 2 . This product is for home use only and not intended for commercial establishment.





ASSEMBLY TIME

30 MINUTES

## PARTS IDENTIFICATION

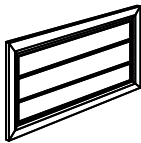
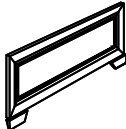
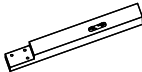
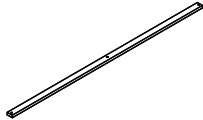
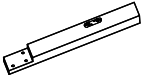
### B1 (BOX 1)

A	HEADBOARD PANEL		1PC	D	FOOTBOARD		1PC
B	RIGHT HEADBOARD LEG		1PC	E	BED SLAT		4PCS
C	LEFT HEADBOARD LEG		1PC	F	BED SLAT SUPPORT WITH LEVELER		4PCS

### B2 (BOX 2)

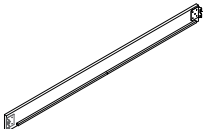
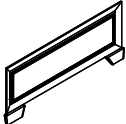
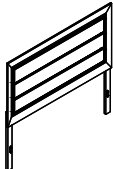
G	BED RAIL		2PCS	D	204391Q (B1) (FROM BOX 1) FOOTBOARD		1PC
HB	204391Q (B1) (FROM BOX 1) HEADBOARD COMPLETE		1PC				

# ITEM: 204391Q (B1&B2)



## ASSEMBLY INSTRUCTIONS

### ASSEMBLY TIPS:

- 1 . Remove hardware from box and sort by size.
- 2 . Please check to see that all hardware and parts are present prior to start of assembly.
- 3 . Please follow attached instructions in the same sequence as numbered to assure fast & easy assembly.



### WARNING !

- 1 . Don't attempt to repair or modify parts that are broken or defective. Please contact the store immediately.
- 2 . This product is for home use only and not intended for commercial establishment.

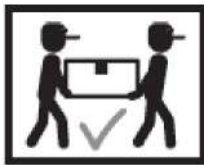





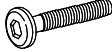

ASSEMBLY TIME

30 MINUTES

## HARDWARE IDENTIFICATION

### Z-B1 (BOX1) - HARDWARE PACK IS LOCATED IN 204391Q (B1)

1	<b>BOLT</b> (M6 x30mm - BLK)		6PCS	4	<b>FLAT HEAD SCREW</b> (M4 x 32mm - RBW)		8PCS
2	<b>LOCK WASHER</b> (1/4" - BLK)		6PCS	5	<b>SMALL ALLEN WRENCH</b> (M4 x 65mm - BLK)		1PC
3	<b>FLAT WASHER</b> (1/4" x13mm - BLK)		6PCS	6	<b>BIG ALLEN WRENCH</b> (M5 x 65mm - BLK)		1PC

### NOTE:

Philips head screw driver in the assembly process ; however, manufacturer does not provide the item

# ITEM: 204391Q (B1&B2)

## ASSEMBLY INSTRUCTIONS



### STEP 1

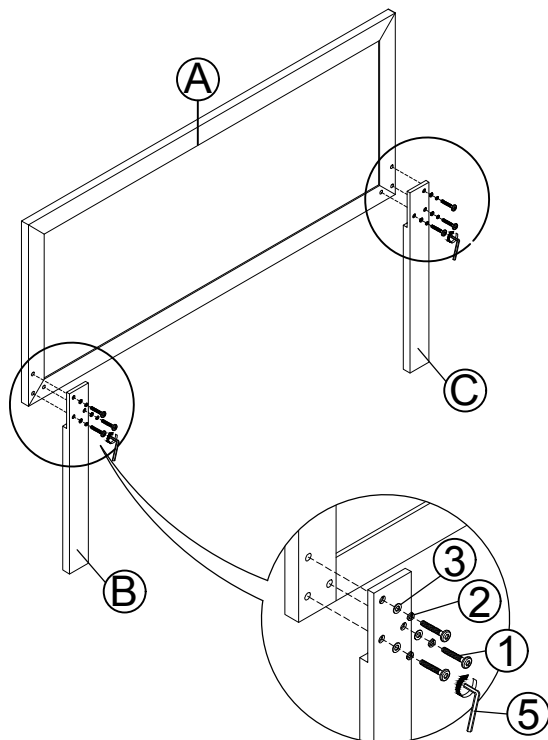

### STEP 2

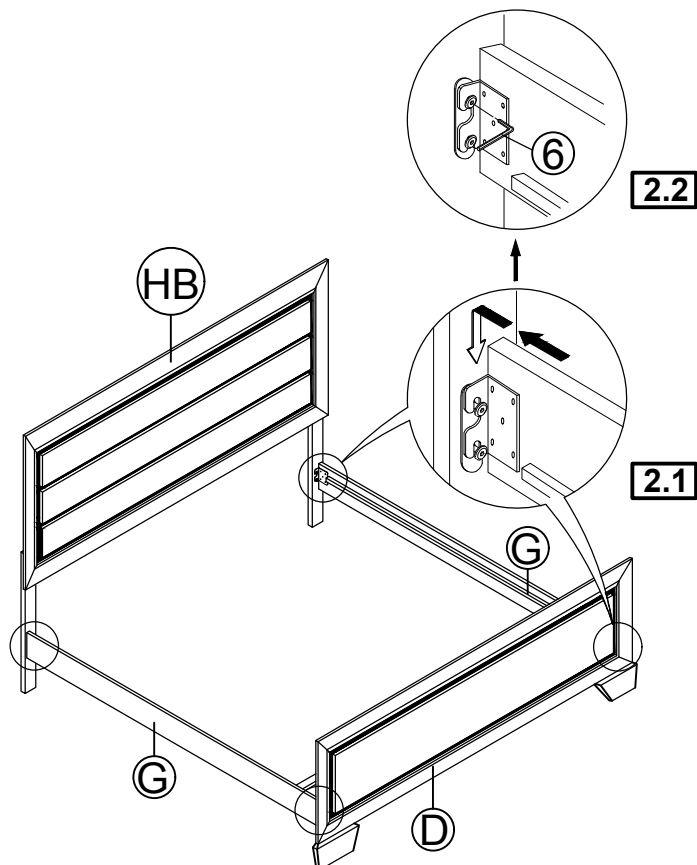

# ITEM: 204391Q (B1&B2)

## ASSEMBLY INSTRUCTIONS



### STEP 3

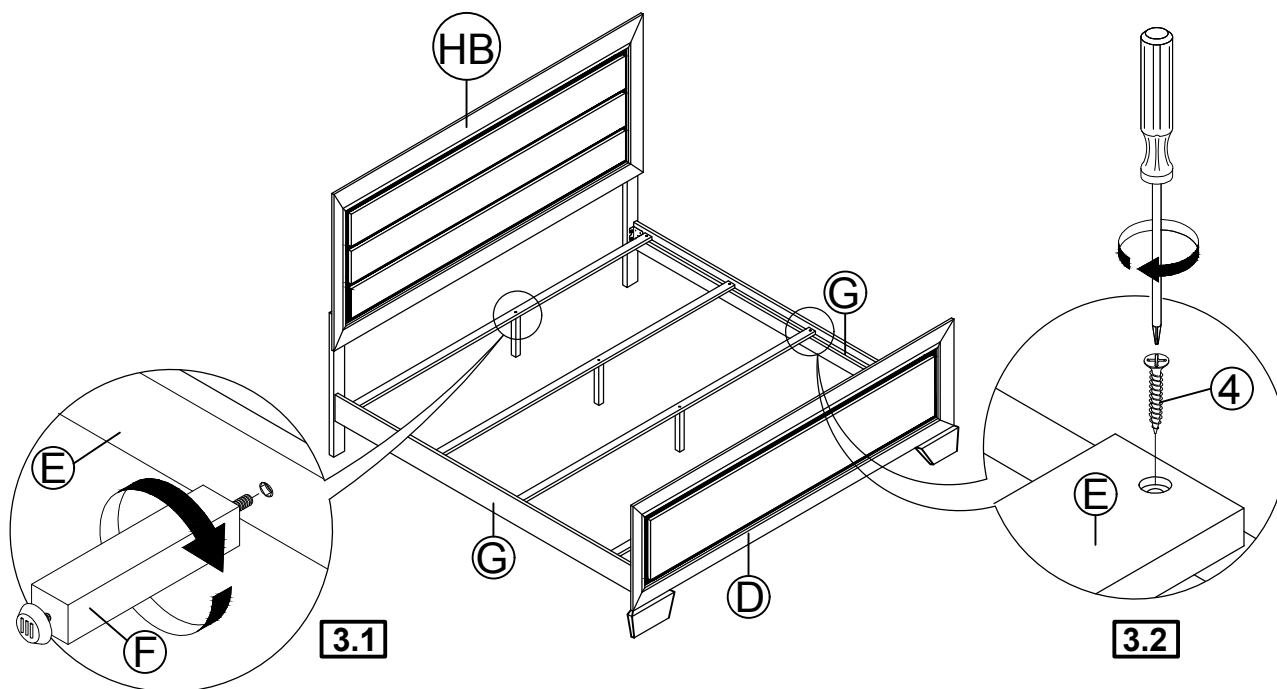

### STEP 4

## COMPLETE

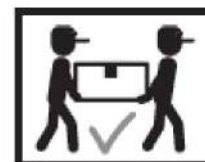
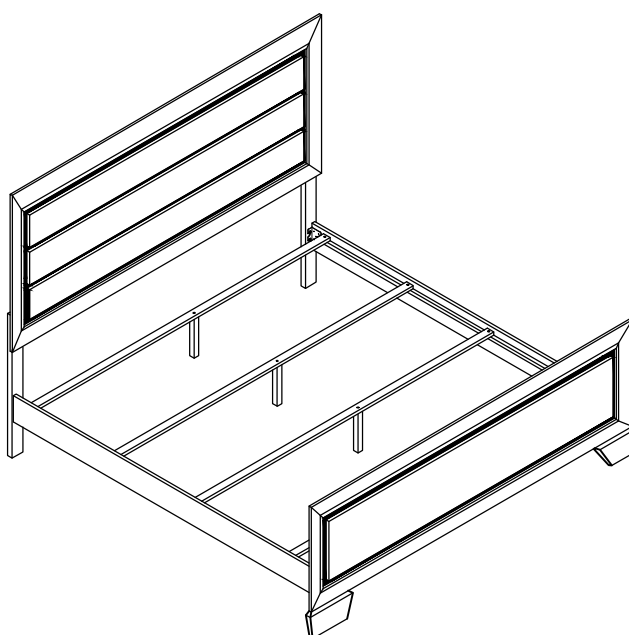

ITEM: **204391Q (B1&B2)**



**INNER SIZE : 62.32" X 81.10"**

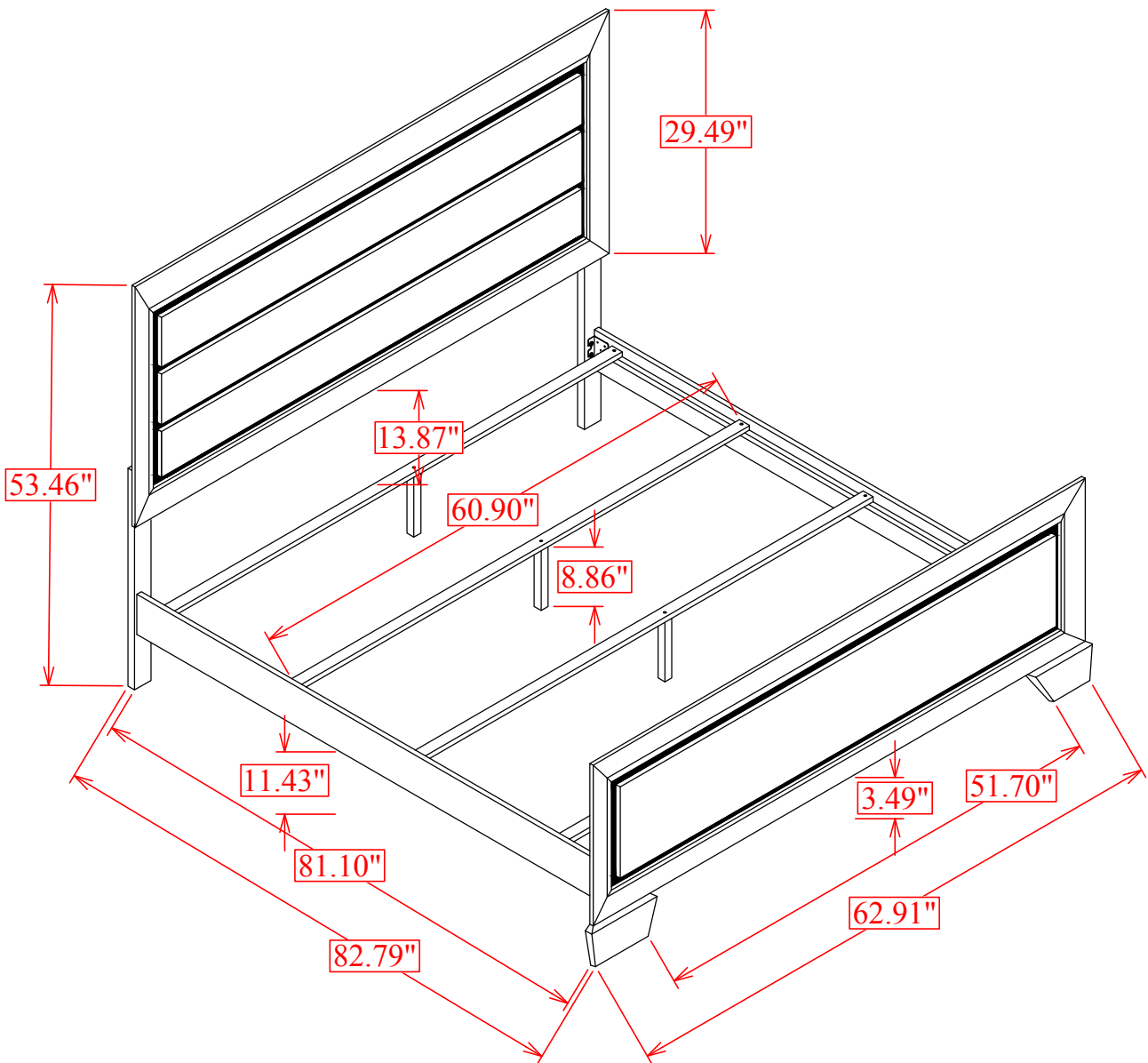

**Note:**Dimension tolerance  $\pm 5\%$