

ASSEMBLY INSTRUCTIONS

COASTER FINE FURNITURE

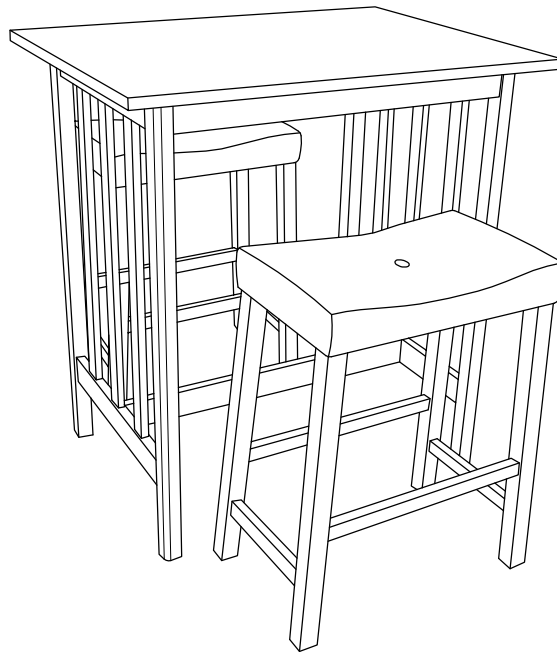

Fine Furniture for every stage of life

130004
3Pc Counter Height Set

REVISION 0: 01/28/2011
REVISION 1: 10/24/2011
REVISION 2: 07/06/2012
REVISION 3: 03/06/2015
REVISION 4: 11/13/2020

ITEM: 130004

ASSEMBLY INSTRUCTIONS

ASSEMBLY TIPS :

1. Remove hardware from box and sort by size.
2. Please check to see that all hardware and parts are present prior to start of assembly.
3. Please follow attached instructions in the same sequence as numbered to assure fast & easy assembly.



WARNING !

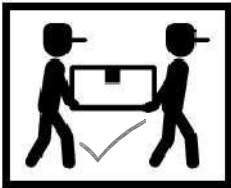

1. Don't attempt to repair or modify parts that are broken or defective. Please contact the store immediately.
2. This product is for home use only and not intended for commercial establishments.



ASSEMBLY TIME

45 MINUTES

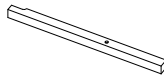
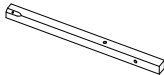
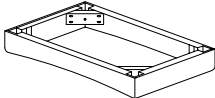
PARTS IDENTIFICATION

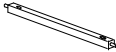
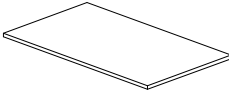
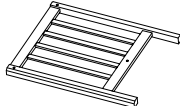
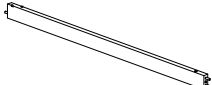
A	LEFT CHAIR LEG (MARK WITH '1')		4PCS
B	RIGHT CHAIR LEG (MARK WITH '2')		4PCS
C	SEAT CUSHION WITH FRAME		2PCS
D	LONG STRETCHER		4PCS
E	SHORT STRETCHER		4PCS
F	TABLE TOP		1PC
G	TABLE LEG FRAME		2PCS
H	TRESTLE BAR		1PC

ITEM : 130004

ASSEMBLY INSTRUCTIONS

ASSEMBLY TIPS :









1. Remove hardware from box and sort by size.
2. Please check to see that all hardware and parts are present prior to start of assembly.
3. Please follow attached instructions in the same sequence as numbered to assure fast & easy assembly.



WARNING !

1. Don't attempt to repair or modify parts that are broken or defective. Please contact the store immediately.
2. This product is for home use only and not intended for commercial establishments.

HARDWARE IDENTIFICATION

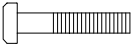
1	ALLEN WRENCH (M4 x 63MM - BLK)		1PC
2	LONG BOLT (M6 x 60mm - RBW)		6PCS
3	BARREL NUT (M6 x 9.5 x 14mm)		6PCS
4	LOCK WASHER (1/4" - BLK)		8PCS
5	FLAT WASHER (5/16" - RBW)		8PCS
6	WOOD PLUG (Ø14.5 x9MM)		6PCS
7	PAN HEAD SCREW (#8 X 1 1/2" - BLK)		16PCS
8	WOOD DOWEL (M8 x 30mm)		12PCS
9	SHORT BOLT (M6 x 50mm - RBW)		8PCS

NOTE :

Phillips head screw driver is required in the assembly process. However, manufacturer does not provide this item.

ITEM: **130004**

ASSEMBLY INSTRUCTIONS

STEP 1

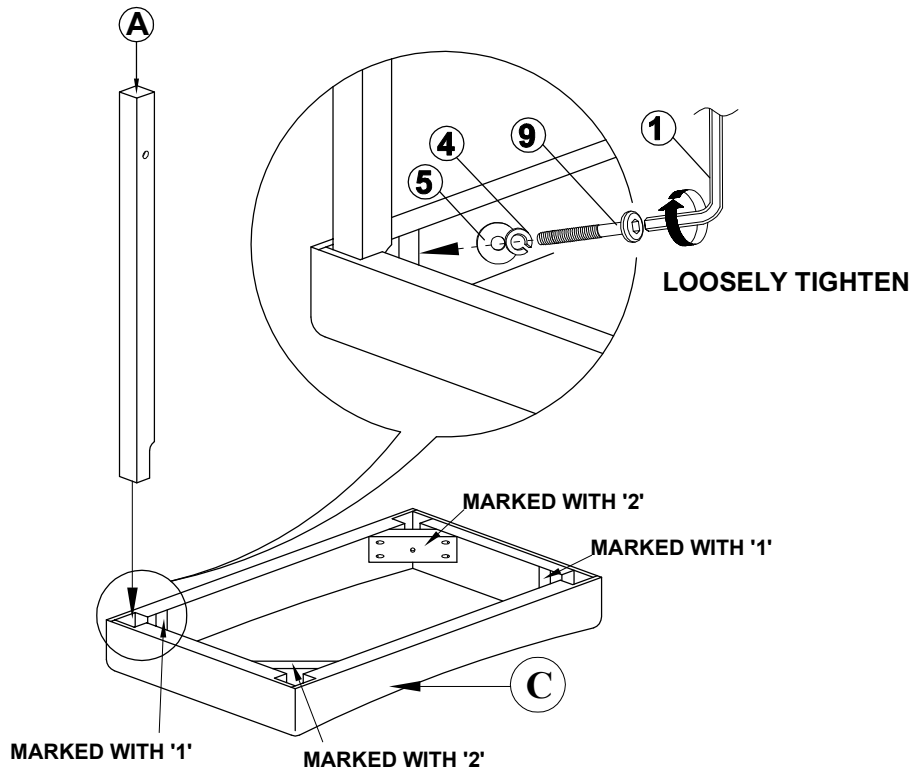

STEP 2

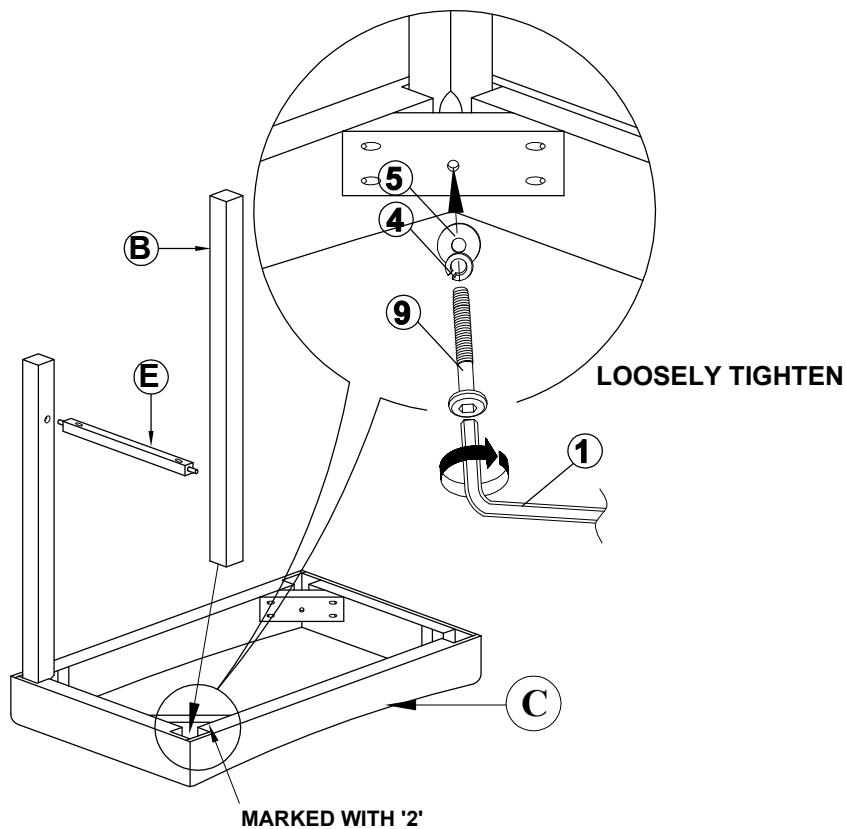

ITEM: **130004**

ASSEMBLY INSTRUCTIONS

STEP 3

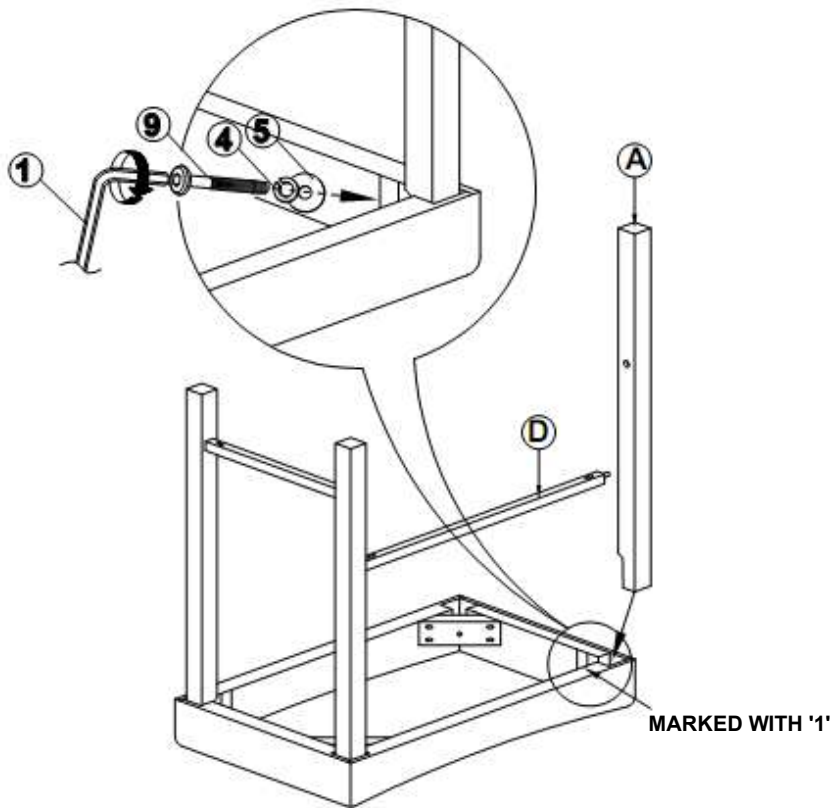

STEP 4

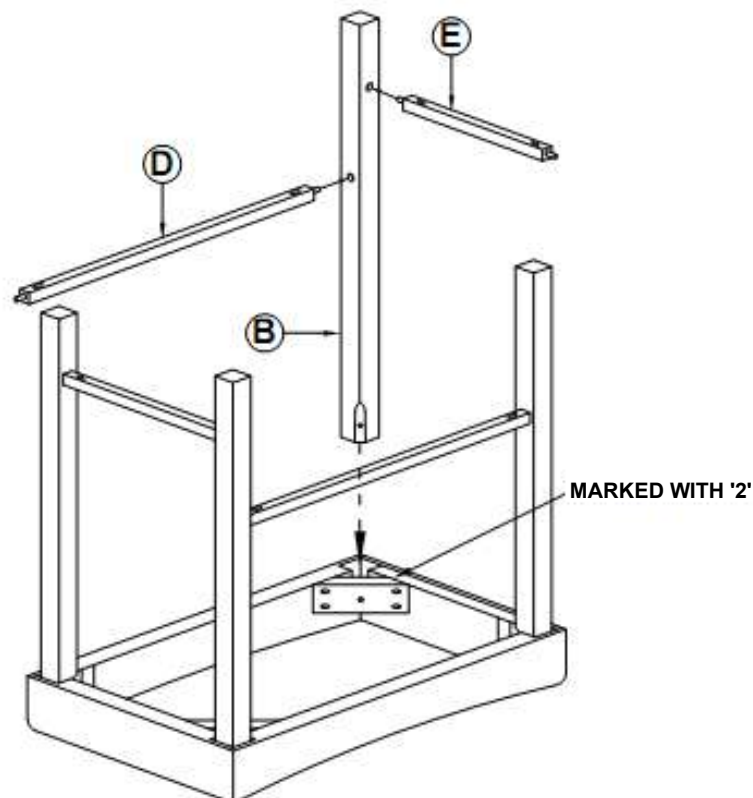

ITEM: **130004**

ASSEMBLY INSTRUCTIONS

STEP 5

Tighten all short bolts (from step 1 to 4) with Allen wrench

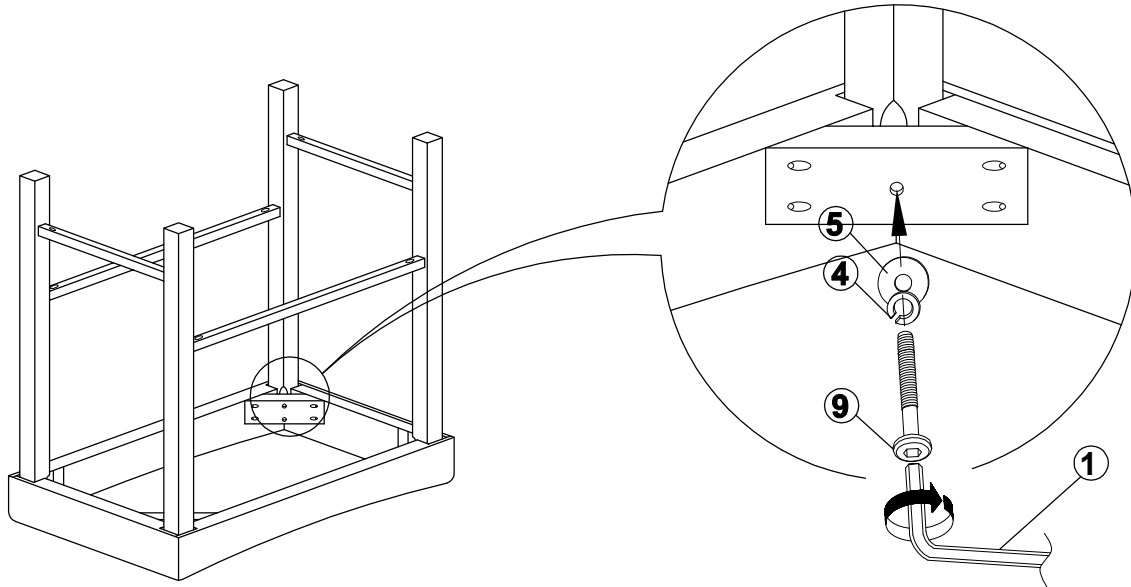

STEP 6

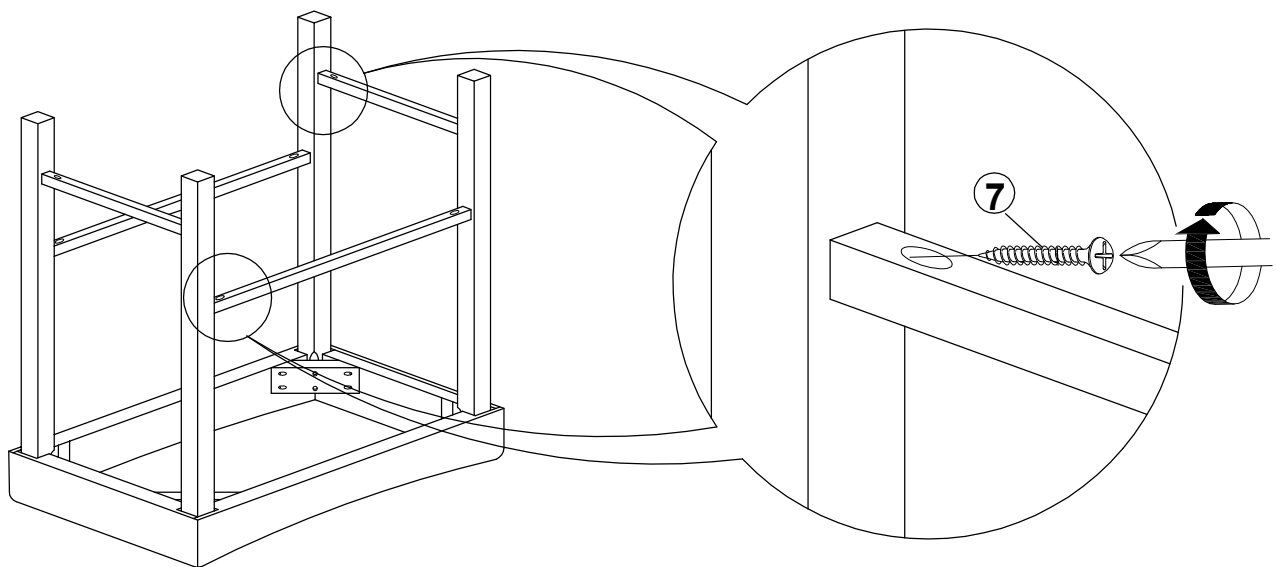

ITEM: **130004**

ASSEMBLY INSTRUCTIONS



STEP 7

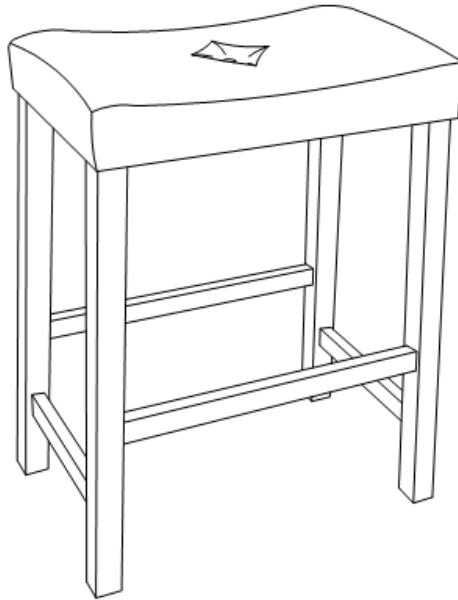

STEP 8

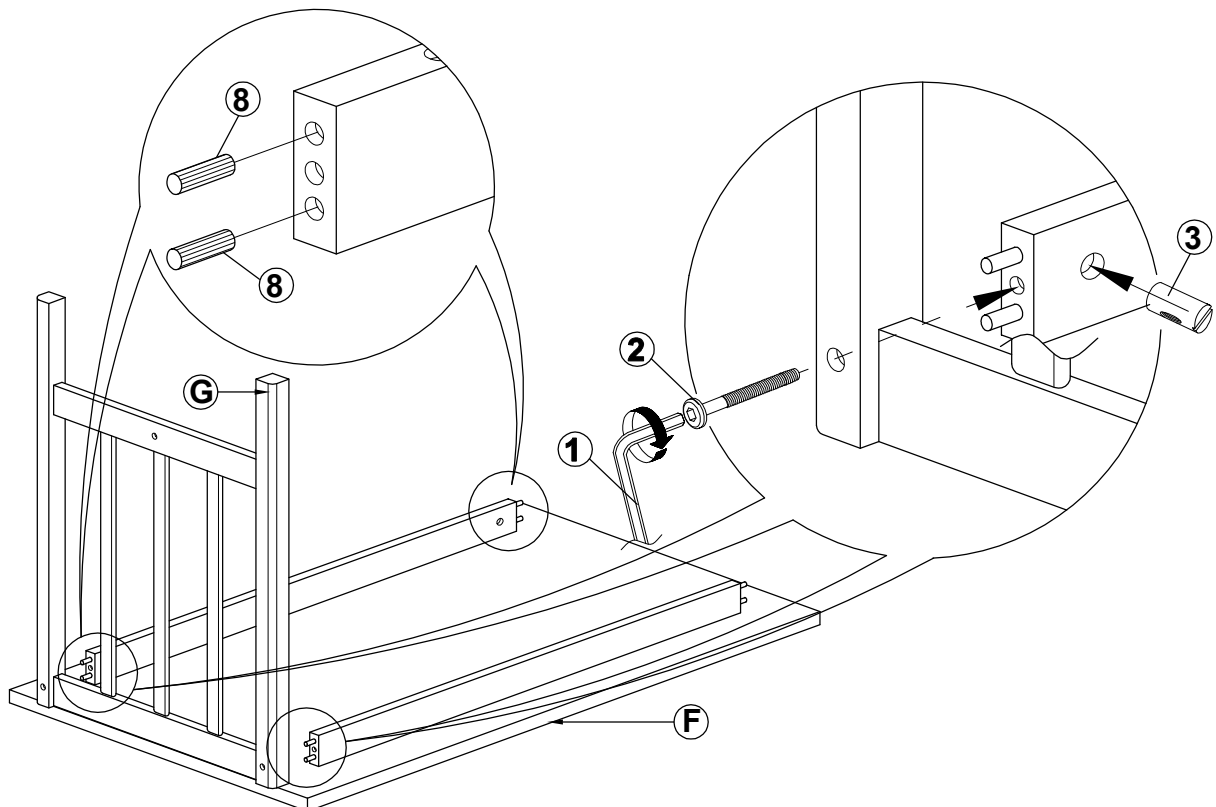

ITEM: **130004**

ASSEMBLY INSTRUCTIONS

STEP 9

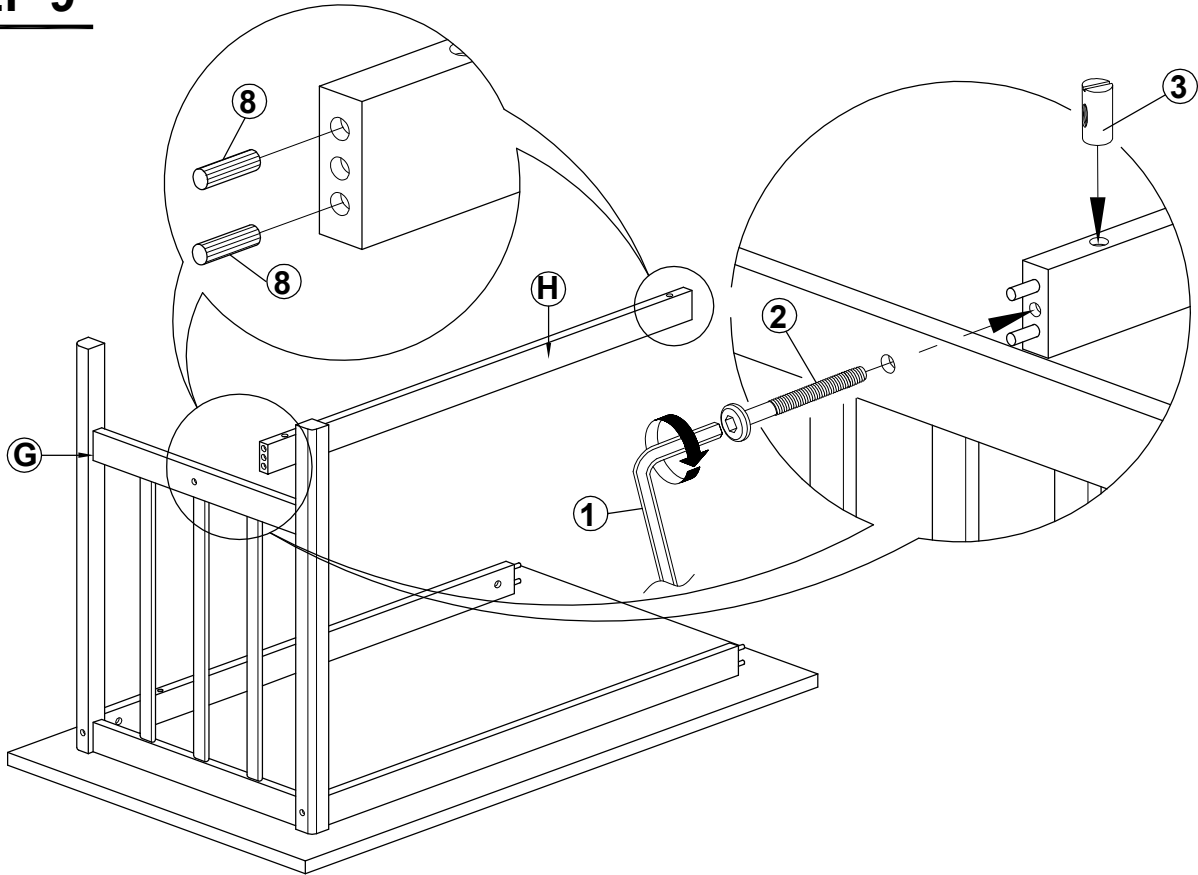

STEP 10

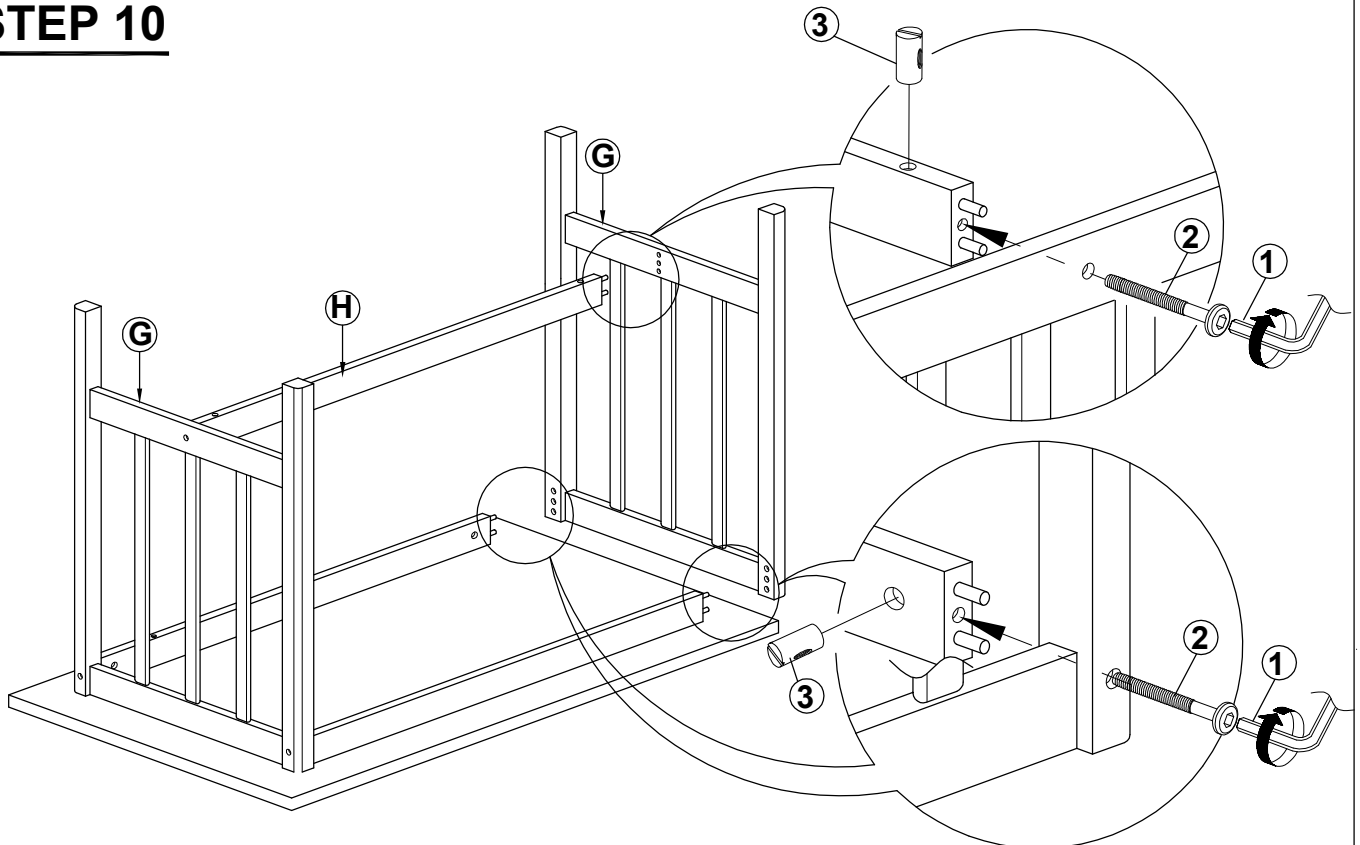

ITEM: **130004**



ASSEMBLY INSTRUCTIONS

STEP 11

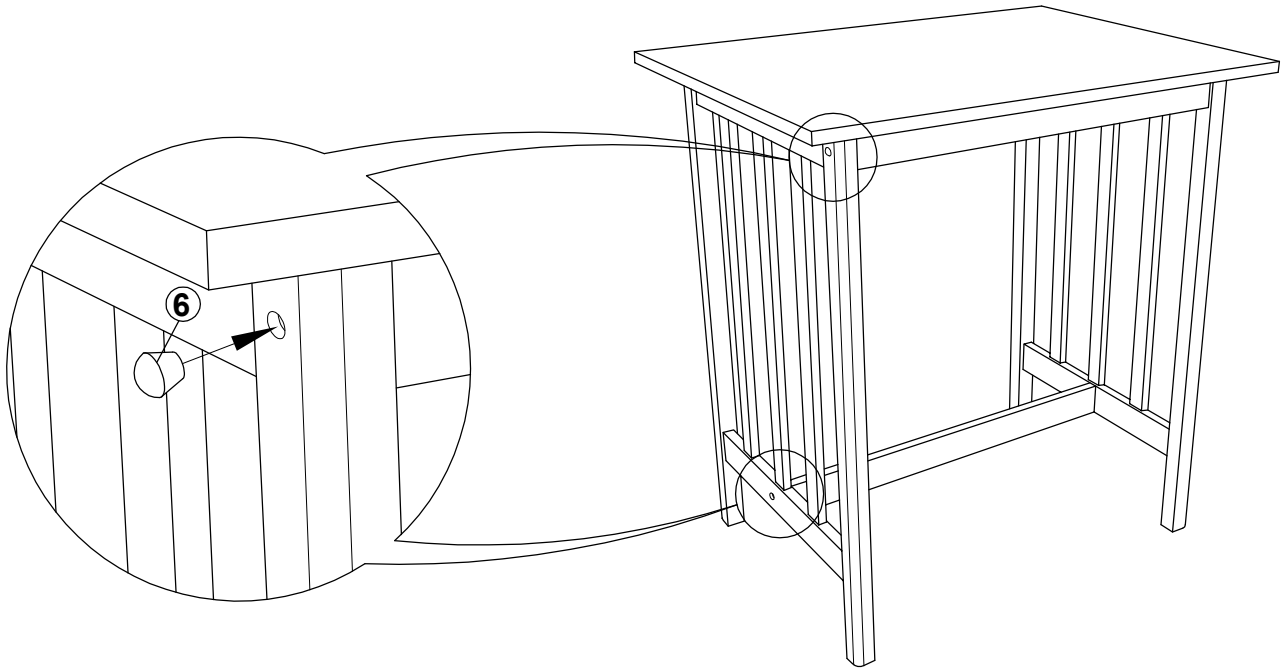

STEP 12
COMPLETE

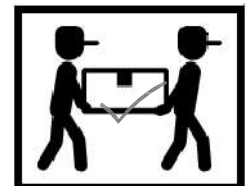
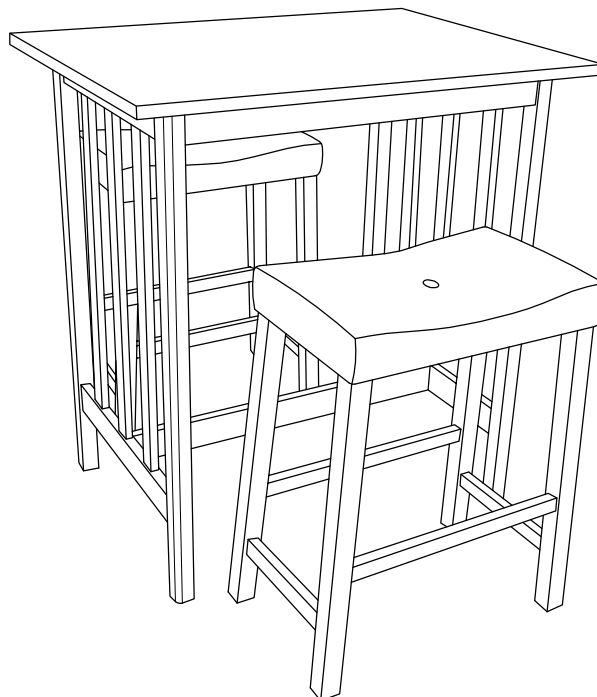

ITEM: 130004

COASTER
FINE FURNITURE

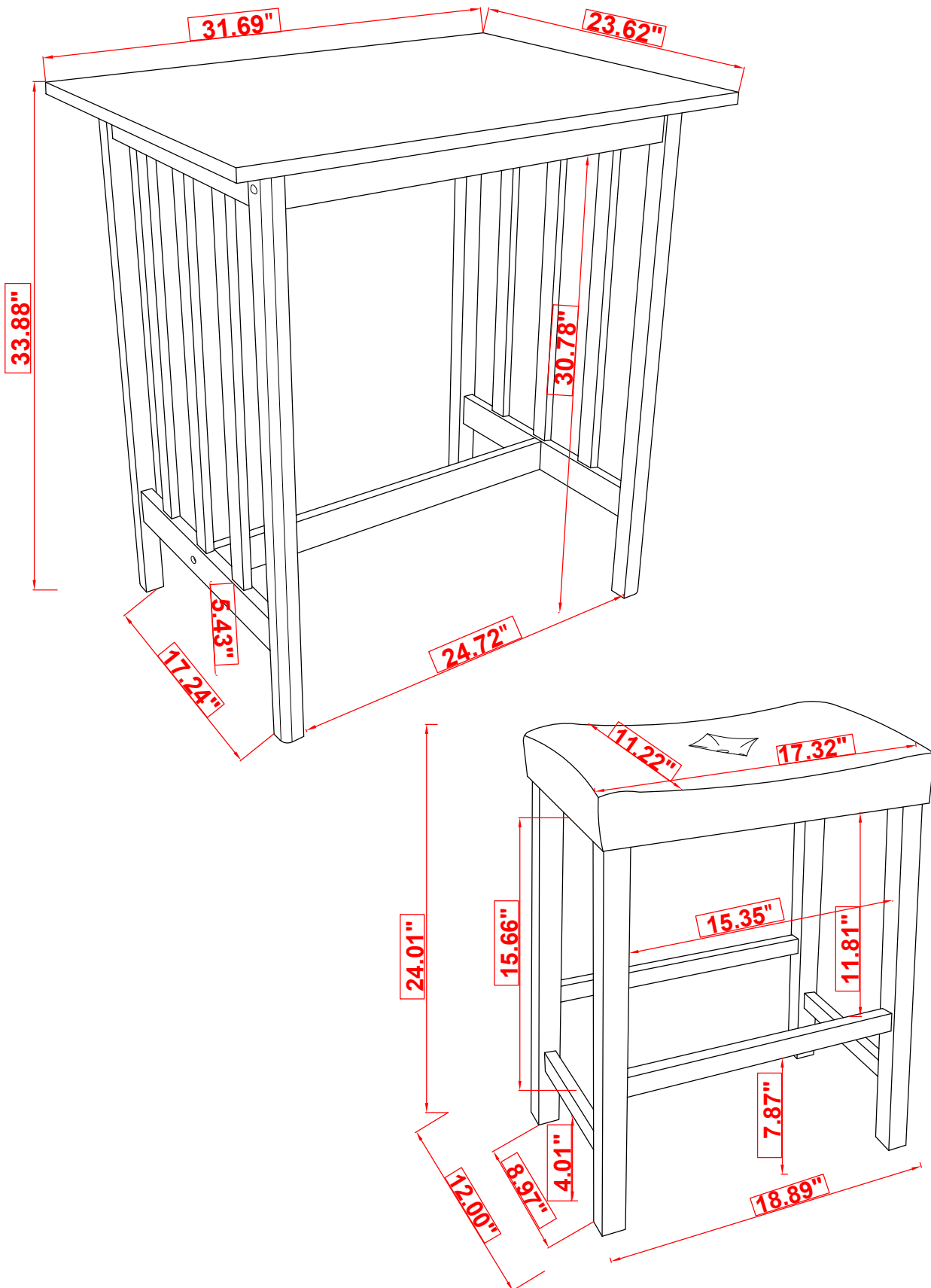

Note : Dimension tolerance $\pm 5\%$

COASTERFURNITURE.COM