

ASSEMBLY INSTRUCTION
COASTER FINE FURNITURE



Fine Furniture for every stage of life

100173(B1-B2)
BAR UNIT

REVISION 7/15/2011
REVISION 11/1/2011
REVISION 5/24/2019

ITEM: 100173



ASSEMBLY INSTRUCTIONS

ASSEMBLY TIPS:

1. Remove hardware from box and sort by size.
2. Please check to see that all hardware and parts are present prior to start of assembly.
3. Please follow attached instructions in the same sequence as numbered to assure fast & easy assembly.



Warning!

1. Don't attempt to repair or modify parts that are broken or defective. Please contact the store immediately.
2. This product is for home use only and not intended for commercial establishments.



ASSEMBLY TIME

25 MINUTES

PARTS IDENTIFICATION

A TOP

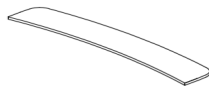

1PC

C FOOT REST



1PC

B BASE

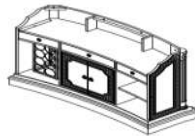

1PCS

D FOOT REST SUPPORT



3PCS

HARDWARE IDENTIFICATION

1 WRENCH
4mm



1PC

2 LONG BOTL
1/4"×20mm



6PCS

3 SHORT BOLT
1/4"×45mm



4PCS

4 LOCK WASHER
1/4"×19mm×1.5mm



10PCS

5 SHORT BOLT
1/4"×1-1/8"



10PCS

NOTE :

PHILLIPS HEAD SCREW DRIVER IS REQUIRED IN THE ASSEMBLY PROCESS;HOWEVER, MANUFACTURER DOES NOT PROVIDE THIS ITEM.

ITEM: 100173

ASSEMBLY INSTRUCTIONS

STEP 1

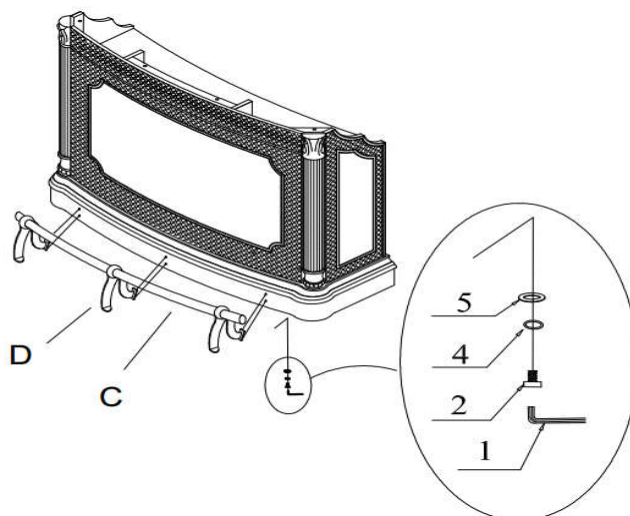

STEP 2

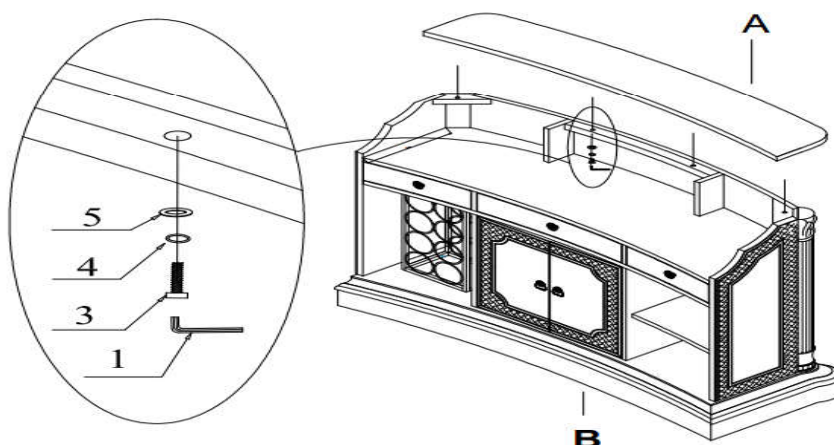

STEP 3

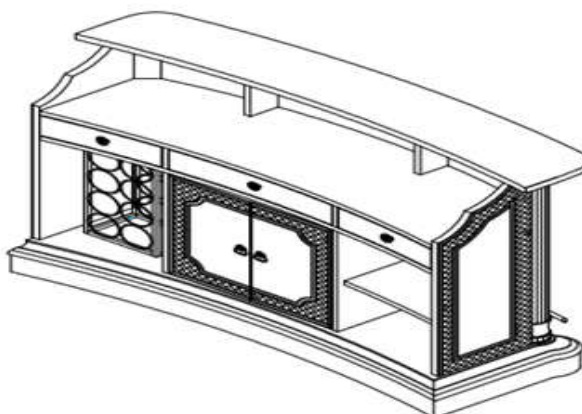

NOTE :

PHILLIPS HEAD SCREW DRIVER IS REQUIRED IN THE ASSEMBLY PROCESS; HOWEVER, MANUFACTURER DOES NOT PROVIDE THIS ITEM.

ITEM:100173

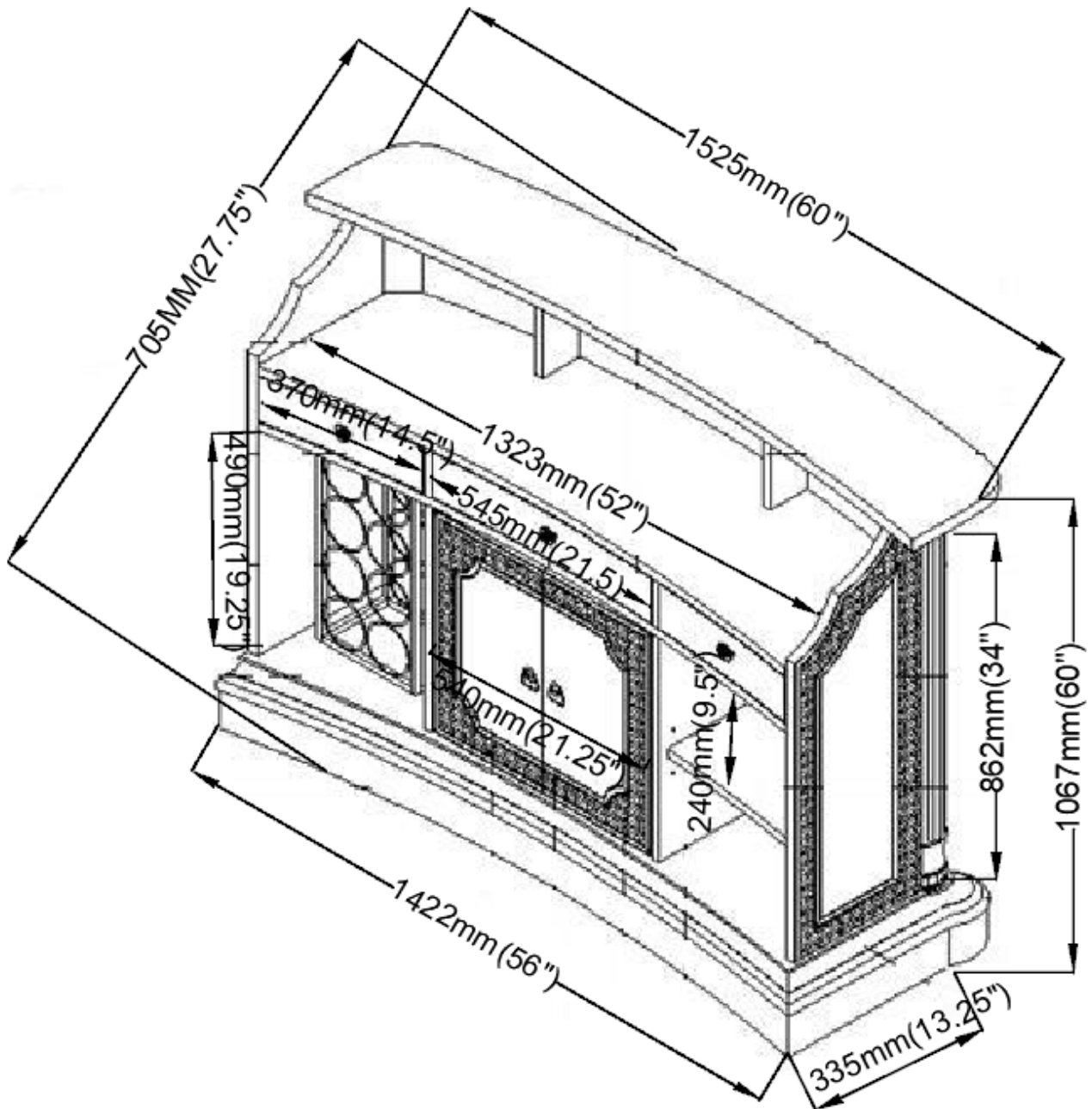

NOTE:

Dimension tolerance $\pm 5\%$