

ASSEMBLY INSTRUCTIONS
COASTER FINE FURNITURE



Fine Furniture for every stage of life

300080
VANITY SET

ASSEMBLY INSTRUCTIONS

ASSEMBLY TIPS:

1. Remove hardware from box and sort by size.
2. Please check to see that all hardware and parts are present prior to start of assembly.
3. Please follow attached instructions in the same sequence as numbered to assure fast & easy assembly.



WARNING!

1. Don't attempt to repair or modify parts that are broken or defective. Please contact the store immediately.
2. This product is for home use only and not intended for commercial establishments.

ASSEMBLY TIME

15 MINUTES

PARTS IDENTIFICATION

A TOP

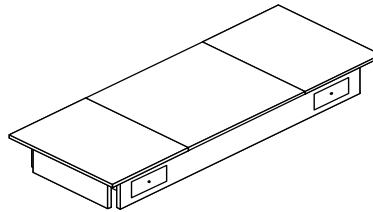

1 PC

B VANITY LEG

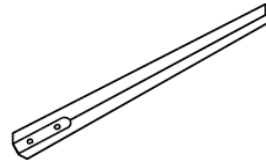

4 PCS

C SEAT CUSHION

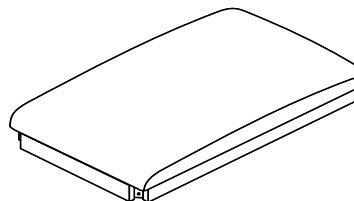

1 PC

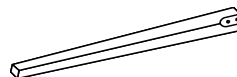

D STOOL LEG



4 PCS

ASSEMBLY INSTRUCTIONS

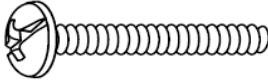
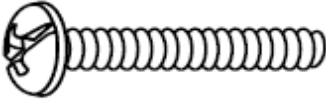
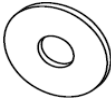
HARDWARE IDENTIFICATION

1	KNOB (Ø31 x 20mm SR)		2 PCS
2	BOLT-SHORT (5/32" x 7/8" SR)		2 PCS
3	BOLT-LONG (1/4" x 1-3/4" RBW)		16 PCS
4	WASHER (1/4" x 11mm RBW)		16 PCS
5	SPRING WASHER (1/4" x 11mm RBW)		8 PCS

ITEM: **300080**

ASSEMBLY INSTRUCTIONS
STEP 1

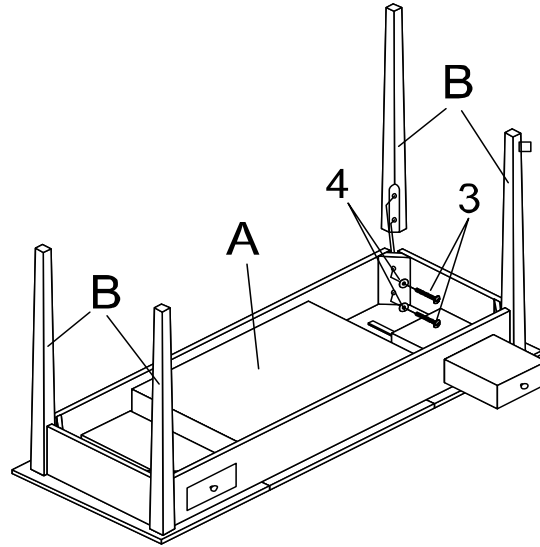

STEP 2

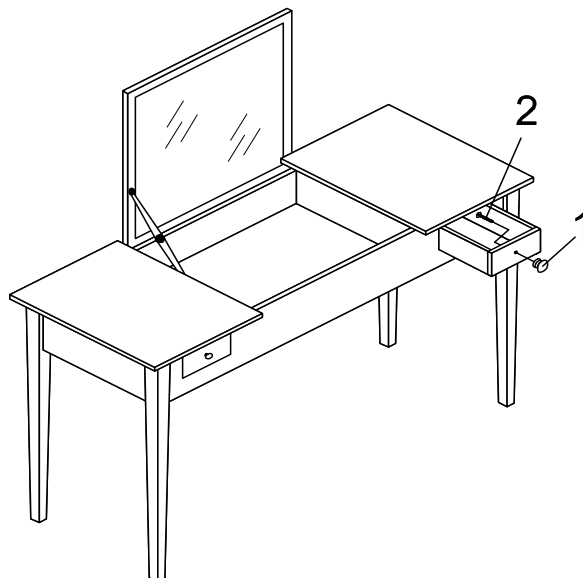

ITEM: **300080**

ASSEMBLY INSTRUCTIONS
STEP 3

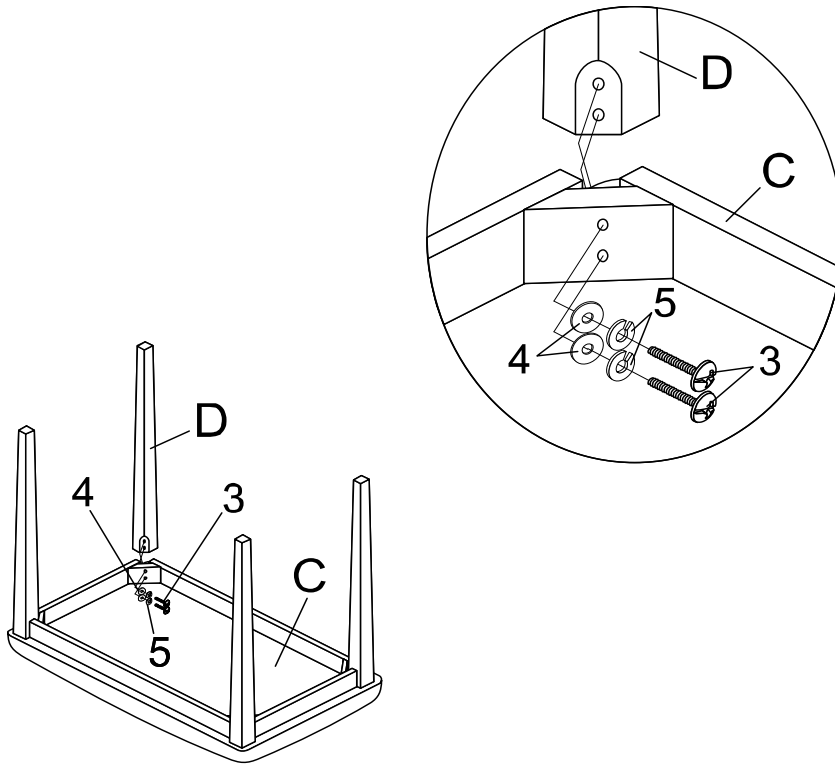

STEP 4

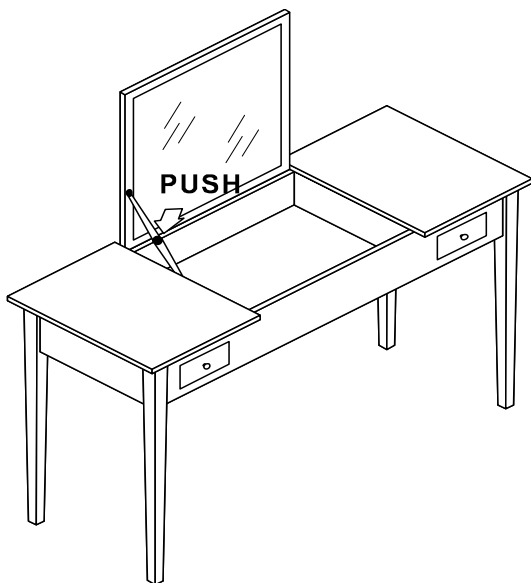

STEP 5

COMPLETE

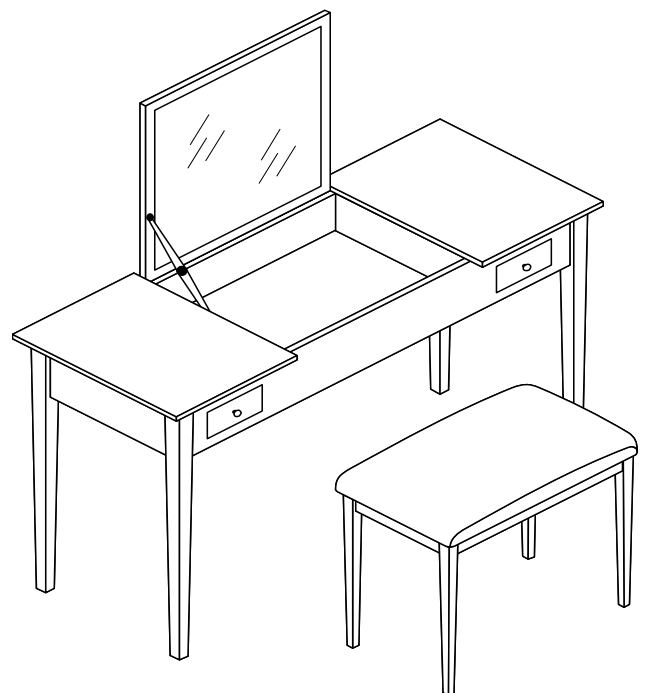

ITEM: **300080**

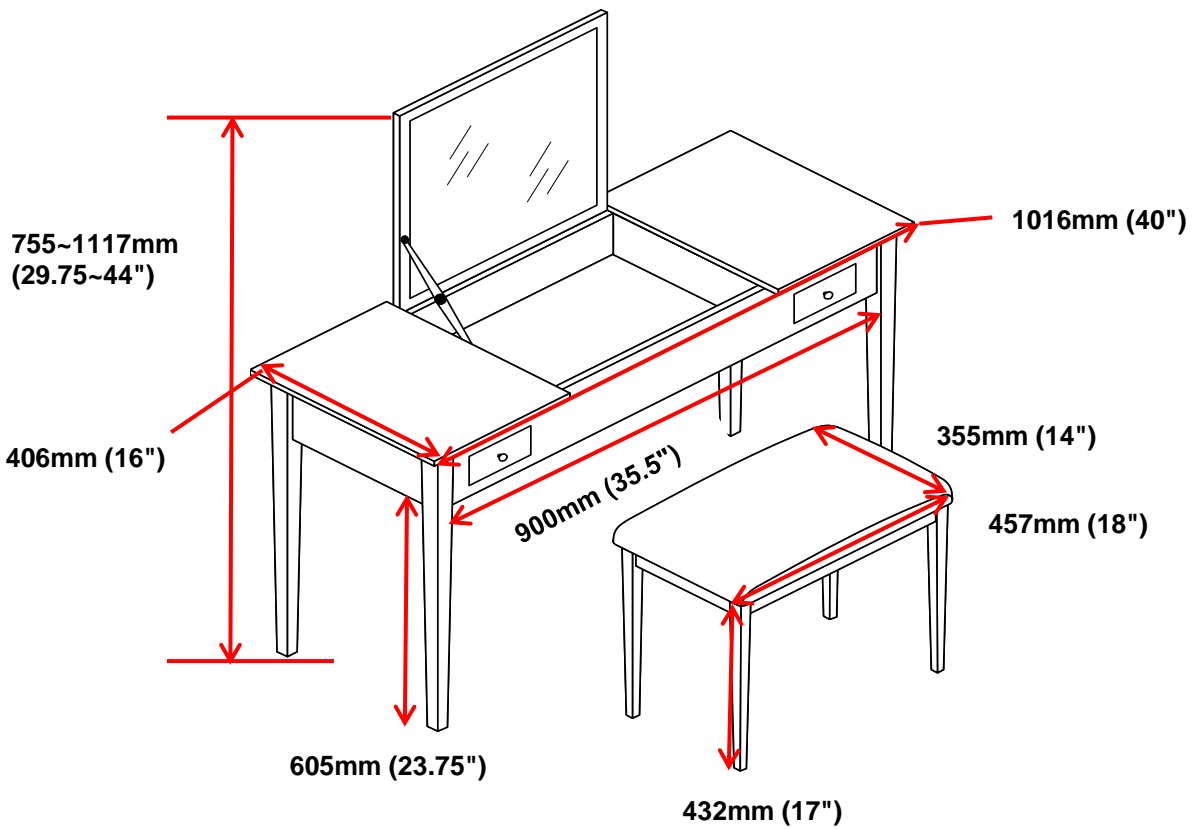
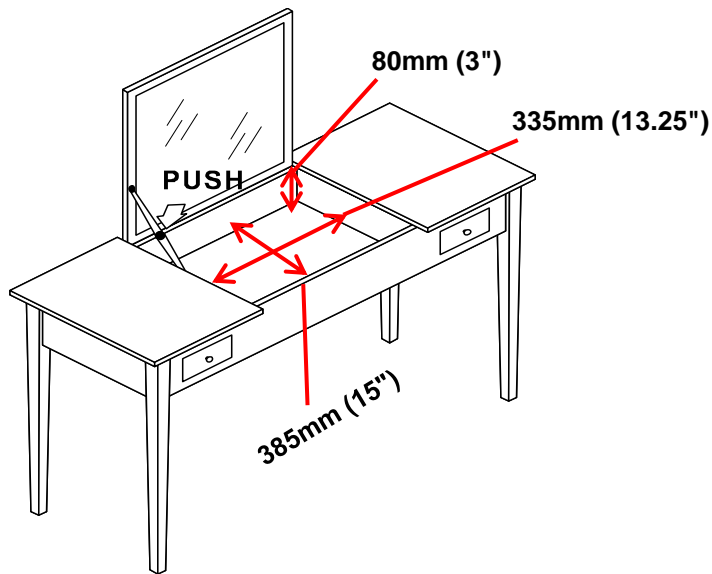

Note : Dimension tolerance $\pm 5\%$