



ASSEMBLY INSTRUCTIONS
COASTER FINE FURNITURE



Fine Furniture for every stage of life

106596

Dining Side Chair

REVISION 0: 05/08/2019
REVISION 1: 02/14/2020

PAGE 1 OF 7

COASTERFURNITURE.COM

ITEM: **106596**



ASSEMBLY INSTRUCTIONS

ASSEMBLY TIPS :

1. Remove hardware from box and sort by size.
2. Please check to see that all hardware and parts are present prior to start of assembly.
3. Please follow attached instructions in the same sequence as numbered to assure fast & easy assembly.



WARNING !



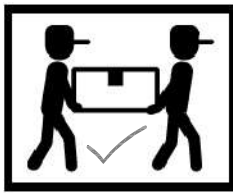

1. Don't attempt to repair or modify parts that are broken or defective. Please contact the store immediately.
2. This product is for home use only and not intended for commercial establishments.

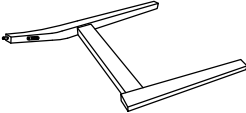
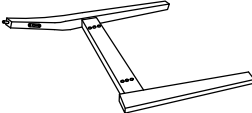

ASSEMBLY TIME

15 MINUTES

PARTS IDENTIFICATION

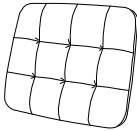
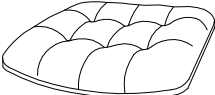
A	RIGHT LEG FRAME		1PC
B	LEFT LEG FRAME		1PC
C	FRONT RAIL (LONG)		1PC
D	BACK RAIL (SHORT)		1PC
E	BACKREST		1PC
F	BACK CUSHION (SMALL)		1PC
G	SEAT CUSHION (BIG)		1PC

ITEM : **106596**



ASSEMBLY INSTRUCTIONS

ASSEMBLY TIPS :





1. Remove hardware from box and sort by size.
2. Please check to see that all hardware and parts are present prior to start of assembly.
3. Please follow attached instructions in the same sequence as numbered to assure fast & easy assembly.

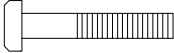

WARNING !

1. Don't attempt to repair or modify parts that are broken or defective. Please contact the store immediately.
2. This product is for home use only and not intended for commercial establishments.

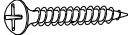
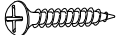
HARDWARE IDENTIFICATION

1	ALLEN WRENCH (M4 x 110MM - BLK)		1PC
2	BOLT (M6 x 40MM - RBW)		4PCS
3	LOCK WASHER (1/4" - BLK)		4PCS
4	LONG PAN HEAD SCREW (#8 x 1 1/4" -BLK)		4PCS
5	SHORT PAN HEAD SCREW (#8 x 1" -BLK)		4PCS
6	CAM BOLT (263.20.847) - ZB)		2PCS
7	WOOD DOWEL (M8 x 30MM)		1PC

NOTE :

Phillips head screw driver is required in the assembly process ; However, manufacturer not provide this item.

ITEM: **106596**

ASSEMBLY INSTRUCTIONS



STEP 1

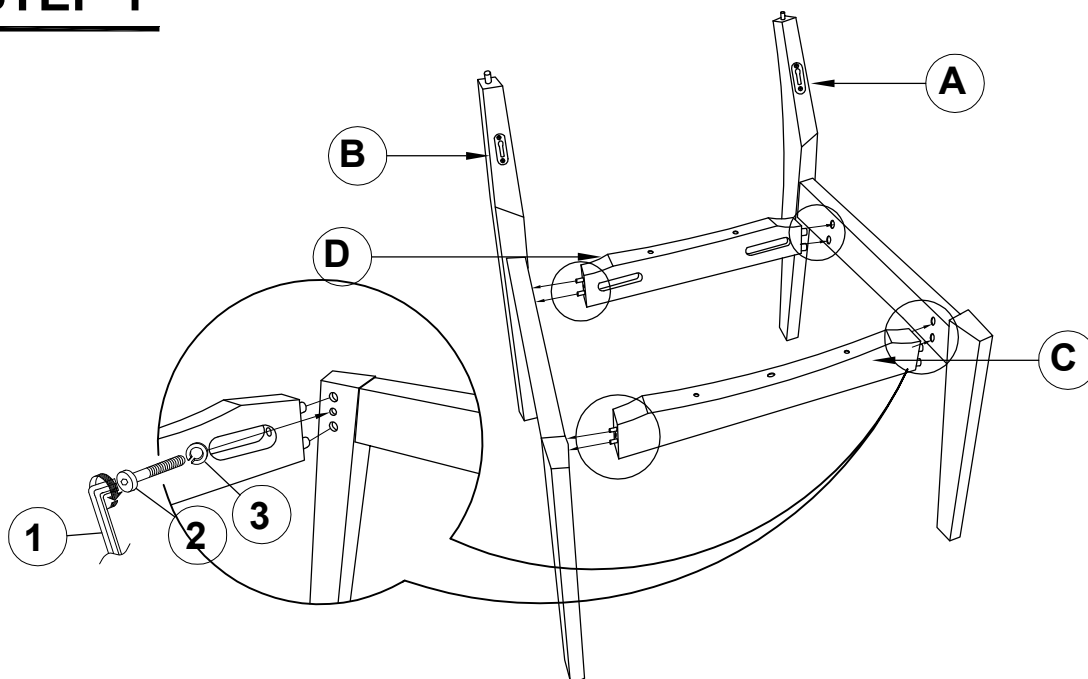

STEP 2

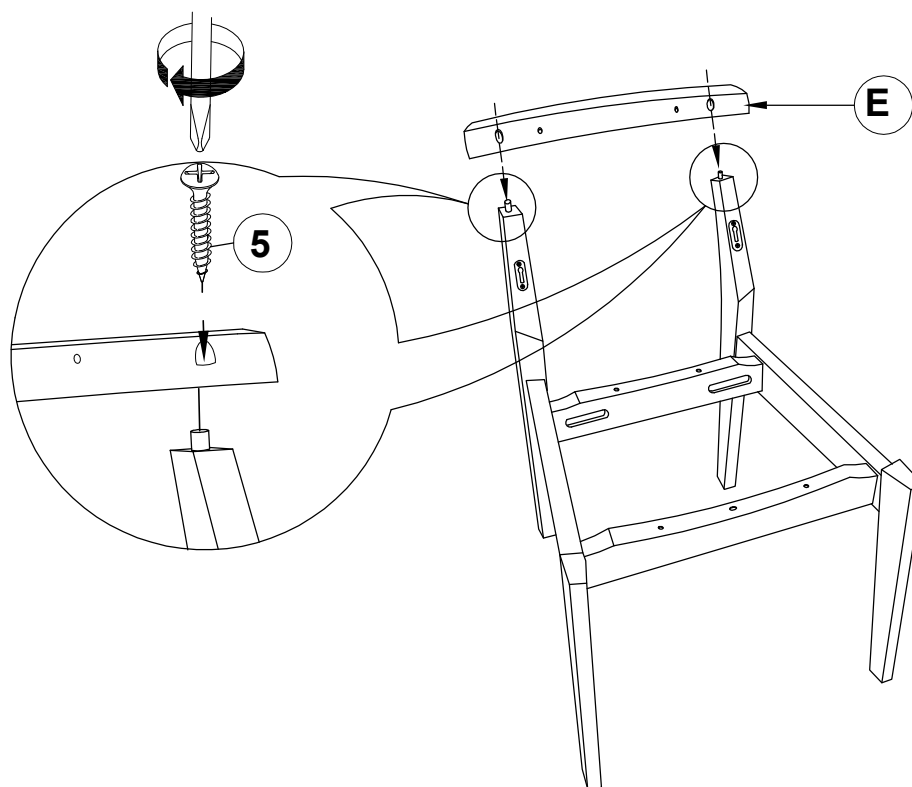

ITEM: **106596**
ASSEMBLY INSTRUCTIONS



STEP 3

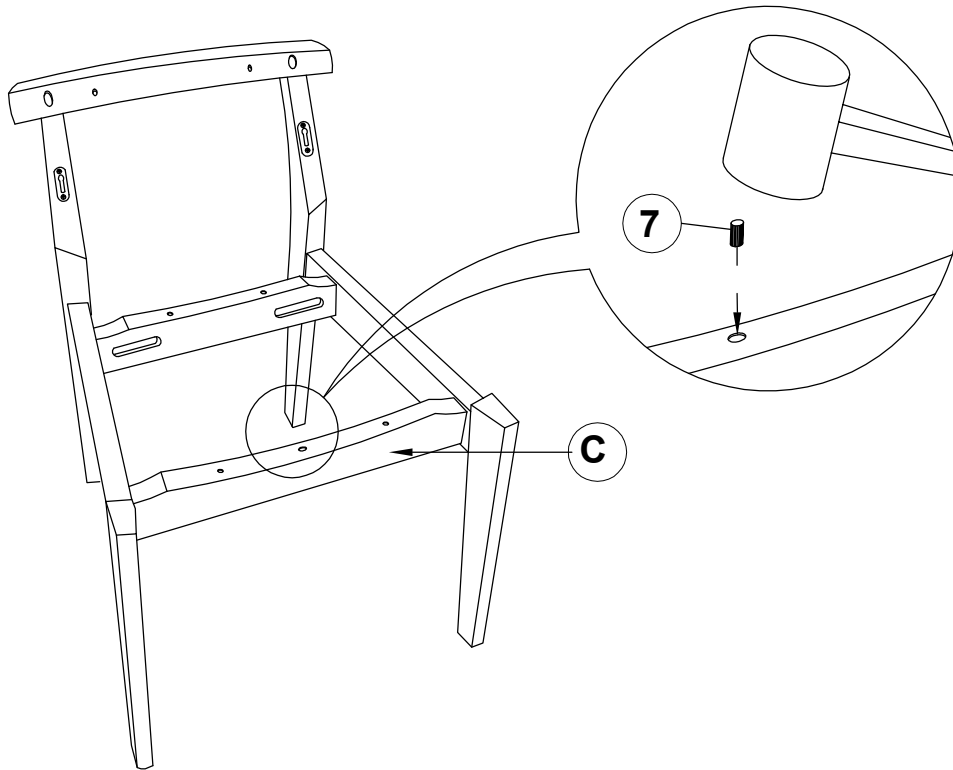

STEP 4

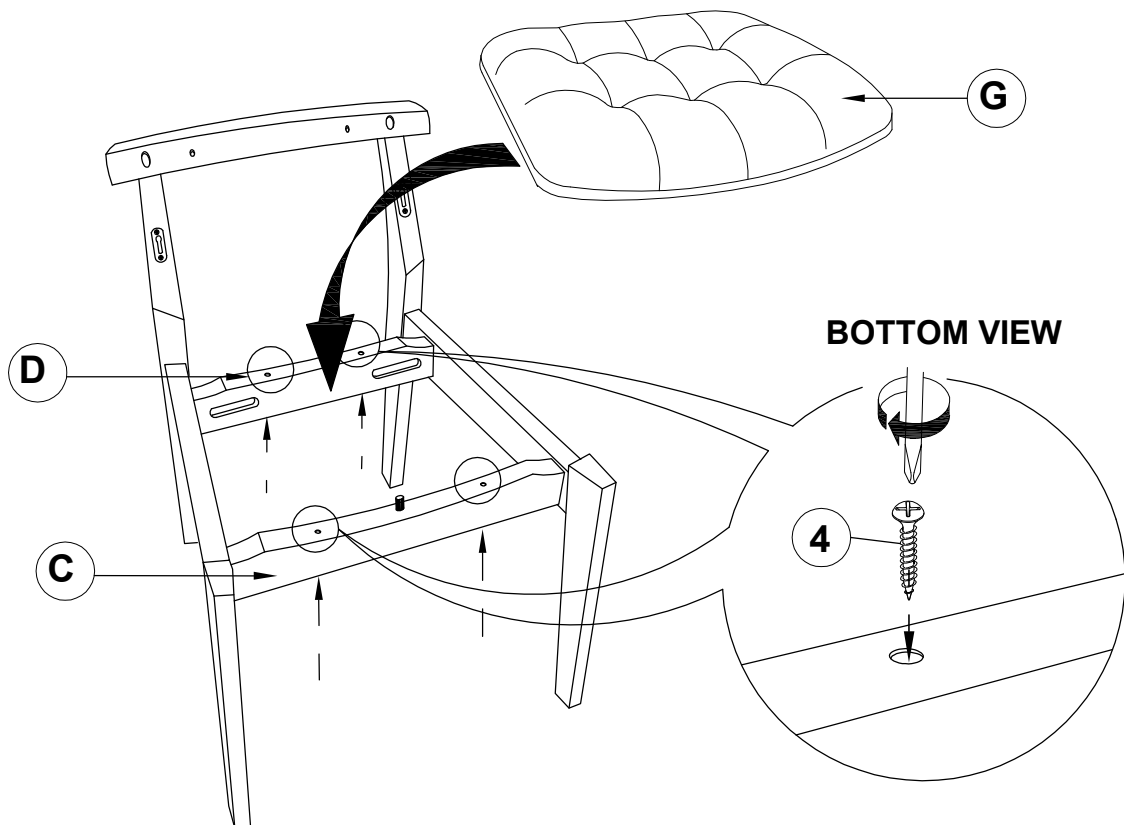

ITEM: **106596**

ASSEMBLY INSTRUCTIONS



STEP 5

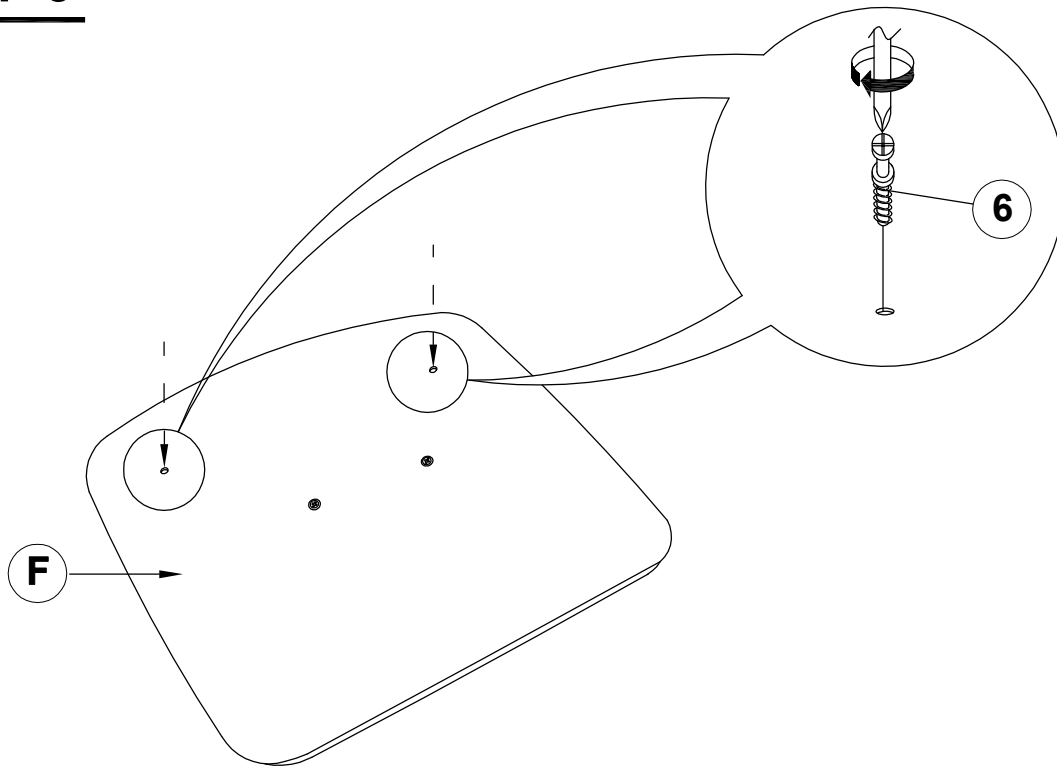

STEP 6

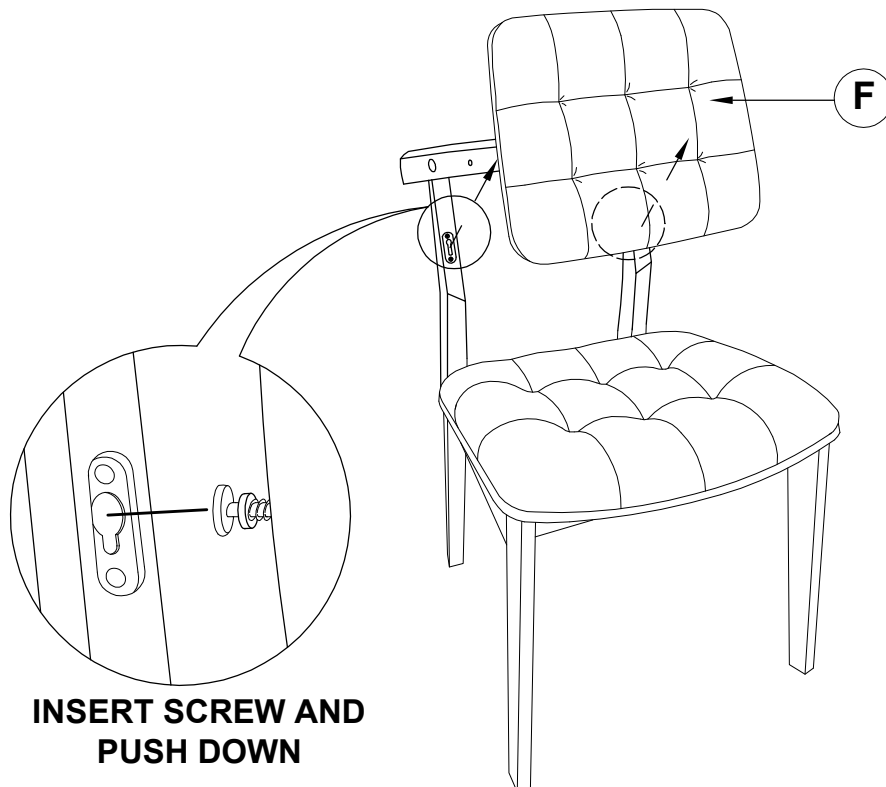

**INSERT SCREW AND
PUSH DOWN**

ITEM: **106596**

ASSEMBLY INSTRUCTIONS



STEP 7

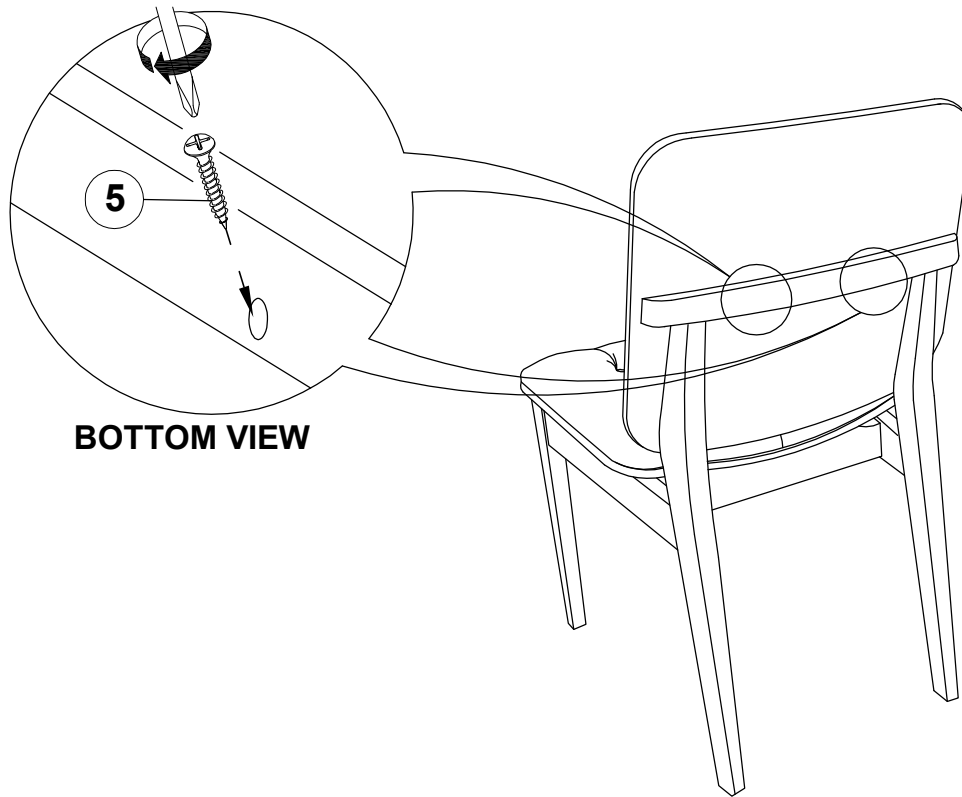

BOTTOM VIEW

STEP 8
COMPLETE

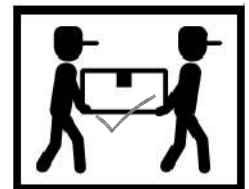
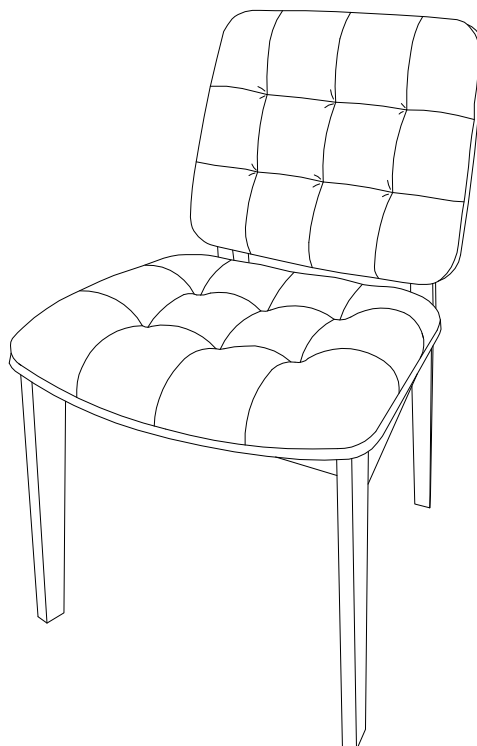

ITEM: **106596**

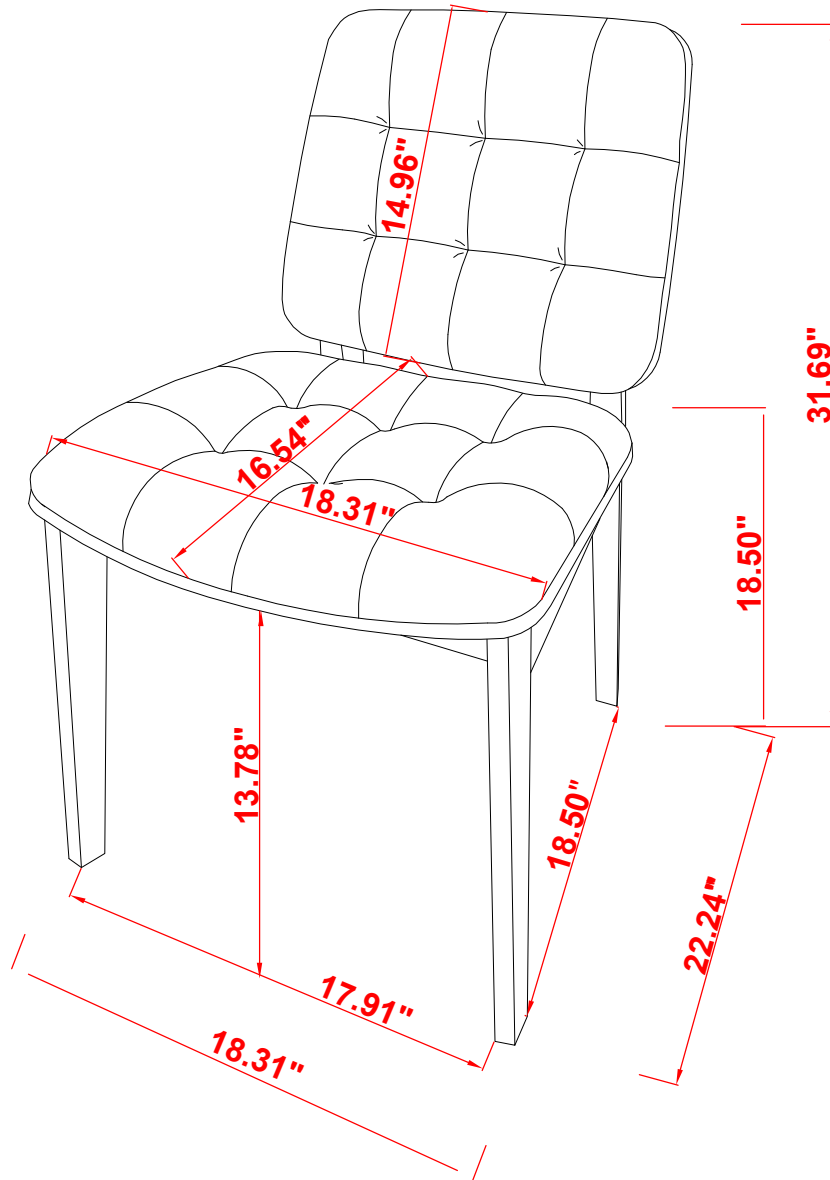

Note : Dimension tolerance $\pm 5\%$