



ASSEMBLY INSTRUCTIONS COASTER FINE FURNITURE



Fine Furniture for every stage of life

300501Q (B1-B2) *Queen Bed*

REVISION 0 : 09/02/2015
REVISION 1 : 09/20/2018
REVISION 2 : 05/20/2019

ITEM : 300501Q (B1-B2)



ASSEMBLY INSTRUCTIONS

ASSEMBLY TIPS :

1. Remove hardware from box and sort by size.
2. Please check to see that all hardware and parts are present prior to start of assembly.
3. Please follow attached instructions in the same sequence as numbered to assure fast & easy assembly.



WARNING!

1. Don't attempt to repair or modify parts that are broken or defective. Please contact the store immediately.
2. This product is for home use only and not intended for commercial establishments.

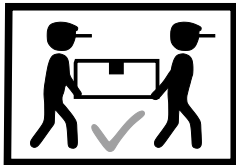

ASSEMBLY TIME

15 MINUTES

PARTS IDENTIFICATION

B1 (BOX 1)

A HEADBOARD

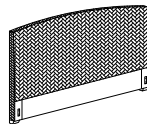

1PC

B2 (BOX 2)

B FOOTBOARD



1PC

C BED RAIL



2PCS

D BED SLAT



4PCS

E BED SLAT SUPPORT WITH LEVELER



4PCS

A 300501Q (B1) FROM BOX 1 HEADBOARD

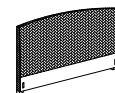

1PC

HARDWARE IDENTIFICATION

Z-B2 (BOX 2) - HARDWARE PACK IS LOCATED IN 300501Q (B2)

1 LONG BOLT
(Ø5/16" x 2" - BLK)

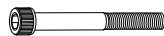

4PCS

2 SHORT BOLT
(Ø5/16" x 1-1/8" - BLK)



4PCS

3 LOCK WASHER
(Ø5/16" - RBW)



8PCS

4 FLAT WASHER
(Ø5/16" - RBW)



8PCS

5 ALLEN WRENCH
(6MM - BLK)

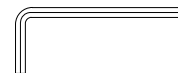

1PC

6 FLAT HEAD SCREW
(Ø5/16" x 1-3/4" - RBW)

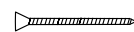

8PCS

NOTE:

Phillips head screw driver is required in the assembly process; however, manufacturer does not provide this item.

ITEM : 300501Q (B1-B2)

ASSEMBLY INSTRUCTIONS

STEP 1

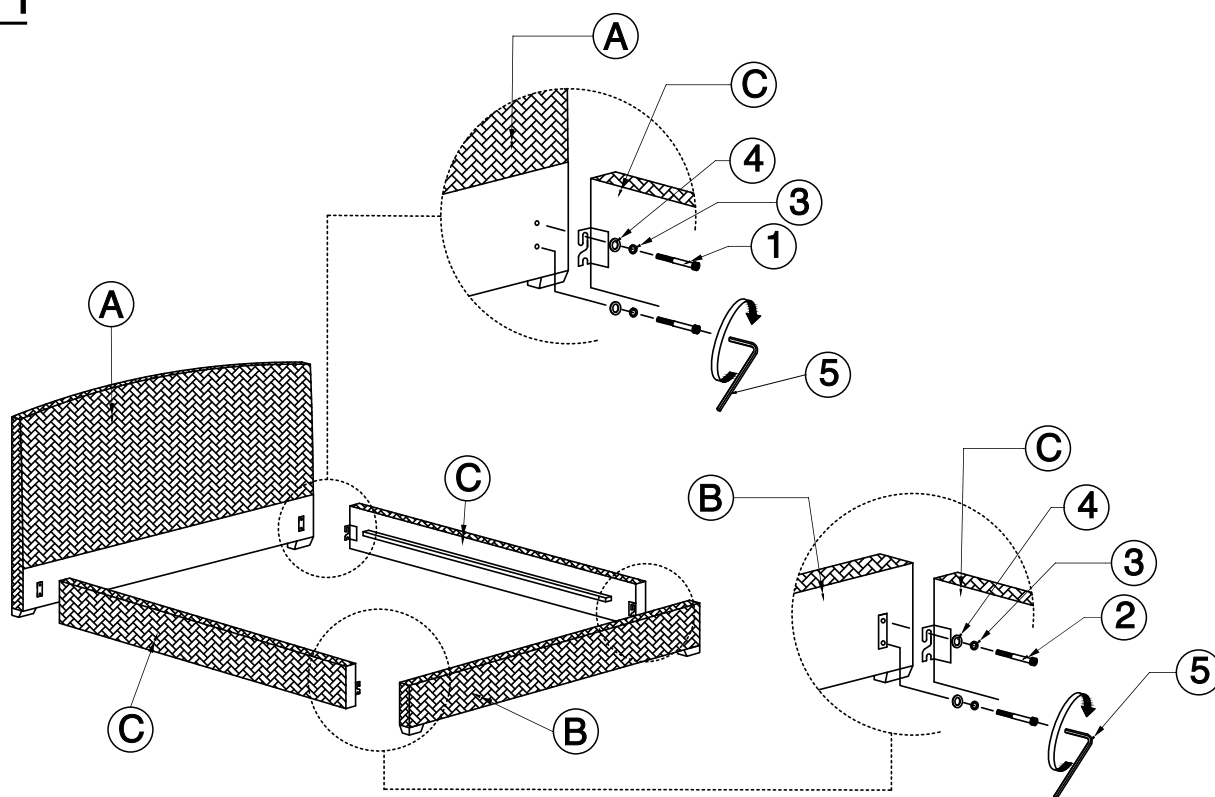

STEP 2

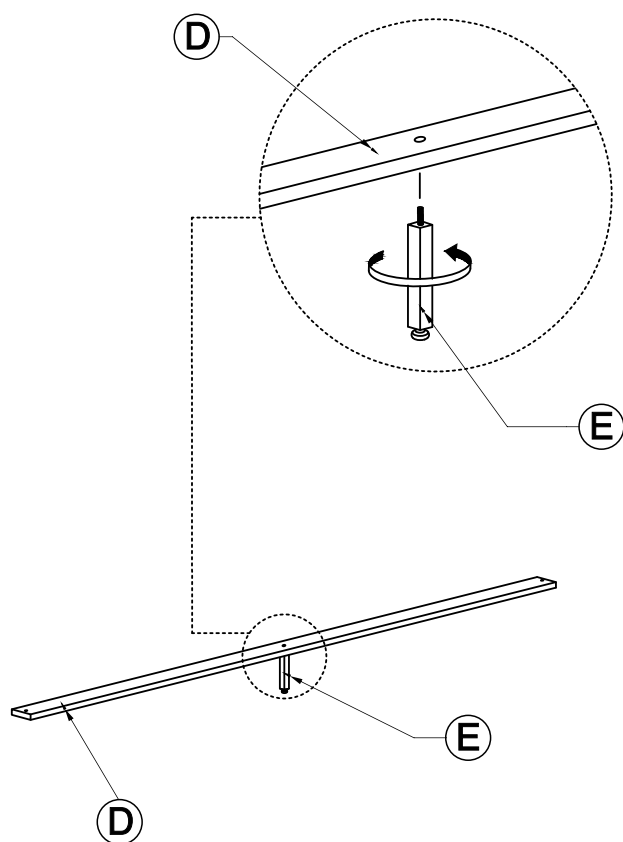

STEP 3 COMPLETE

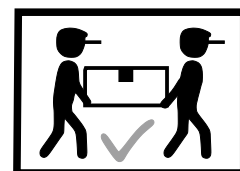
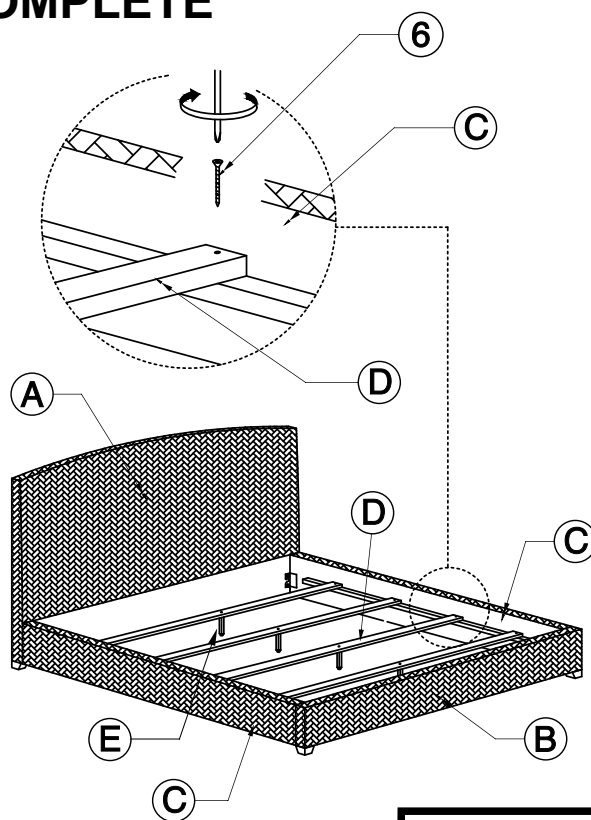

ITEM : 300501Q (B1-B2)

ASSEMBLE HEADBOARD TO METAL FRAME



ASSEMBLY TIPS :

1. Remove hardware from box and sort by size.
2. Please check to see that all hardware and parts are present prior to start of assembly.
3. Please follow attached instructions in the same sequence as numbered to assure fast & easy assembly.



WARNING!

1. Don't attempt to repair or modify parts that are broken or defective. Please contact the store immediately.
2. This product is for home use only and not intended for commercial establishments.

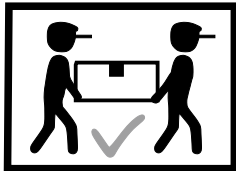

ASSEMBLY TIME

15 MINUTES

PARTS IDENTIFICATION

B1 (BOX 1)

A

HEADBOARD

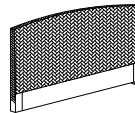

1PC

HARDWARE IDENTIFICATION

Z - B1 (BOX 1) - HARDWARE PACK IS LOCATED IN 300501Q (B1)

7	LONG BOLT (Ø7/23" x 2-3/8" - BLK)		6PCS
8	LOCK WASHER (Ø4/16" - RBW)		6PCS
9	FLAT WASHER (Ø4/16" - RBW)		12PCS
10	ALLEN WRENCH (4mm - BLK)		1PC
11	HEX NUT (M 6mm - BLK)		6PCS
12	WRENCH (3-3/8" x 1-1/8" - RBW)		1PC

ITEM : 300501Q (B1-B2)



ASSEMBLE HEADBOARD TO METAL FRAME
COMPLETE

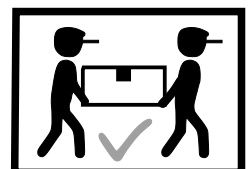
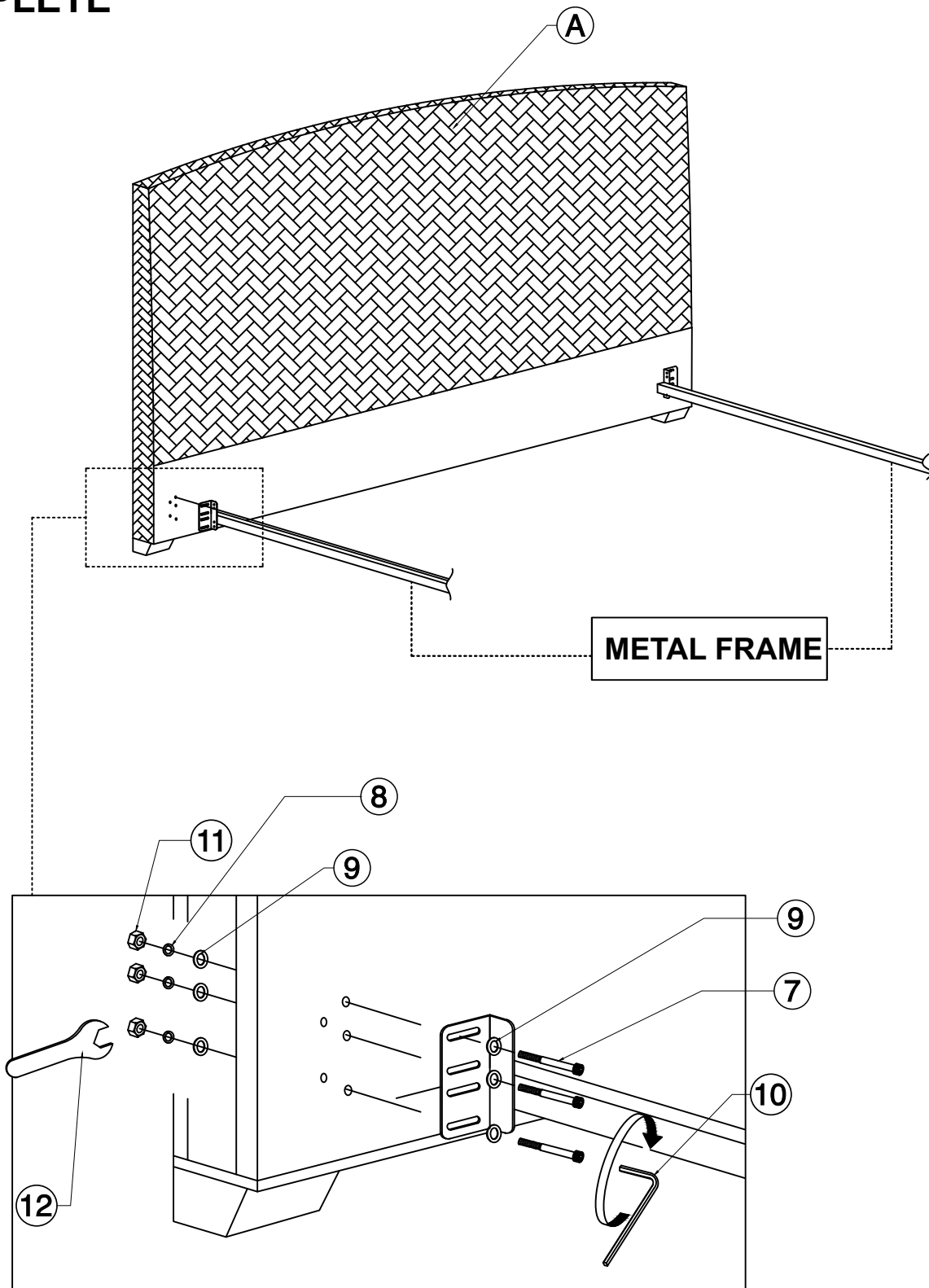

ITEM : 300501Q (B1-B2)



INNER SIZE : 61.25" x 81.25"

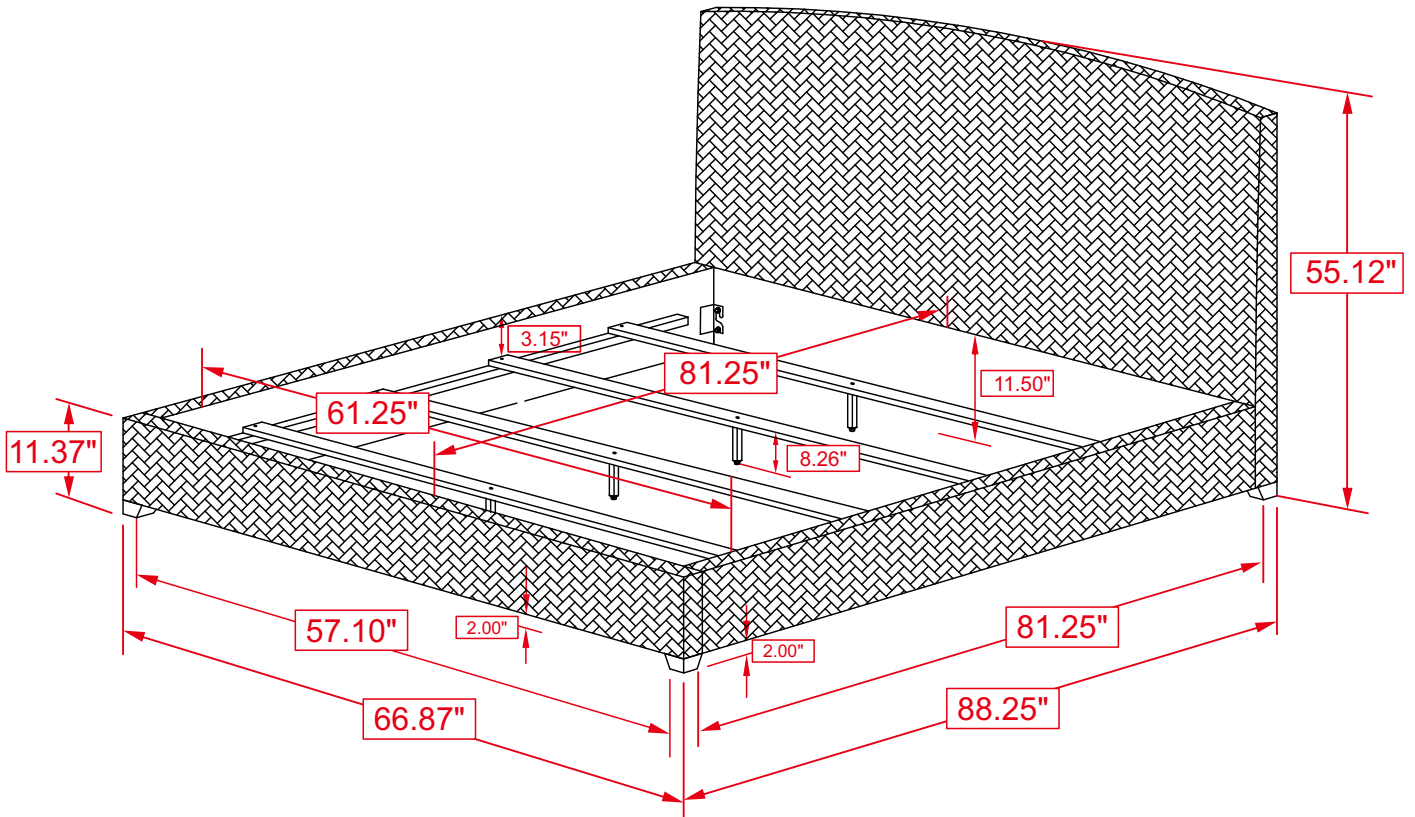

Note : Dimension tolerance $\pm 5\%$