

ASSEMBLY INSTRUCTIONS
COASTER FINE FURNITURE

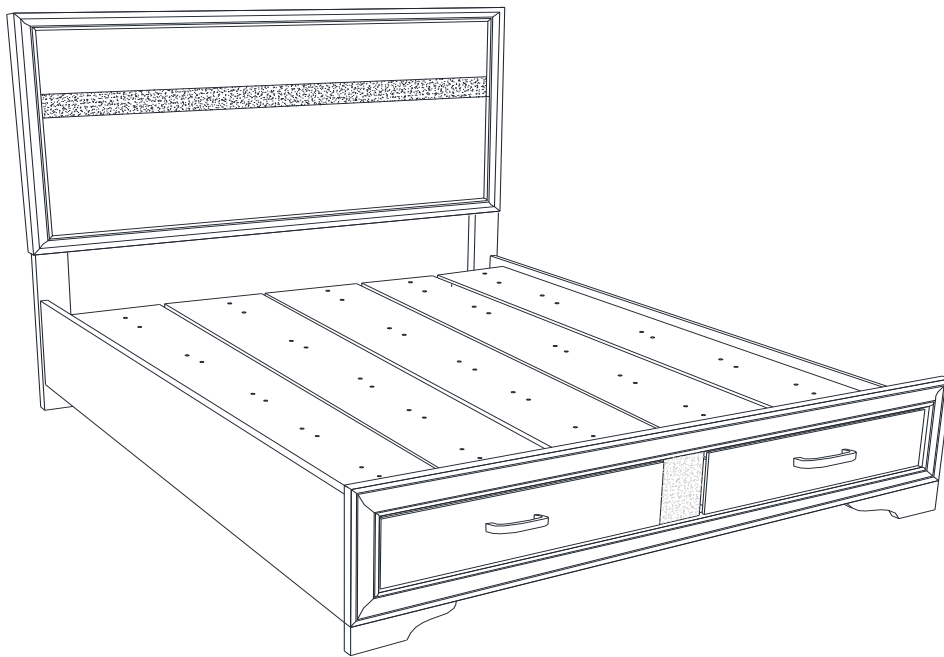

Fine Furniture for every stage of life

206361Q (B1-B3)
Queen Storage Bed

REVISION 0 : 05/23/2017
REVISION 1 : 06/30/2017
REVISION 2 : 09/07/2018
REVISION 3 : 12/06/2018
REVISION 4 : 10/25/2019

ITEM: 206361Q (B1-B3)



ASSEMBLY INSTRUCTIONS

ASSEMBLY TIPS:

1. Remove hardware from box and sort by size.
2. Please check to see that all hardware and parts are present prior to start of assembly.
3. Please follow attached instructions in the same sequence as numbered to assure fast & easy assembly.



WARNING!

1. Don't attempt to repair or modify parts that are broken or defective. Please contact the store immediately.
2. This product is for home use only and not intended for commercial establishments.



ASSEMBLY TIME



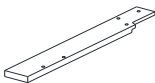
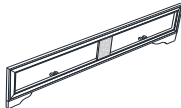
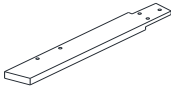

20 MINUTES

PARTS IDENTIFICATION

B1 (BOX 1)

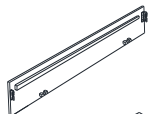
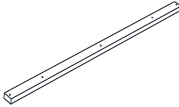
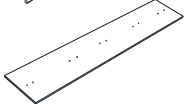
A	HEADBOARD PANEL		1PC	C	RIGHT HEADBOARD LEG		1PC
B	FOOTBOARD		1PC	D	LEFT HEADBOARD LEG		1PC

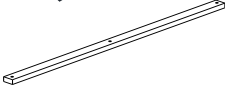
B2 (BOX 2)

E	BED RAIL		2PCS	I	DRAWER BOTTOM TRESTLE BAR		1PC
F	CONCEAL PANEL		5PCS	J	DRAWER SUPPORT RAIL		2PCS
G	BED SLAT		5PCS	K	DRAWER SUPPORT LEG WITH LEVELER		1PC
H	BED SLAT SUPPORT WITH LEVELER		5PCS				

B3 (BOX 3)

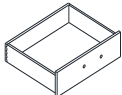
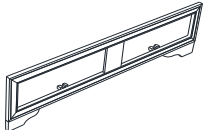
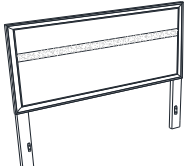
L	DRAWER BOX		2PCS	B	206361Q(B1) FROM BOX 1 FOOTBOARD		1PC
HB	206361Q(B1) FROM BOX 1 HEADBOARD COMPLETE		1PC				

ITEM: 206361Q (B1-B3)



ASSEMBLY INSTRUCTIONS

ASSEMBLY TIPS:

1. Remove hardware from box and sort by size.
2. Please check to see that all hardware and parts are present prior to start of assembly.
3. Please follow attached instructions in the same sequence as numbered to assure fast & easy assembly.







WARNING!









1. Don't attempt to repair or modify parts that are broken or defective. Please contact the store immediately.
2. This product is for home use only and not intended for commercial establishments.

HARDWARE IDENTIFICATION

Z-B1 (BOX 1) - HARDWARE PACK IS LOCATED IN 206361Q (B1)

1	BOLT (M6 x 30mm - BLK)		6PCS	3	FLAT WASHER (1/4"ID x 13mm - BLK)		6PCS
2	LOCK WASHER (1/4" - BLK)		6PCS	4	ALLEN WRENCH (M4 x 60mm - BLK)		1PC

Z-B2 (BOX 2) - HARDWARE PACK IS LOCATED IN 206361Q (B2)

5	FLAT HEAD SCREW (M4 x 32mm - RBW)		14PCS	9	LOCK WASHER (1/4" - BLK)		2PCS
6	PAN HEAD SCREW (M3.5 x 20mm - BLK)		25PCS	10	FLAT WASHER (1/4"ID x 13mm - BLK)		2PCS
7	SHORT BOLT (M6 x 35mm - BLK)		2PCS	11	SMALL ALLEN WRENCH (M4 x 60mm - BLK)		1PC
8	LONG BOLT (M6 x 50mm - BLK)		6PCS	12	BIG ALLEN WRENCH (M5 x 68mm - BLK)		1PC

NOTE:

Phillips head screw driver is required in the assembly process; however, manufacturer does not provide this item.

ASSEMBLY INSTRUCTIONS

STEP 1

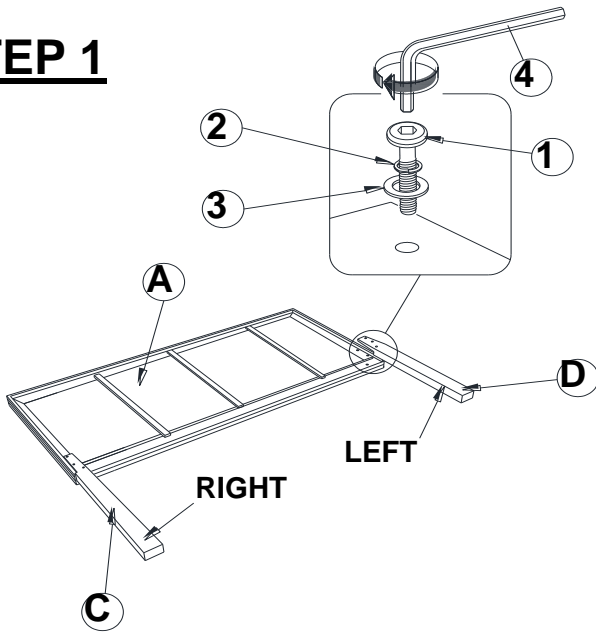

****BACK VIEW****

Note : Please take note of the marking sticker (L&R) on the leg.

STEP 2

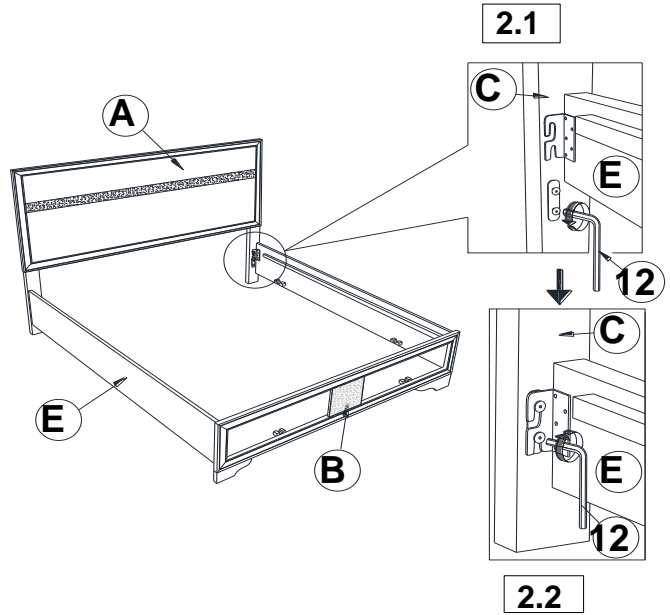

STEP 3

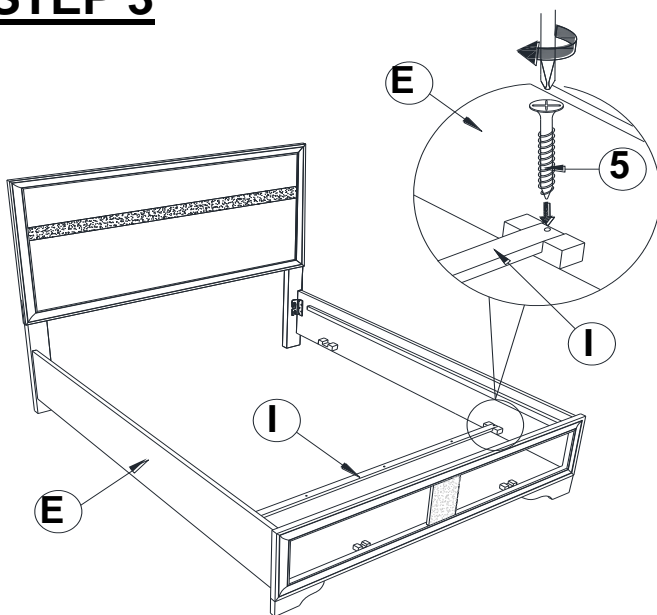

STEP 4

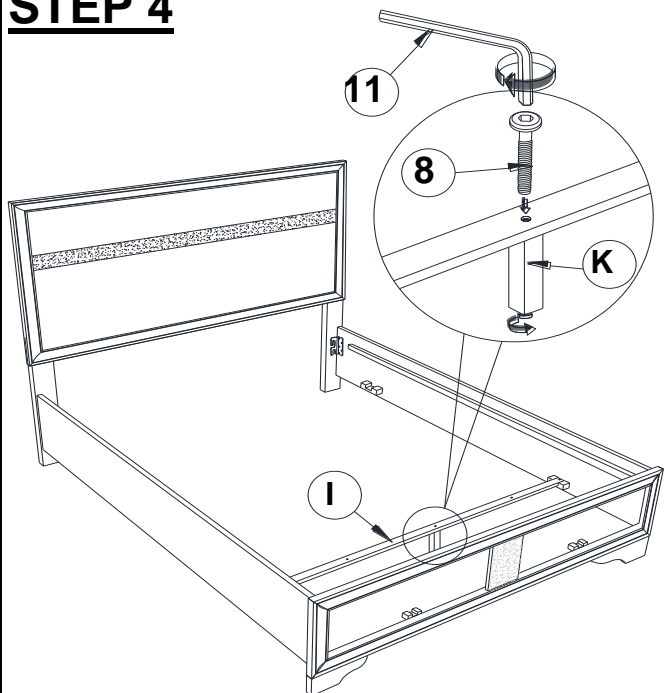

ASSEMBLY INSTRUCTIONS

STEP 5

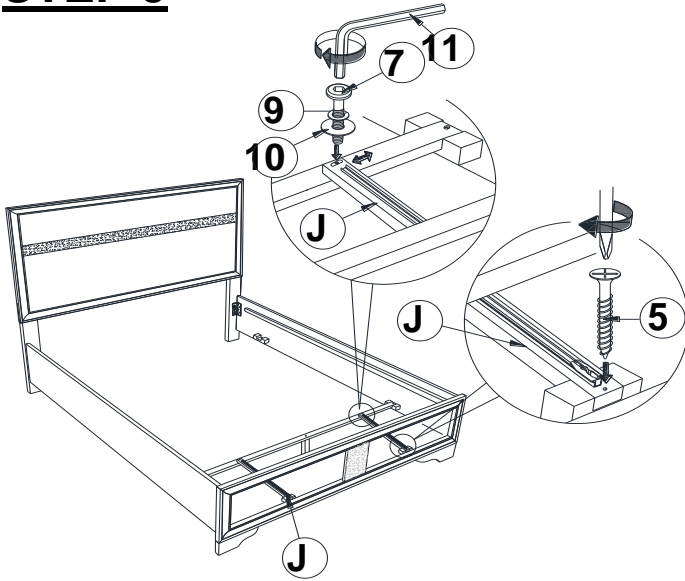

STEP 6

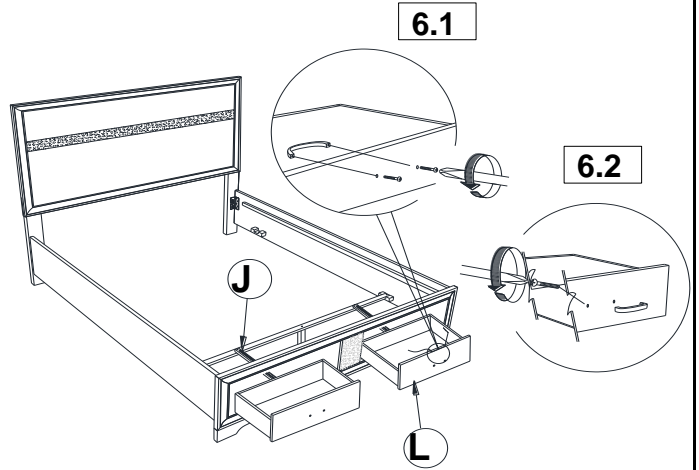

STEP 7

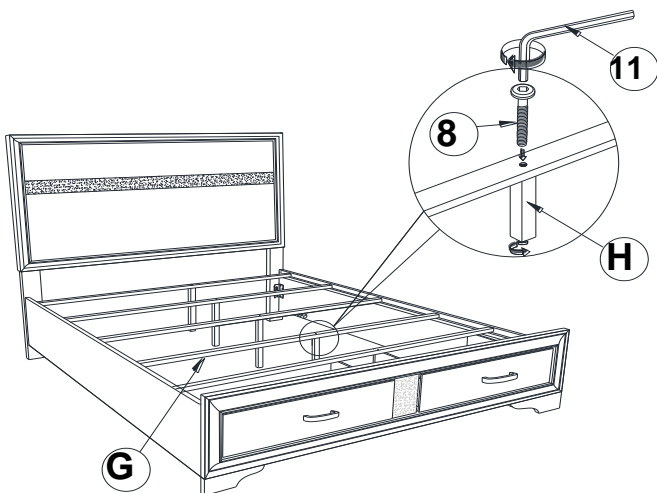

STEP 8

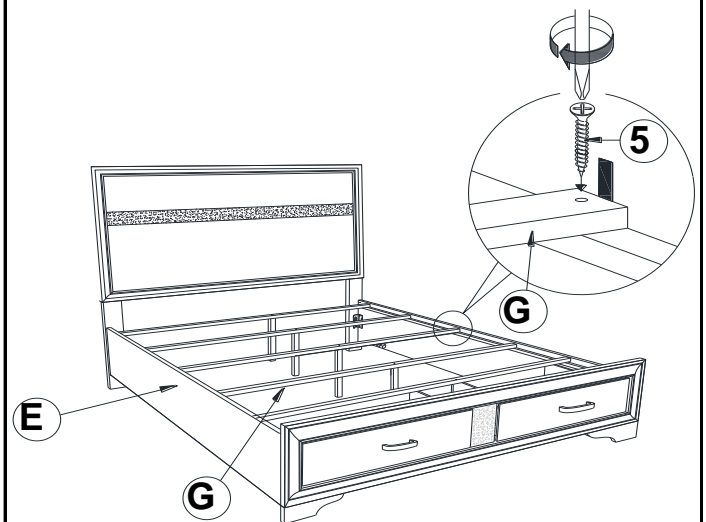

ASSEMBLY INSTRUCTIONS

STEP 9

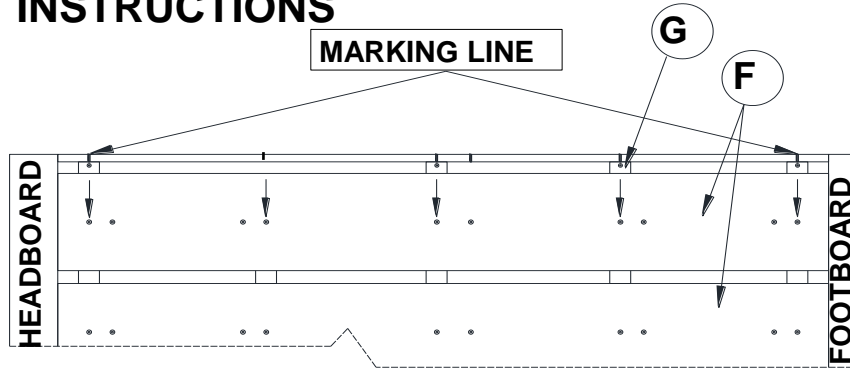

TIGHTEN THE PANHEAD SCREW (6) BY FOLLOW THE ARROW AS SHOWN

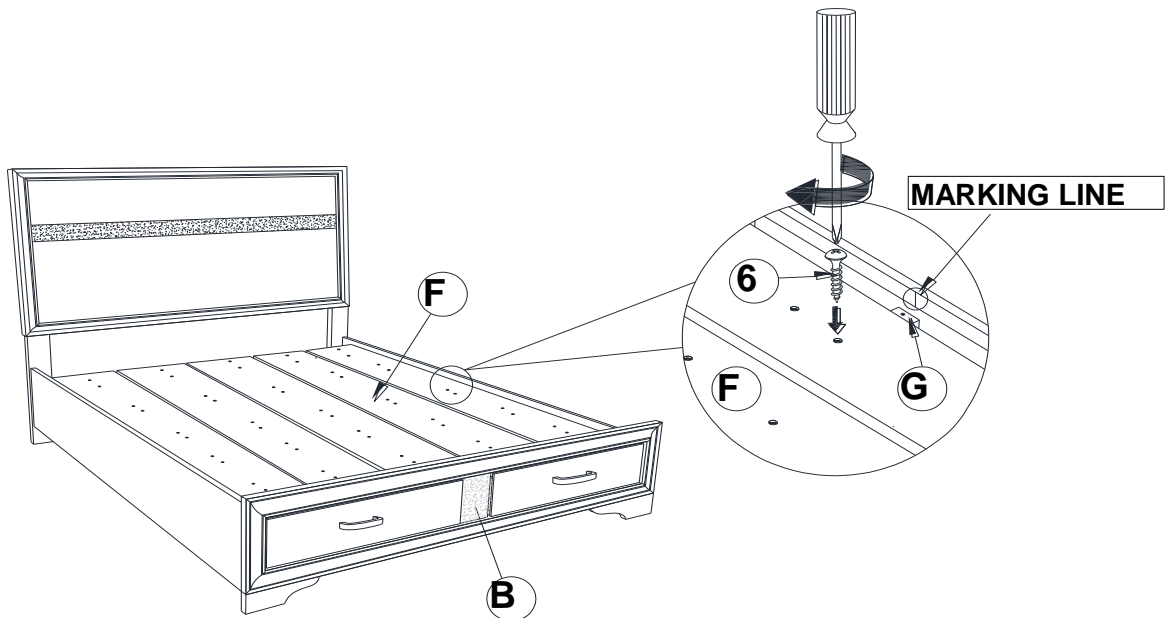

STEP 10
COMPLETE

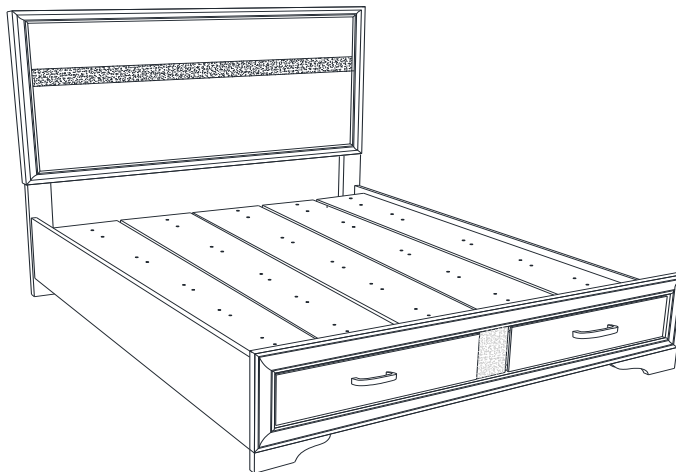

ITEM: 206361Q (B1-B3)



INNER SIZE: 60.8" x 81"

INNER SIZE OF DRAWER : 3.94"x14.96"x23.23"

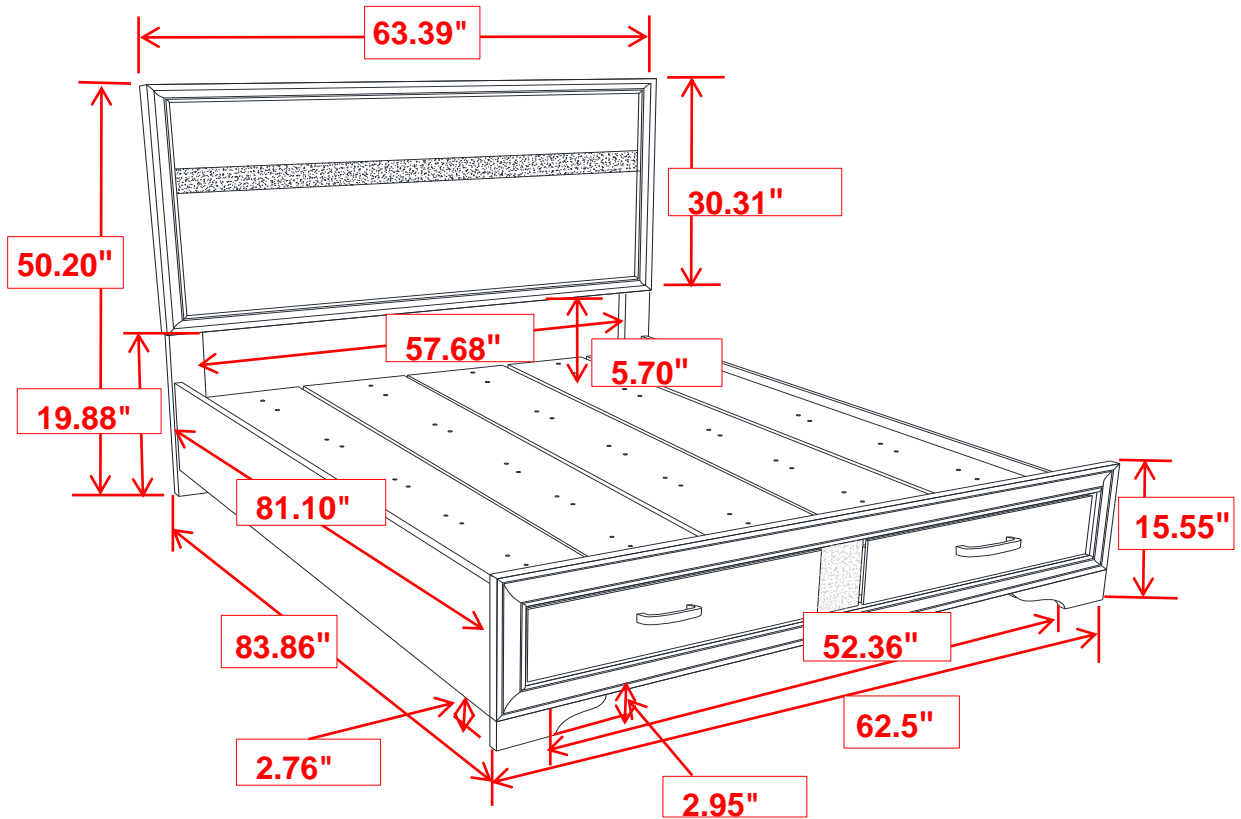

Note : Dimension tolerance $\pm 5\%$