

ASSEMBLY INSTRUCTIONS
COASTER FINE FURNITURE

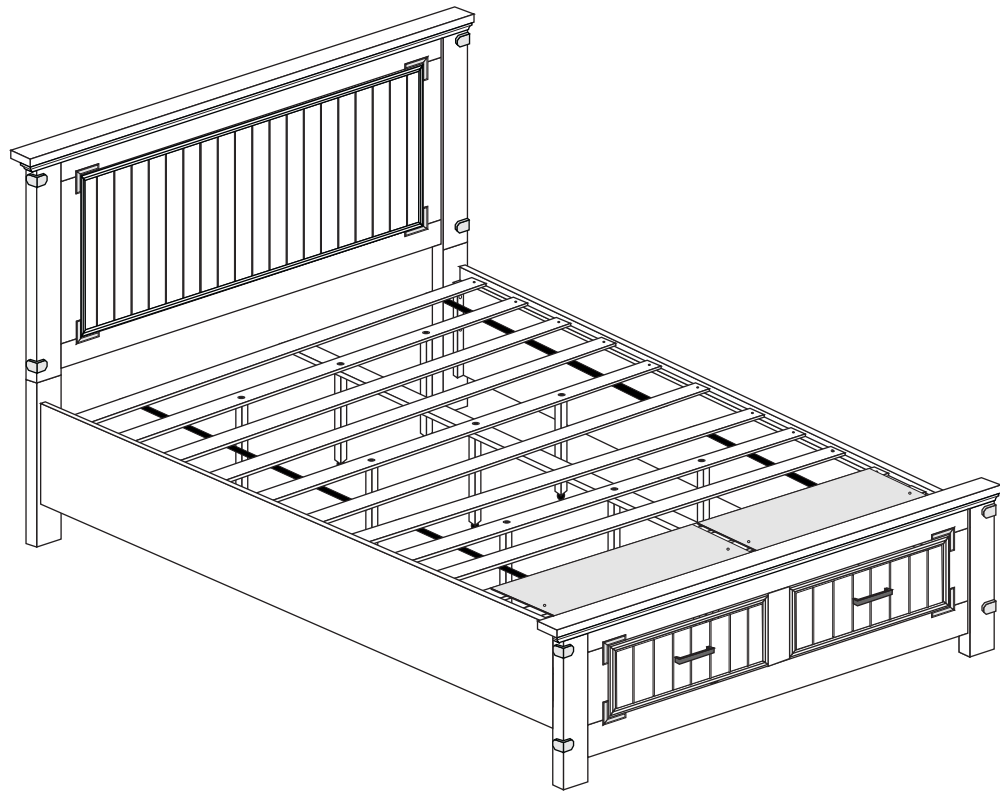

Fine Furniture for every stage of life

205260KW (B1-B3)
California King Storage Bed

REVISION 0:07/27/2016
REVISION 1:11/20/2018
REVISION 2:01/14/2020

COASTERFURNITURE.COM

ITEM: 205260KW (B1 - B3)

ASSEMBLY INSTRUCTIONS



ASSEMBLY TIPS:

1. Remove hardware from box and sort by size.
2. Please check to see that all hardware and parts are present prior to start of assembly.
3. Please follow attached instructions in the same sequence as numbered to assure fast & easy assembly.



WARNING!

1. Don't attempt to repair or modify parts that are broken or defective. Please contact the store immediately.
2. This product is for home use only and not intended for commercial establishments.



ASSEMBLY TIME

40 MINUTES

PARTS IDENTIFICATION

B1 (BOX 1)

A HEADBOARD PANEL



1PC

B RIGHT HEADBOARD LEG



1PC

C LEFT HEADBOARD LEG



1PC

D WOOD CLEAT

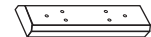

2PCS

B2 (BOX 2)

E STORAGE FOOTBOARD

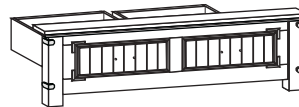

1PC

B3 (BOX 3)

F BED RAIL



2PCS

G HEADBOARD ROLL SLAT (6PCS)

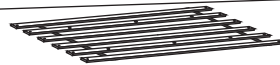

1SET

H FOOTBOARD ROLL SLAT (6PCS)



1SET

I CENTER RAIL



1PC

J CENTER RAIL SUPPORT WITH LEVELER (WITHOUT HOLE)



3PCS

K CENTER RAIL SUPPORT WITH LEVELER (WITH HOLE)



1PC

L BED SLAT SUPPORT WITH LEVELER (WITHOUT HOLE)



6PCS

M BED SLAT SUPPORT WITH LEVELER (WITH HOLE)



2PCS

N CONCEAL PANEL



2PCS

HB 205260KW (B1) FROM BOX 1 HEADBOARD COMPLETE



1PC

E 205260KW (B2) FROM BOX 2 STORAGE FOOTBOARD



1PC

ITEM: 205260KW (B1 - B3)

ASSEMBLY INSTRUCTIONS



ASSEMBLY TIPS:

1. Remove hardware from box and sort by size.
2. Please check to see that all hardware and parts are present prior to start of assembly.
3. Please follow attached instructions in the same sequence as numbered to assure fast & easy assembly.











WARNING!

1. Don't attempt to repair or modify parts that are broken or defective. Please contact the store immediately.
2. This product is for home use only and not intended for commercial establishments.

HARDWARE IDENTIFICATION

Z-B3 (BOX 3) - HARDWARE PACK IS LOCATED IN 205260KW (B3)

1	LONG BOLT (M6 x 60mm - RBW)		16PCS
2	SHORT BOLT (M6 x 40mm - RBW)		20PCS
3	BIG FLAT WASHER (M6 x 19mm - RBW)		12PCS
4	SMALL FLAT WASHER (M6 x 13mm - RBW)		12PCS
5	LOCK WASHER (M6 x 13mm - RBW)		24PCS
6	LONG FLAT HEAD SCREW (M4 x 30mm - RBW)		27PCS
7	SHORT FLAT HEAD SCREW (M4 x 16mm - RBW)		8PCS
8	ALLEN WRENCH (M4 x 58mm - BLK)		1PC
9	WOOD DOWEL (Ø 10 x 30mm)		8PCS

NOTE :

Phillips head screw driver is required in the assembly process; however, manufacturer does not provide this item.

ITEM: 205260KW (B1 - B3)

ASSEMBLY INSTRUCTIONS



STEP 1

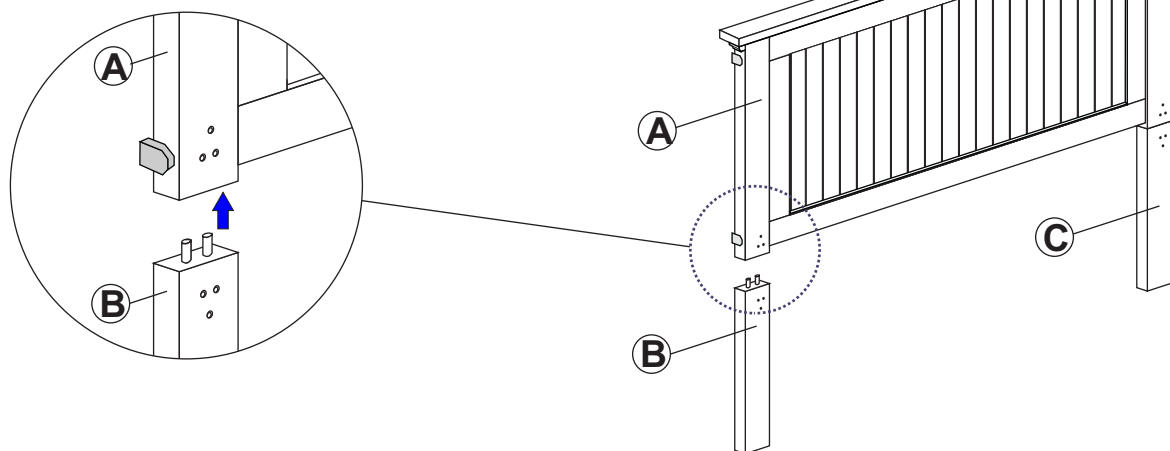

STEP 2

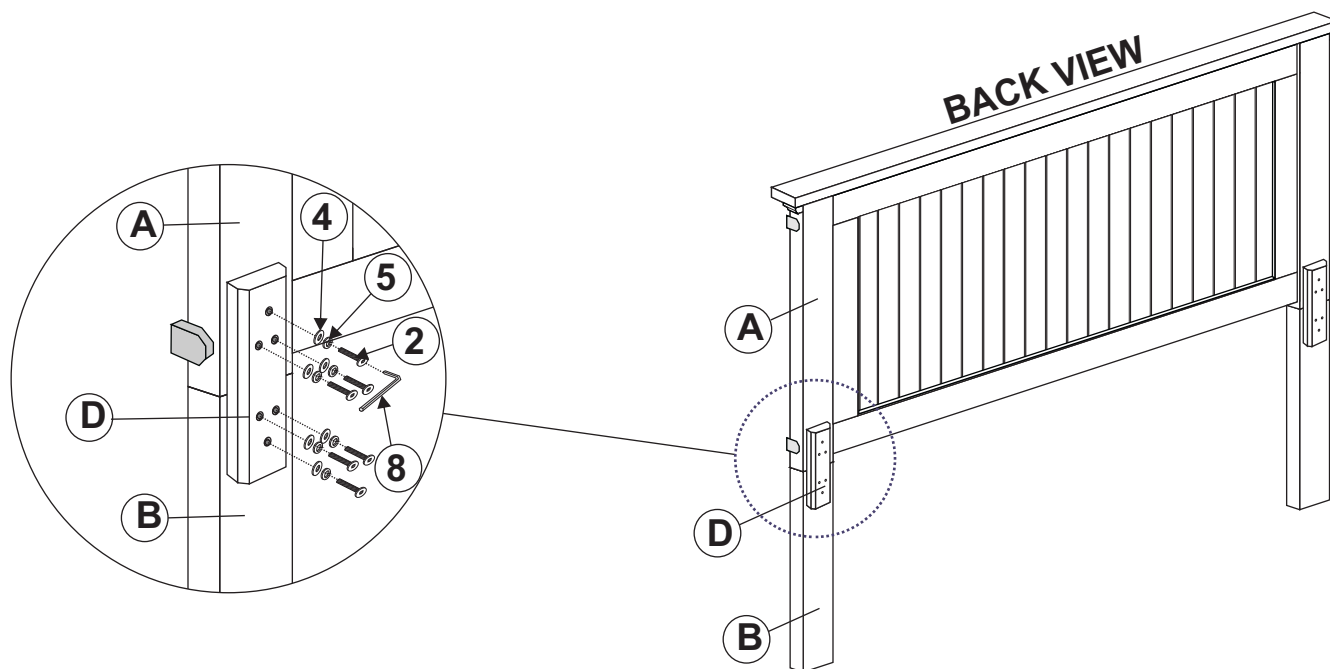

ITEM: 205260KW (B1 - B3)

ASSEMBLY INSTRUCTIONS



STEP 3

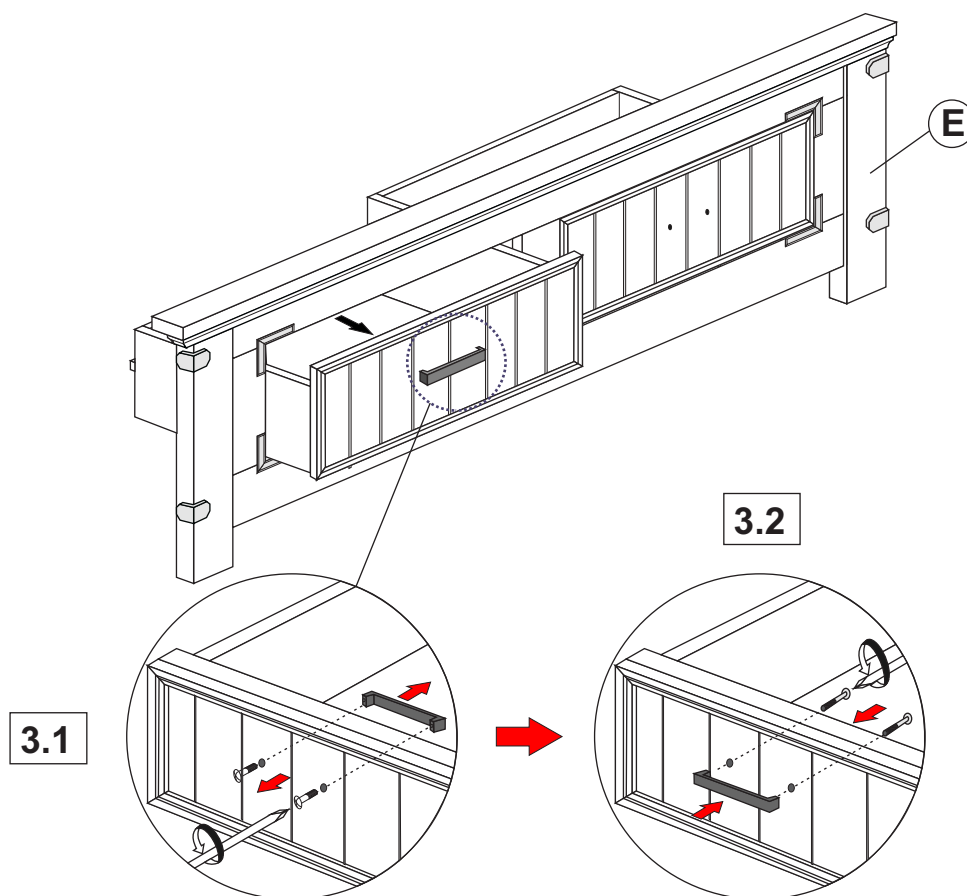

STEP 4

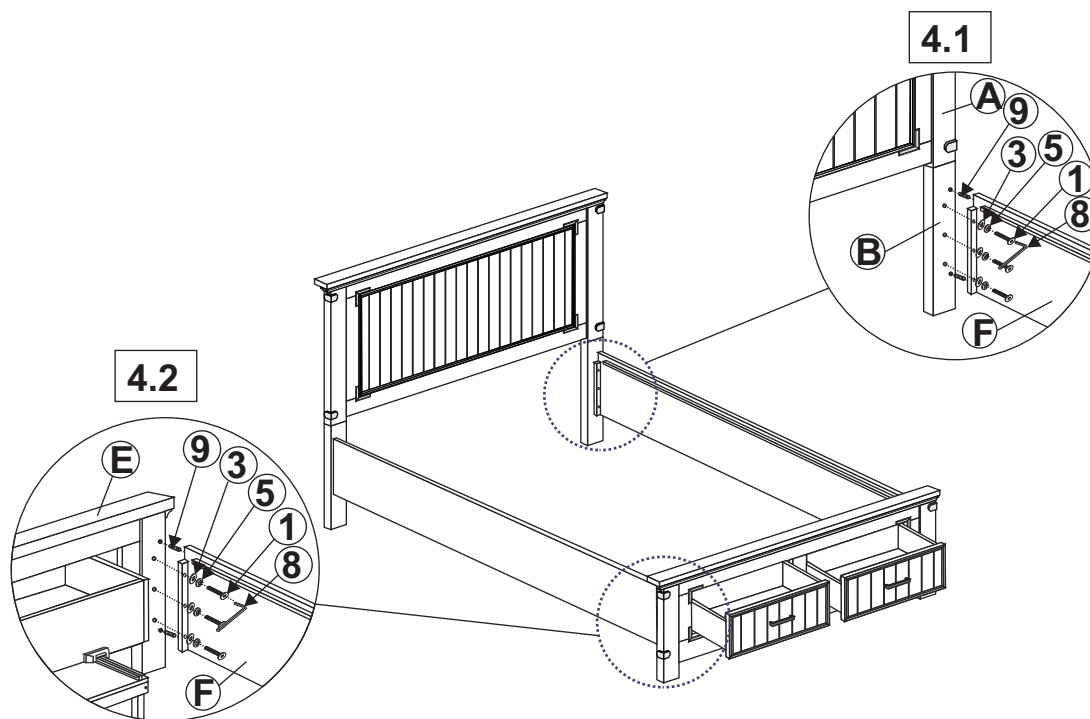

ITEM: 205260KW (B1 - B3)

ASSEMBLY INSTRUCTIONS



STEP 5

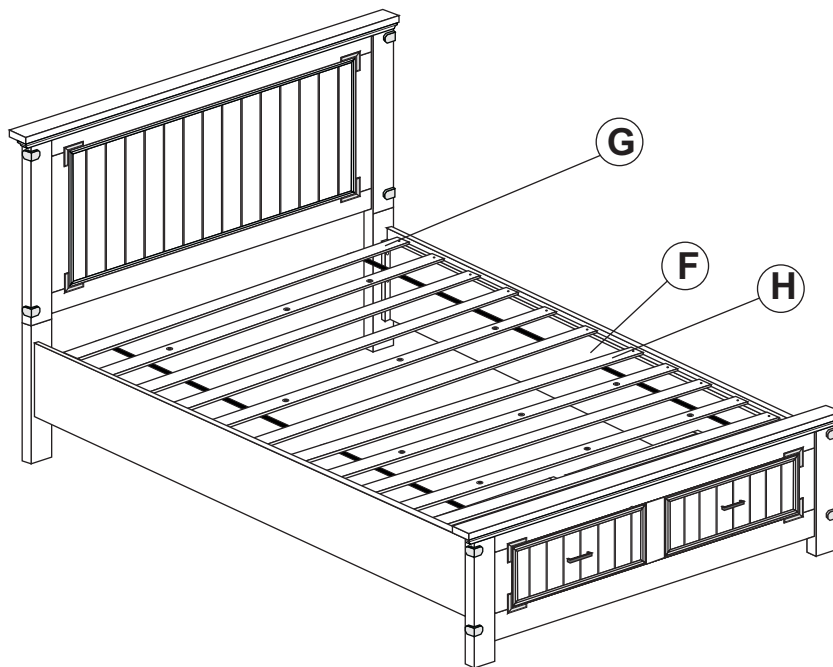

STEP 6

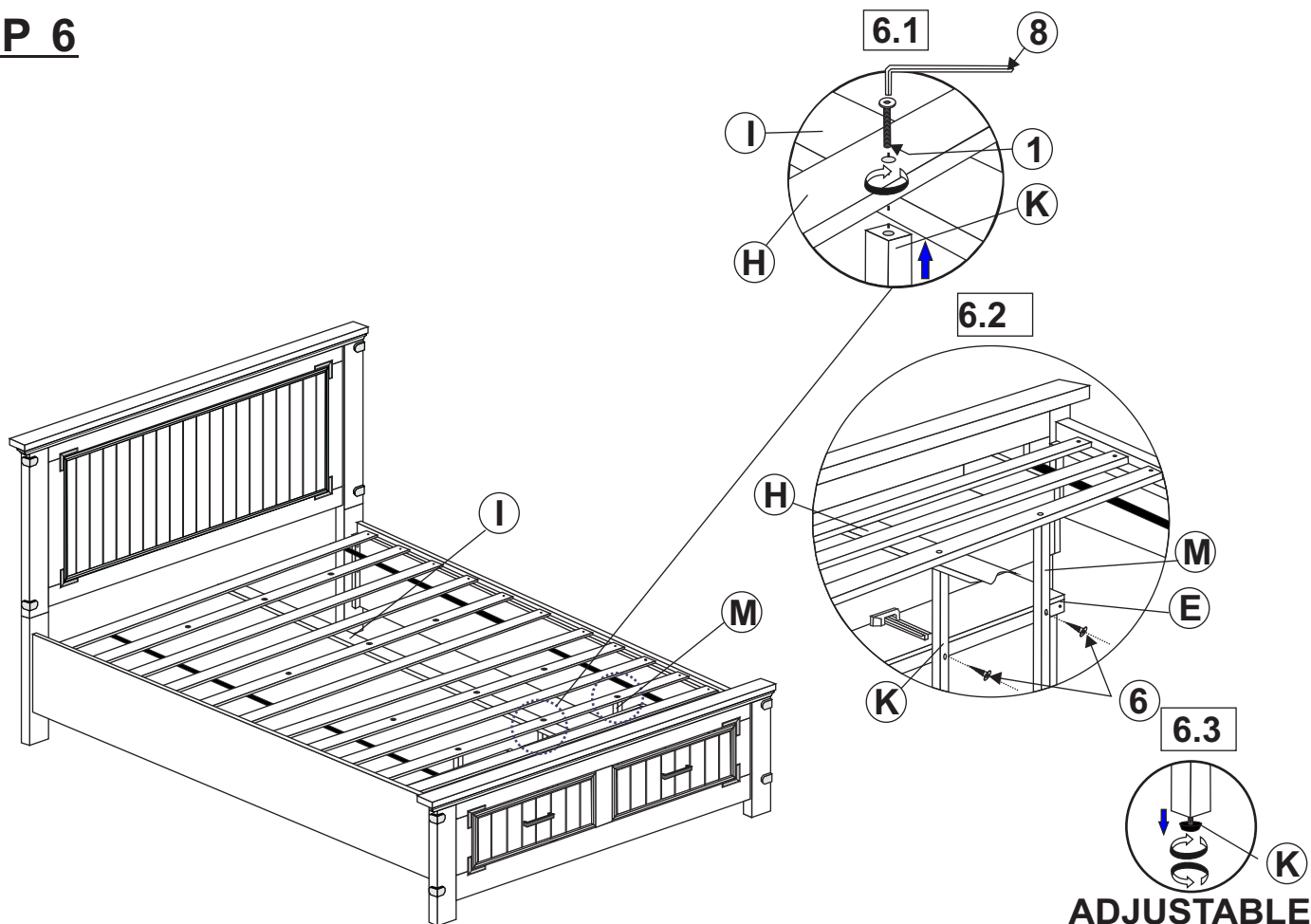

ADJUSTABLE
LEVELER

ITEM: 205260KW (B1 - B3)

ASSEMBLY INSTRUCTIONS



STEP 7

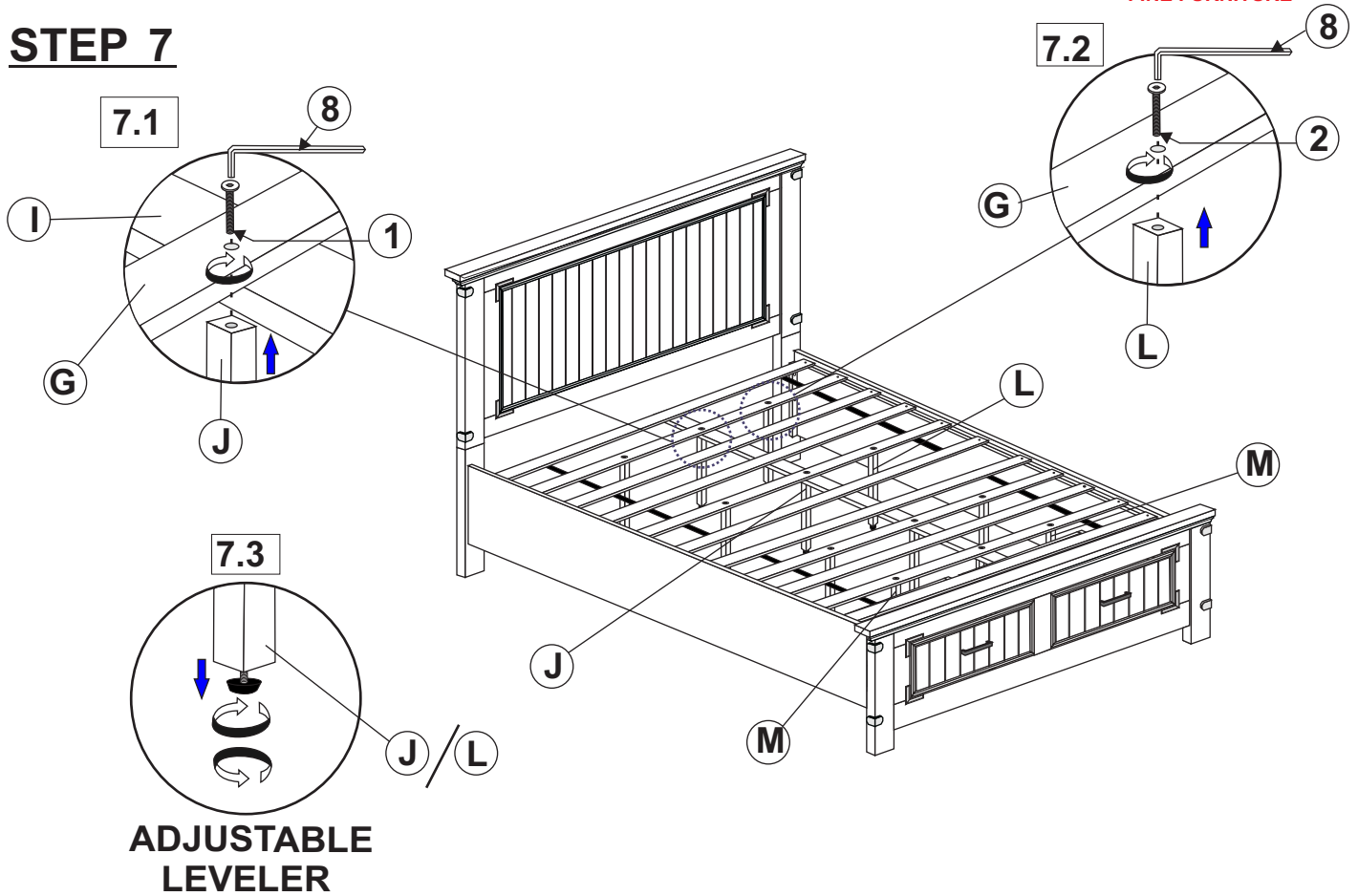

STEP 8

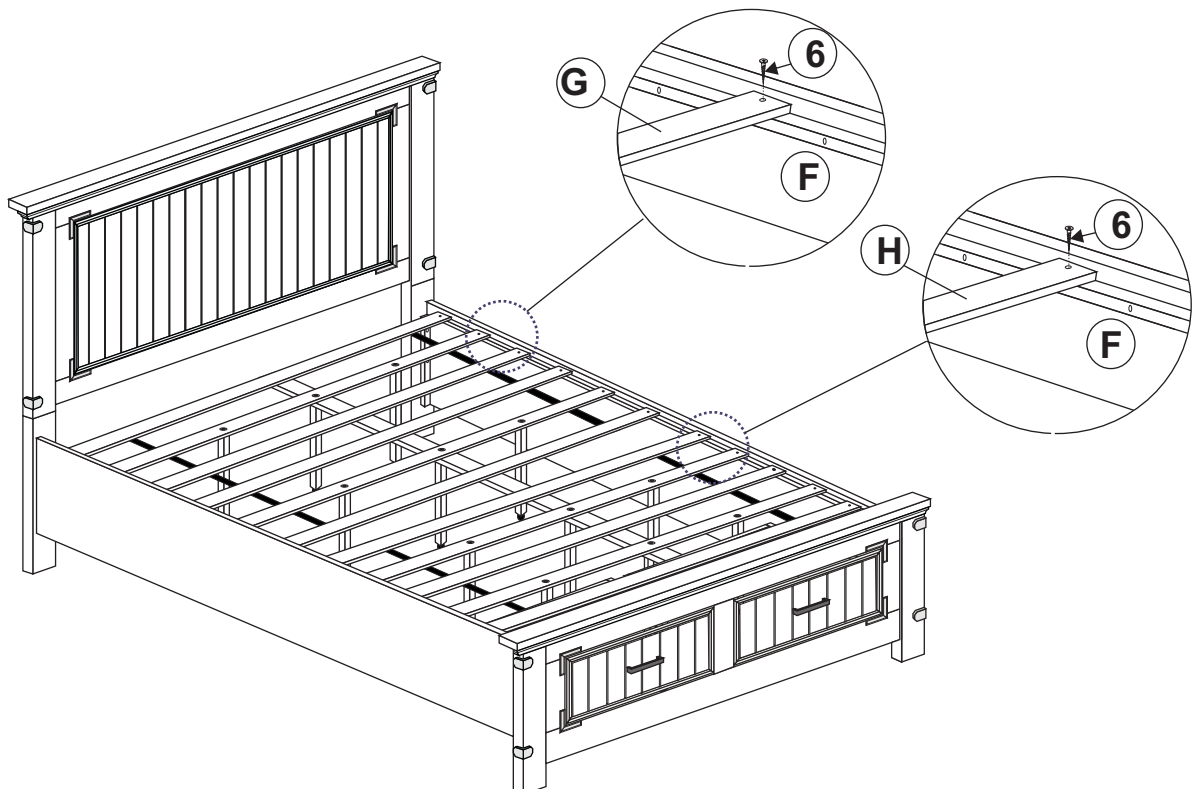

ITEM: 205260KW (B1 - B3)

ASSEMBLY INSTRUCTIONS



STEP 9

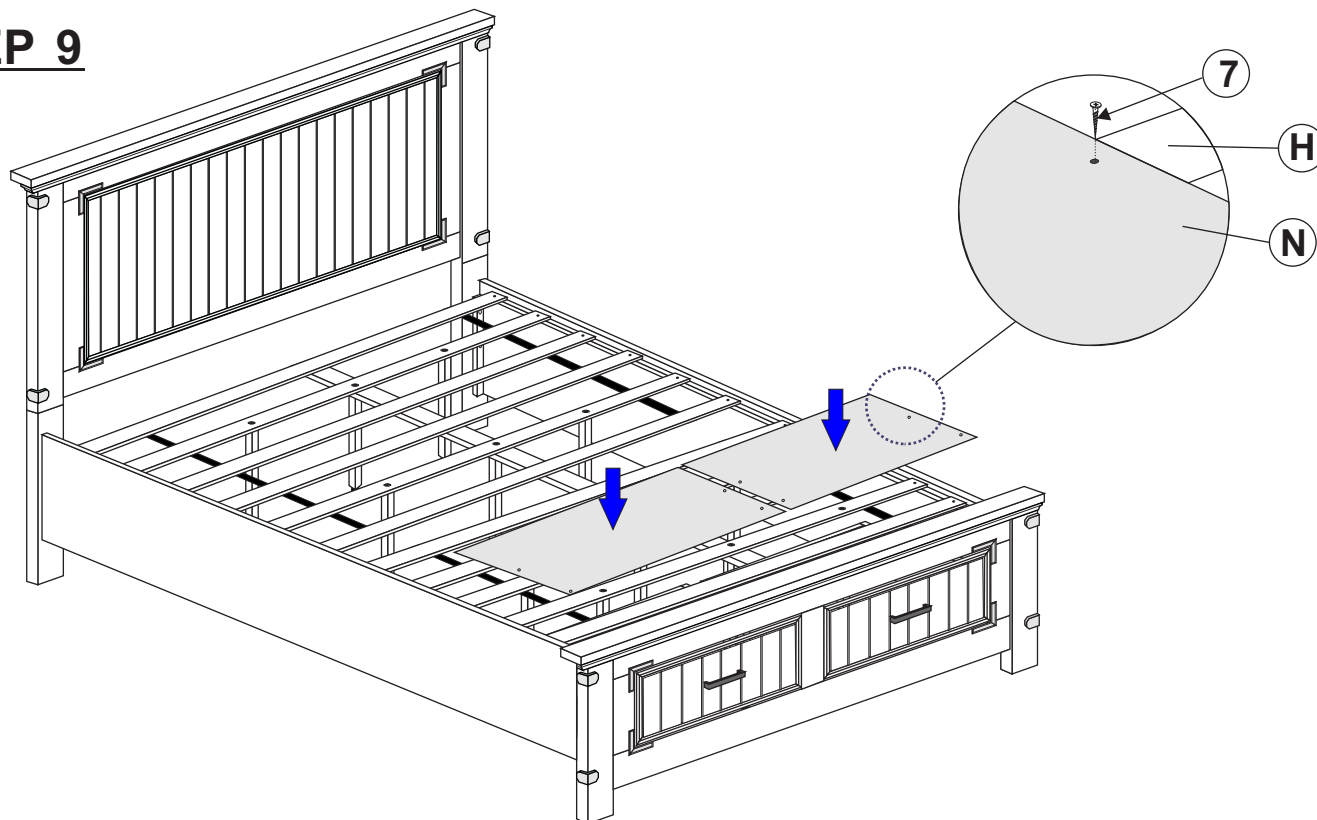

STEP 10 COMPLETE

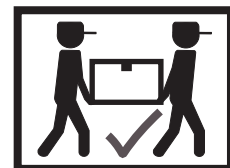
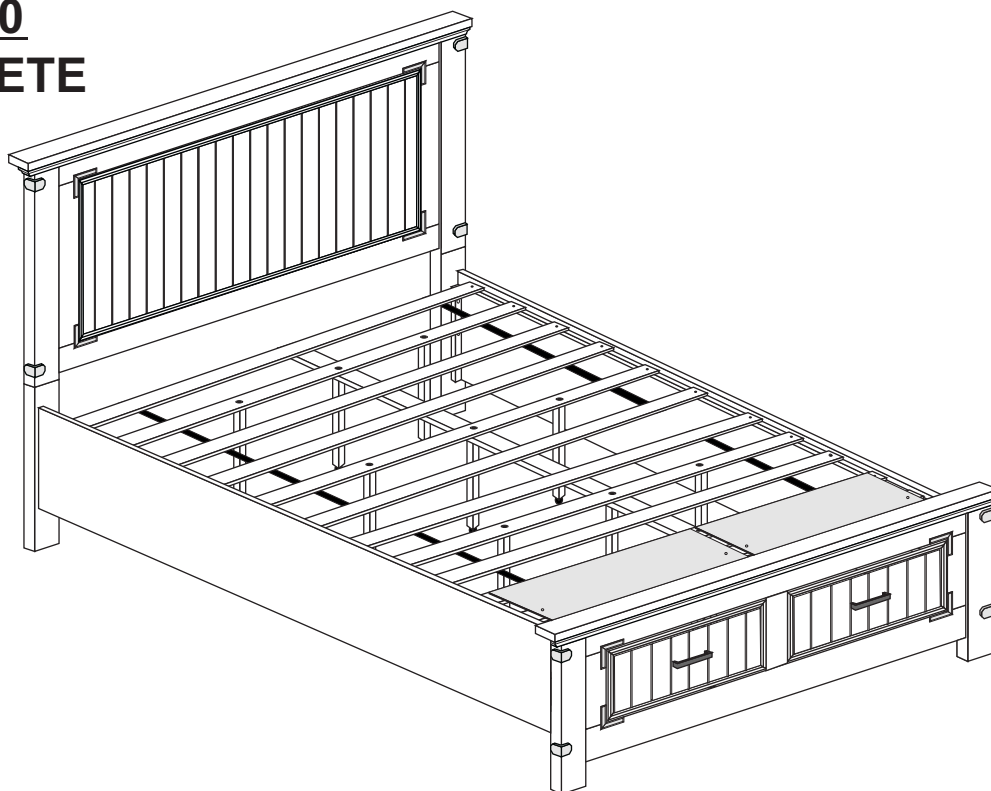

ITEM: 205260KW (B1 - B3)

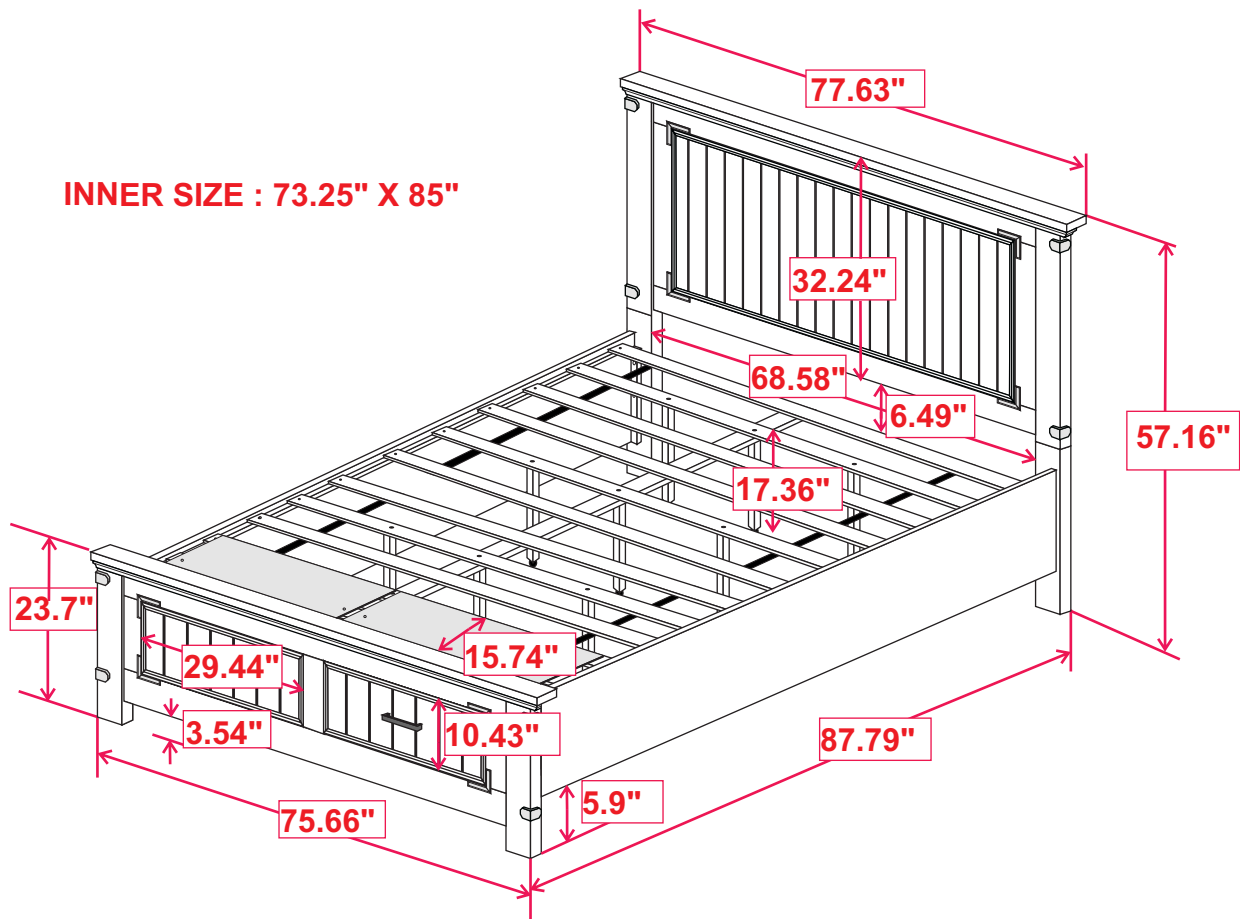

Note : Dimension tolerance $\pm 5\%$