

ASSEMBLY INSTRUCTIONS
COASTER FINE FURNITURE

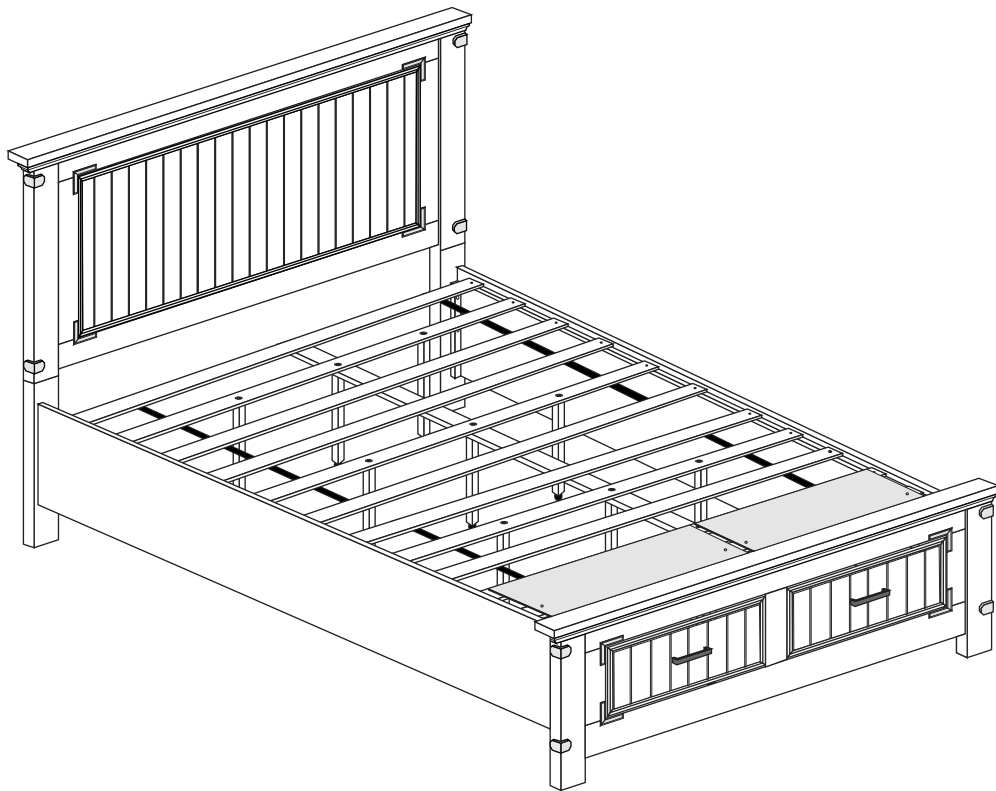

Fine Furniture for every stage of life

205260KE (B1-B3)
Eastern King Storage Bed

REVISION 0:07/27/2016

REVISION 1:11/20/2018

REVISION 2:11/08/2019

COASTERFURNITURE.COM

ITEM: 205260KE (B1 - B3)



ASSEMBLY INSTRUCTIONS

ASSEMBLY TIPS:

- 1 . Remove hardware from box and sort by size.
- 2 . Please check to see that all hardware and parts are present prior to start of assembly
- 3 . Please follow attached instructions in the same sequence as numbered to assure fast & easy assembly.



WARNING!

- 1 . Don't attempt to repair or modify parts that are broken or defective. Please contact the store immediately.
- 2 . This product is for home use only and not intended for commercial establishments.

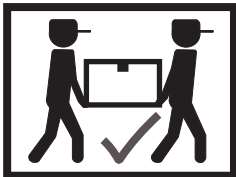

ASSEMBLY TIME

40 MINUTES

PARTS IDENTIFICATION

B1 (BOX 1)

A HEADBOARD PANEL



1PC

B RIGHT HEADBOARD LEG



1PC

C LEFT HEADBOARD LEG

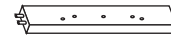

1PC

D WOOD CLEAT

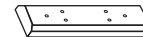

2PCS

B2 (BOX 2)

E STORAGE FOOTBOARD

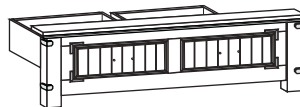

1PC

B3 (BOX 3)

F BED RAIL



2PCS

G HEADBOARD ROLL SLAT (6PCS)



1SET

H FOOTBOARD ROLL SLAT (6PCS)



1SET

I CENTER RAIL



1PC

J CENTER RAIL SUPPORT WITH LEVELER (WITHOUT HOLE)



3PCS

K CENTER RAIL SUPPORT WITH LEVELER (WITH HOLE)



1PC

L BED SLAT SUPPORT WITH LEVELER (WITHOUT HOLE)



6PCS

M BED SLAT SUPPORT WITH LEVELER (WITH HOLE)



2PCS

N CONCEAL PANEL



2PCS

HB 205260KE (B1) FROM BOX 1 HEADBOARD COMPLETE



1PC

E 205260KE (B2) FROM BOX 2 STORAGE FOOTBOARD



1PC

ITEM:205260KE (B1 - B3)

ASSEMBLY INSTRUCTIONS



ASSEMBLY TIPS:

- 1 . Remove hardware from box and sort by size.
- 2 . Please check to see that all hardware and parts are present prior to start of assembly
- 3 . Please follow attached instructions in the same sequence as numbered to assure fast & easy assembly.











WARNING!

- 1 . Don't attempt to repair or modify parts that are broken or defective. Please contact the store immediately.
- 2 . This product is for home use only and not intended for commercial establishments.

HARDWARE IDENTIFICATION

Z-B3 (BOX 3) - HARDWARE PACK IS LOCATED IN 205260KE (B3)

1	LONG BOLT (M6 x 60mm - RBW)		16PCS
2	SHORT BOLT (M6 x 40mm - RBW)		20PCS
3	BIG FLAT WASHER (M6 x 19mm - RBW)		12PCS
4	SMALL FLAT WASHER (M6 x 13mm - RBW)		12PCS
5	LOCK WASHER (M6 x 13mm - RBW)		24PCS
6	LONG FLAT HEAD SCREW (M4 x 30mm - RBW)		27PCS
7	SHORT FLAT HEAD SCREW (M4 x 16mm - RBW)		8PCS
8	ALLEN WRENCH (M4 x 58mm- BLK)		1PC
9	WOOD DOWEL (Ø 10 x 30mm)		8PCS

NOTE :

Phillips head screw driver is required in the assembly process; however, manufacturer does not provide this item.

ITEM: 205260KE (B1 - B3)

ASSEMBLY INSTRUCTIONS



STEP 1

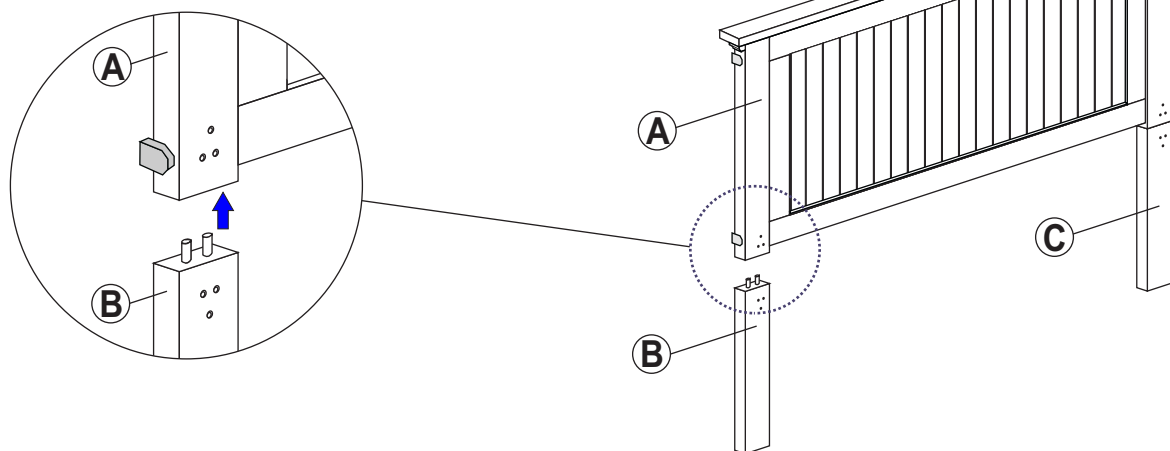

STEP 2

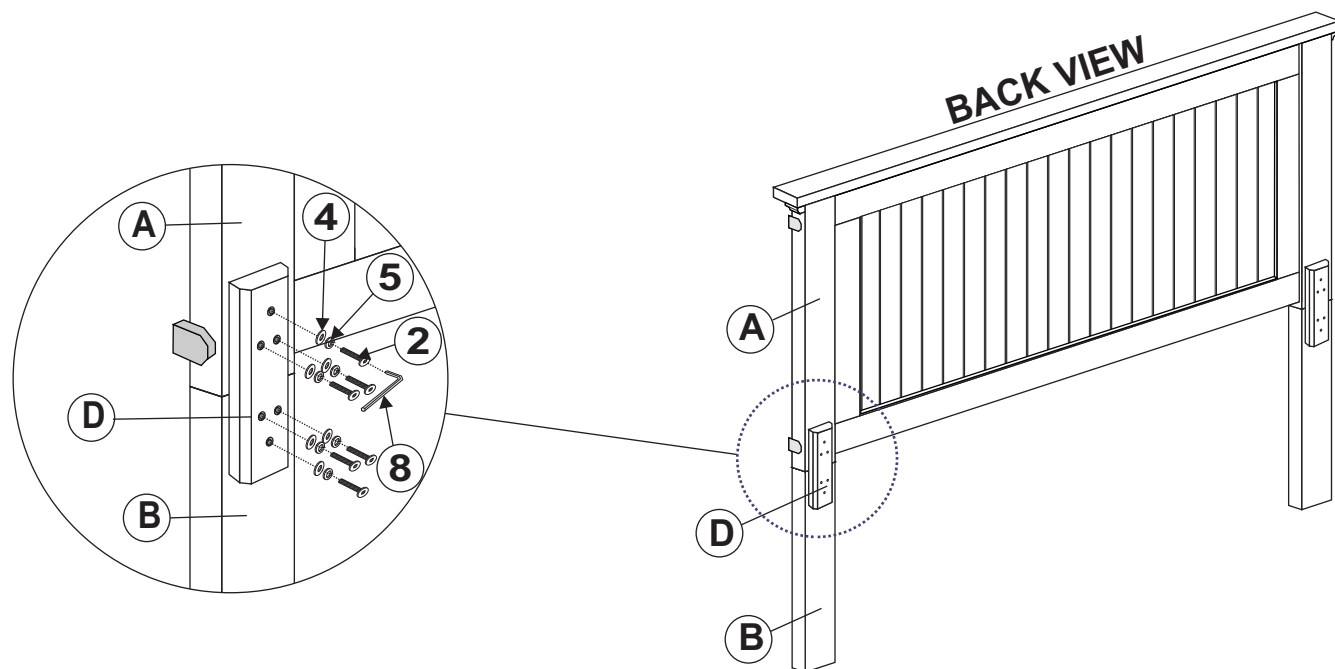

ITEM: 205260KE (B1 - B3)

ASSEMBLY INSTRUCTIONS



STEP 3

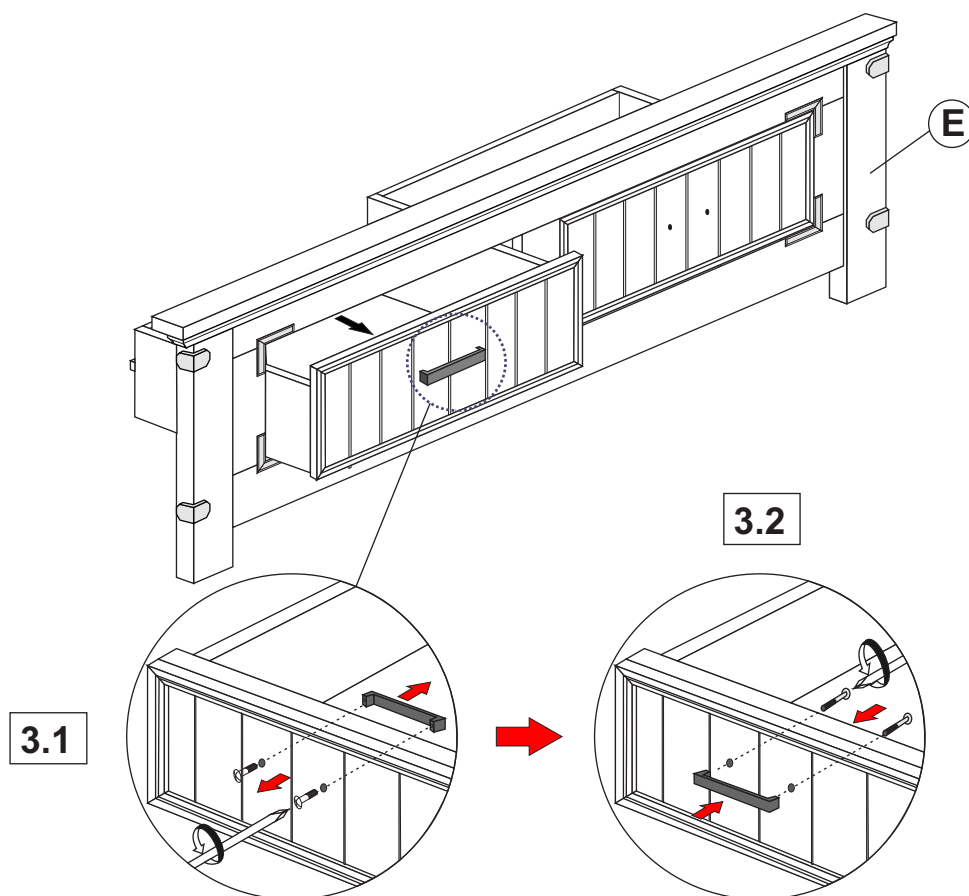

STEP 4

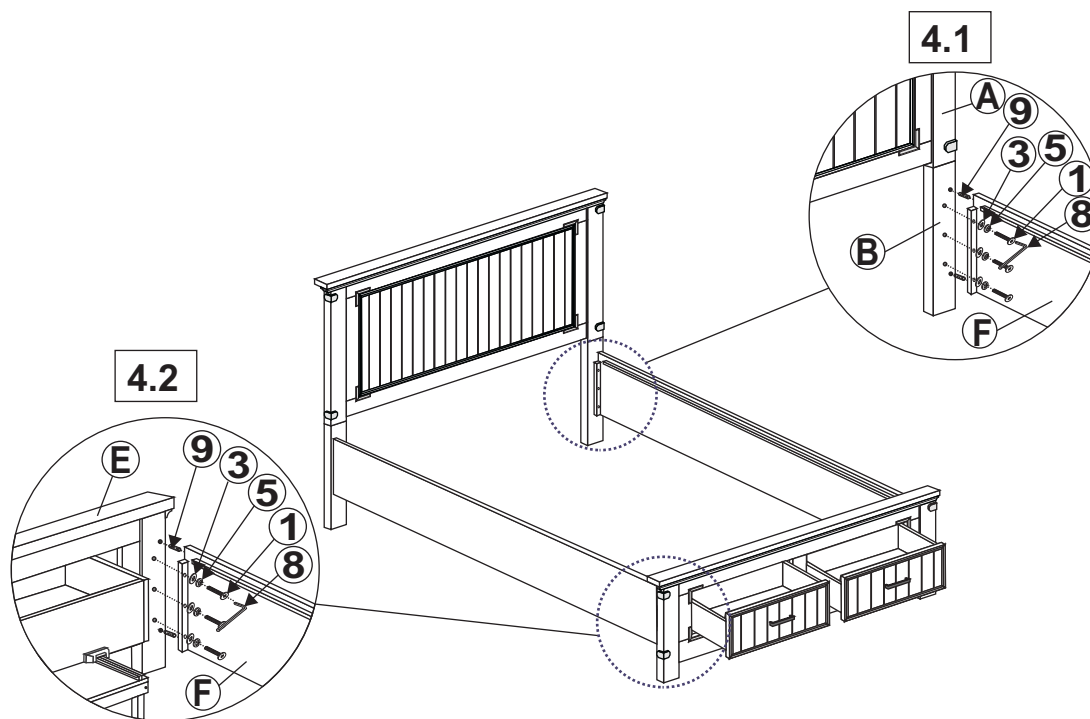

ITEM: 205260KE (B1 - B3)

ASSEMBLY INSTRUCTIONS



STEP 5

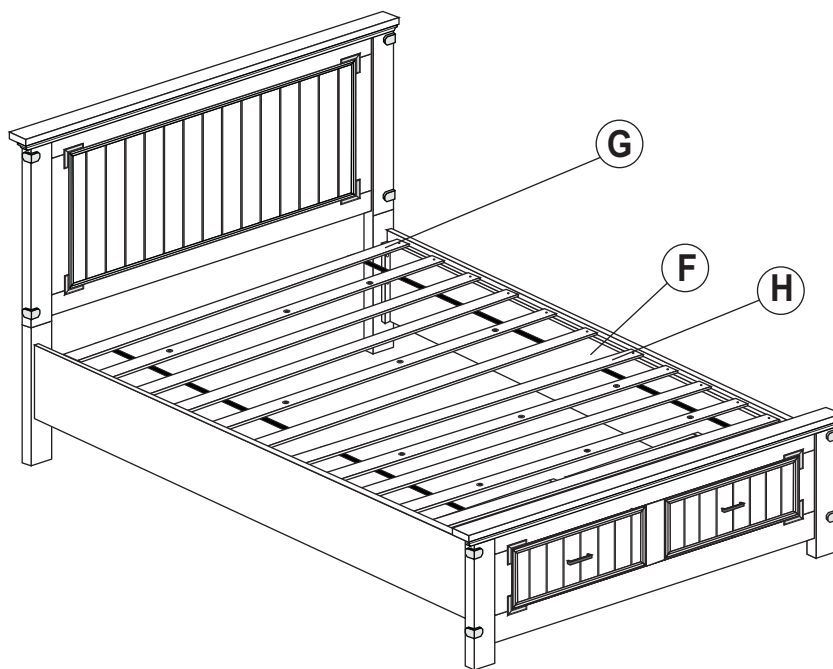

STEP 6

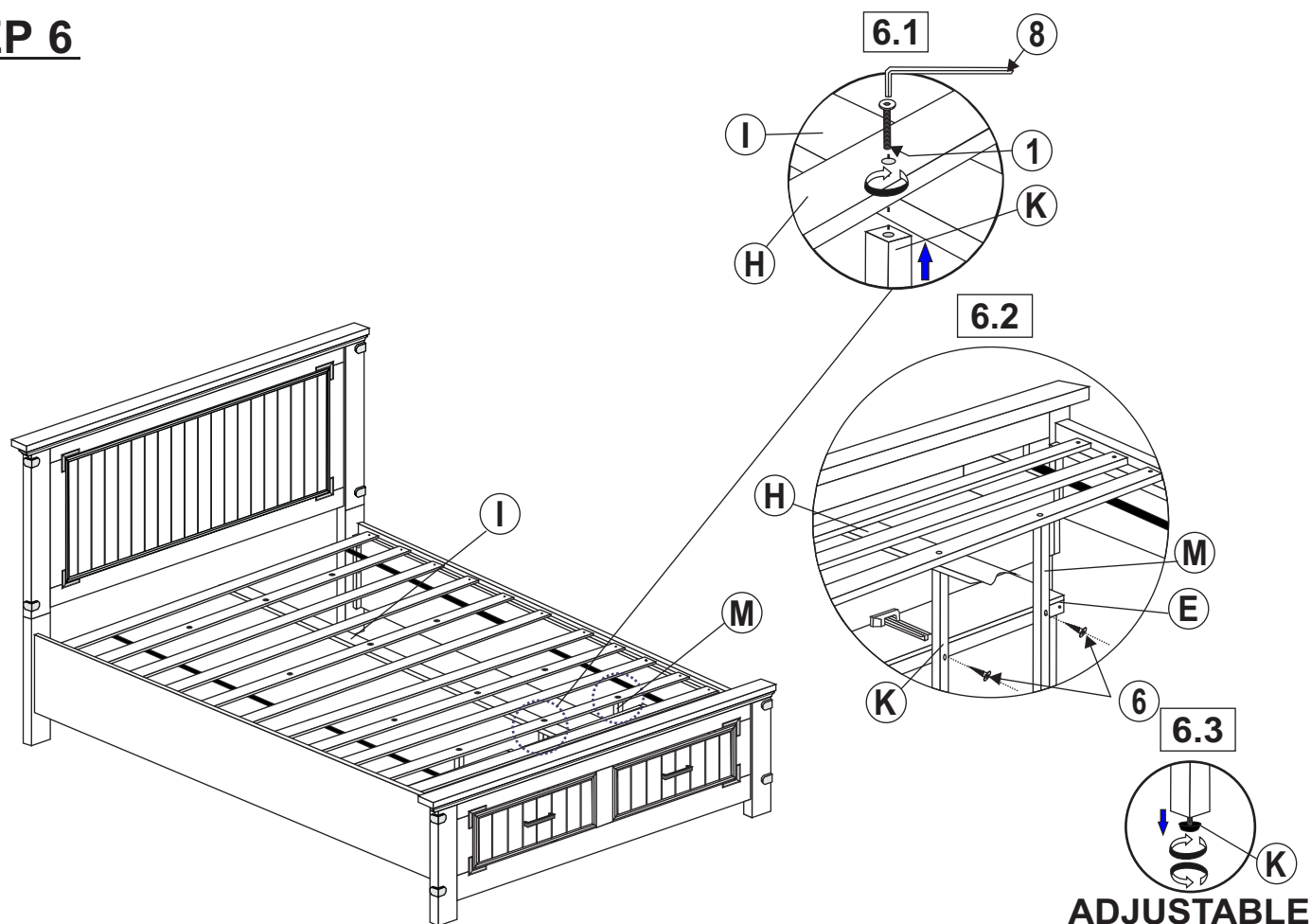

**ADJUSTABLE
LEVELER**

ITEM: 205260KE (B1 - B3)

ASSEMBLY INSTRUCTIONS



STEP 7

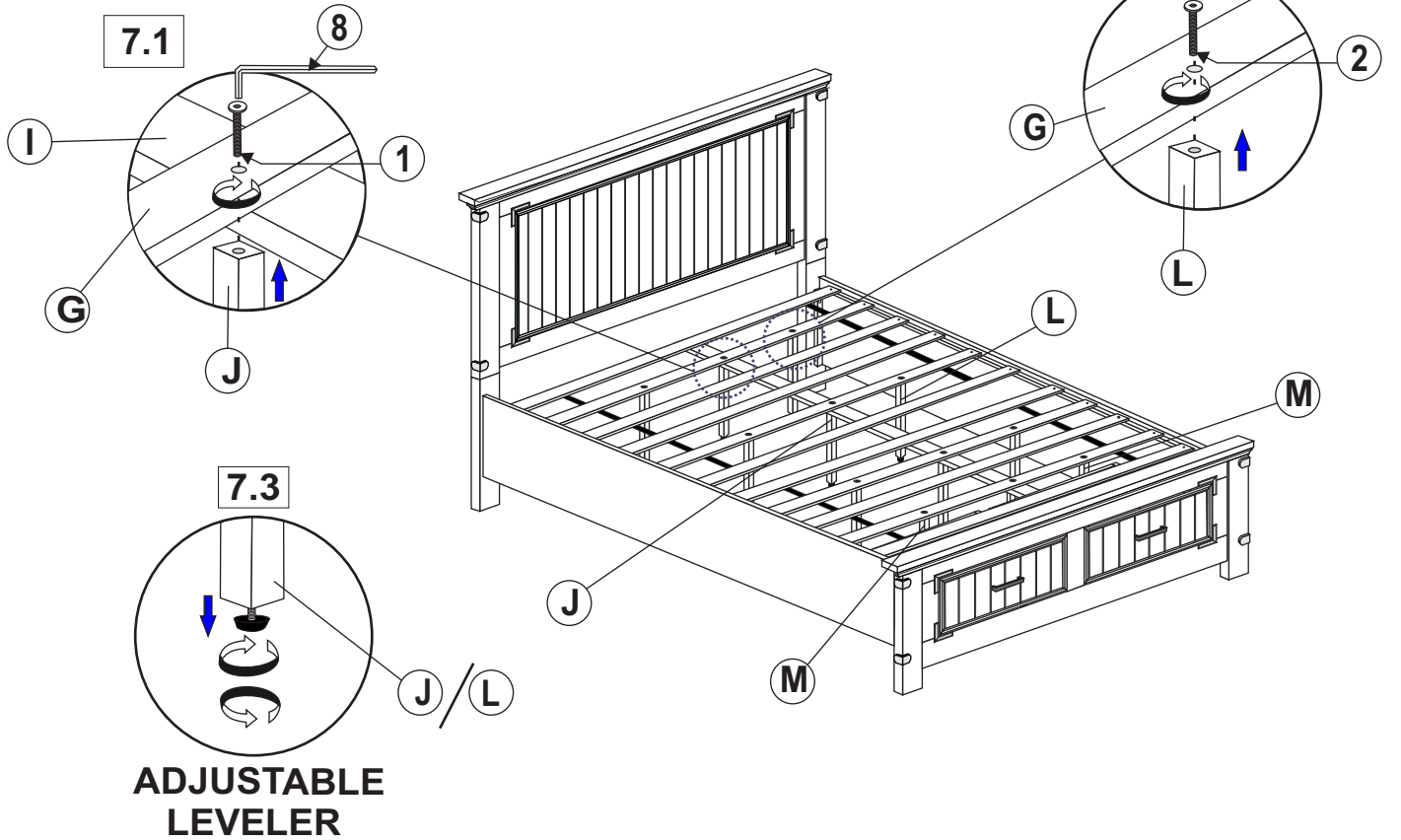

STEP 8

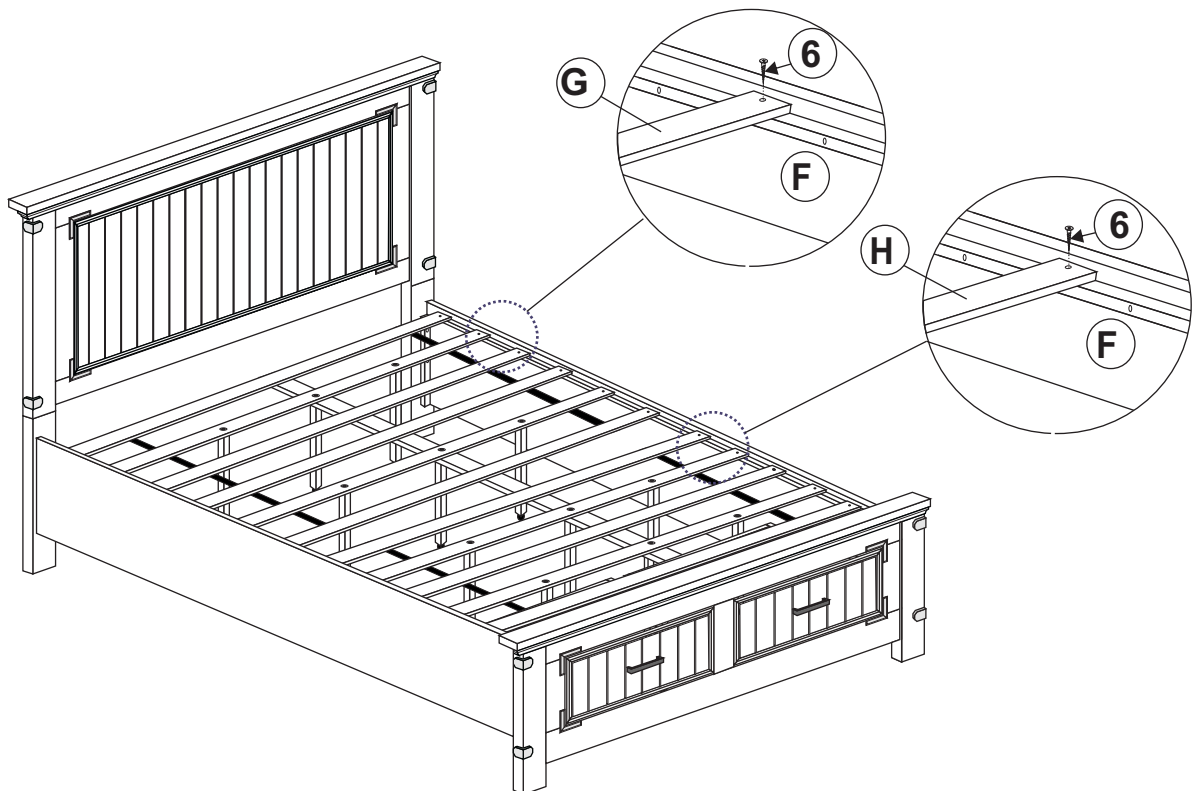

ITEM: 205260KE (B1 - B3)

ASSEMBLY INSTRUCTIONS



STEP 9

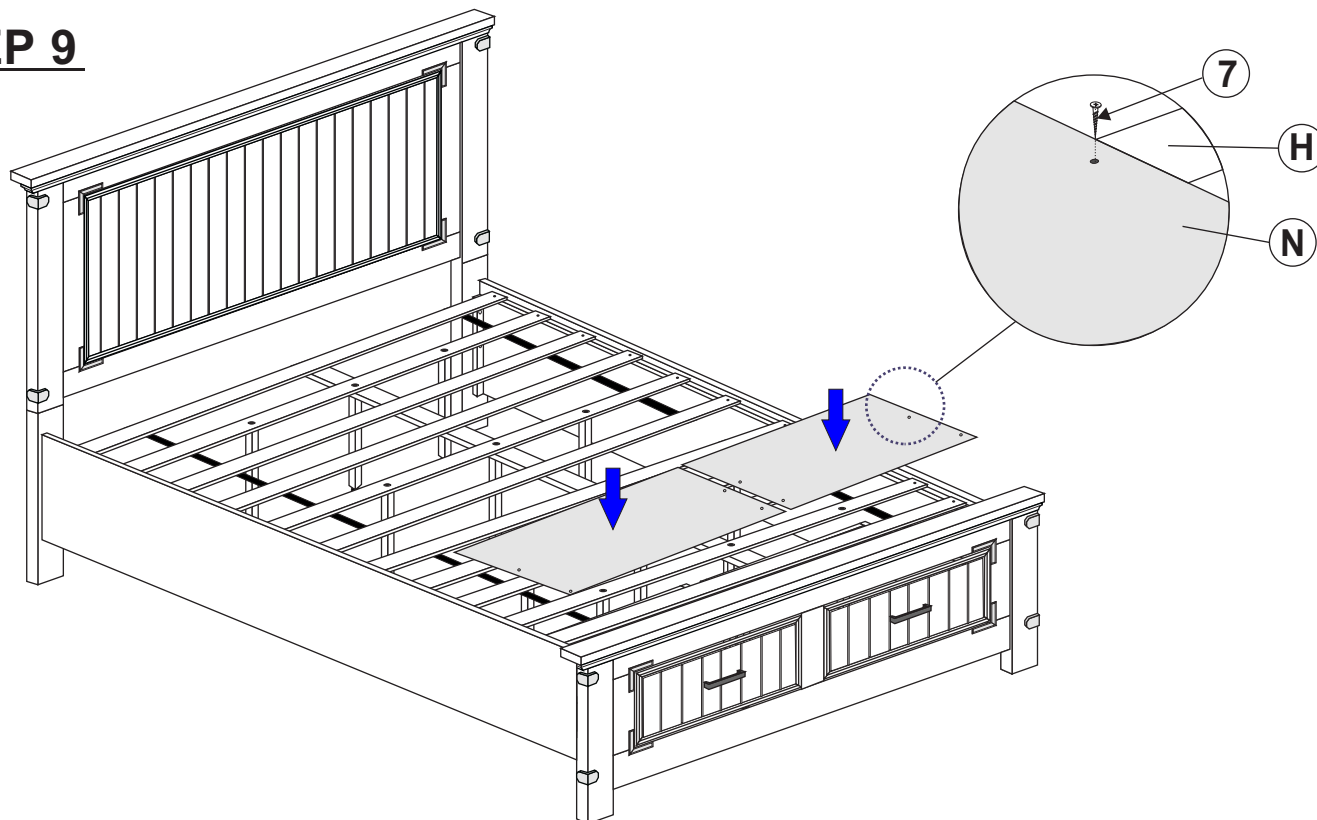

STEP 10 COMPLETE

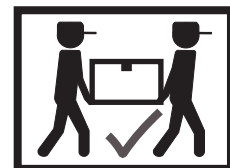
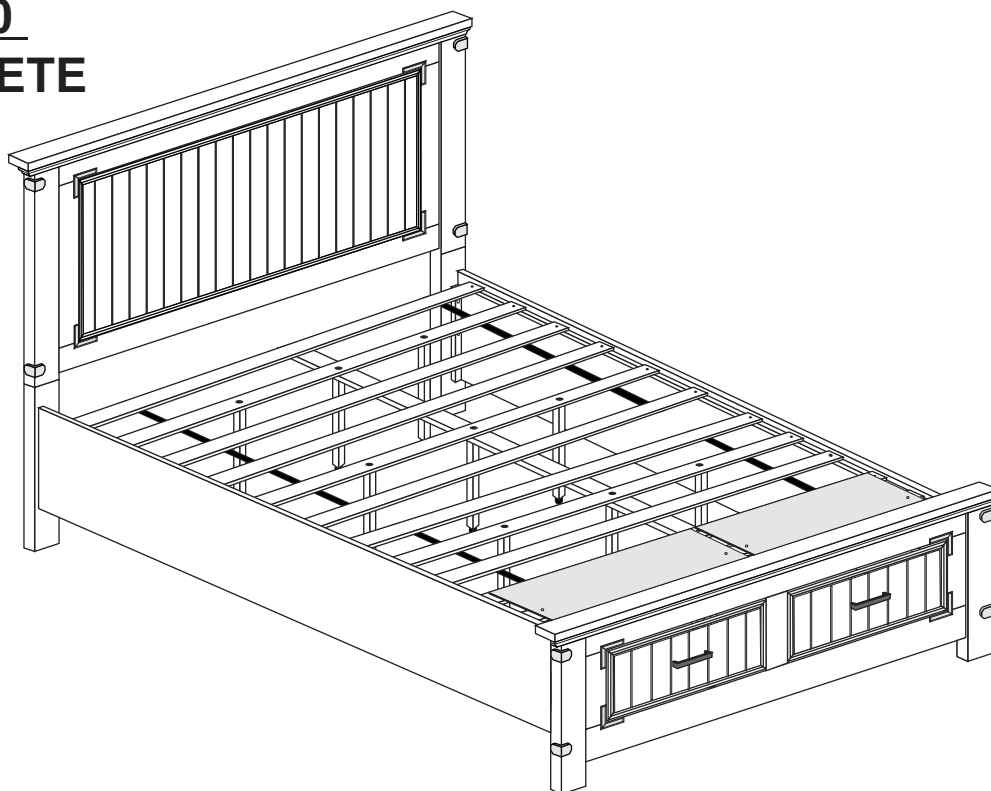

ITEM:205260KE (B1 - B3)

COASTER[®]
FINE FURNITURE

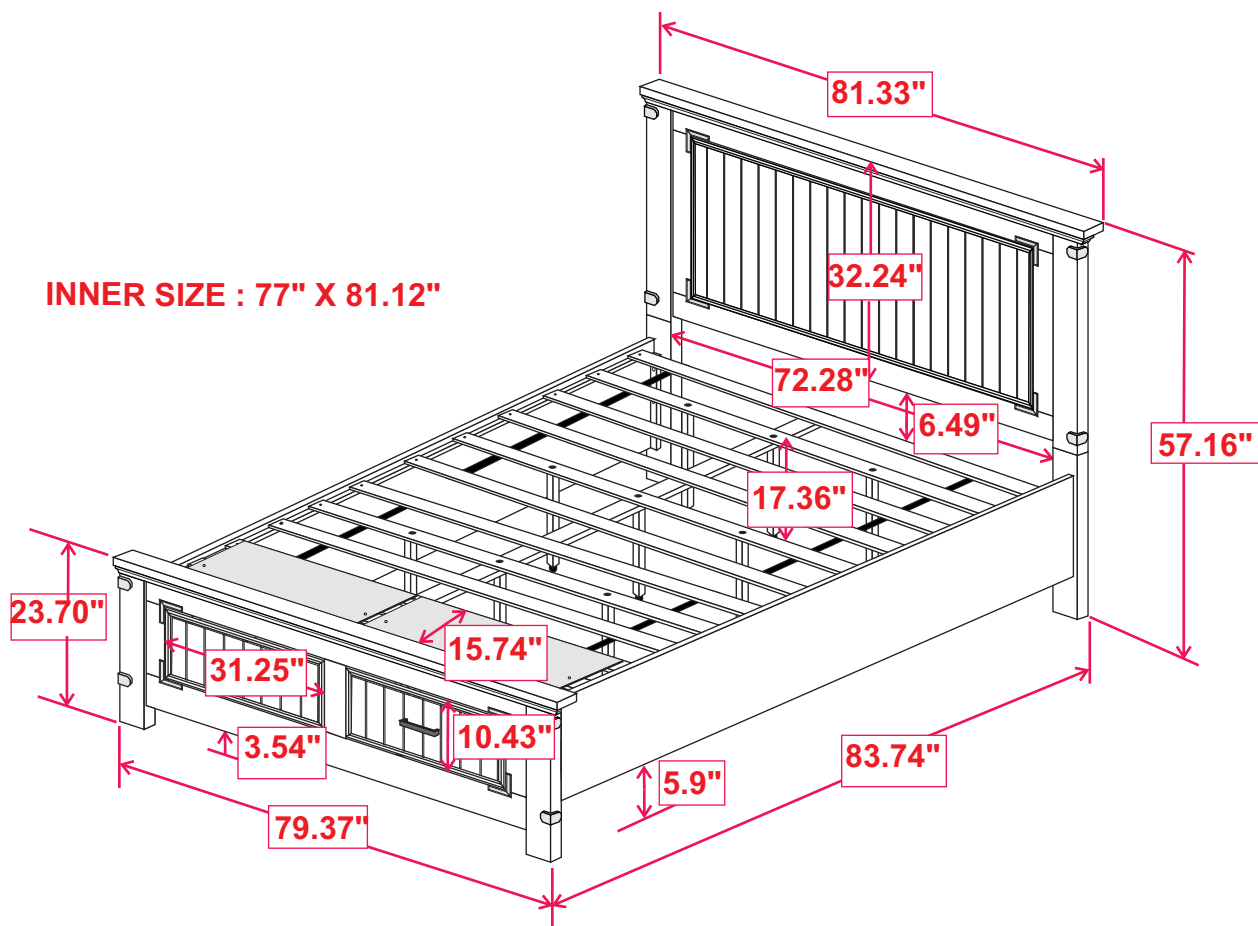

Note : Dimension tolerance $\pm 5\%$