

**ASSEMBLY INSTRUCTIONS**  
**COASTER FINE FURNITURE**



*Fine Furniture for every stage of life*

**201309KE (B1-B3)**  
***Eastern King***  
***Storage Bed***

REVISION 0 : 06/03/2011  
REVISION 1 : 09/27/2011  
REVISION 2 : 07/17/2012  
REVISION 3 : 08/29/2012  
REVISION 4 : 11/28/2012  
REVISION 5 : 03/17/2016  
REVISION 6 : 08/14/2018  
REVISION 7 : 10/17/2019

# ITEM: 201309KE (B1-B3)



## ASSEMBLY INSTRUCTIONS

### ASSEMBLY TIPS:

1. Remove hardware from box and sort by size.
2. Please check to see that all hardware and parts are present prior to start of assembly.
3. Please follow attached instructions in the same sequence as numbered to assure fast & easy assembly.



### WARNING!

1. Don't attempt to repair or modify parts that are broken or defective. Please contact the store immediately.
2. This product is for home use only and not intended for commercial establishments.

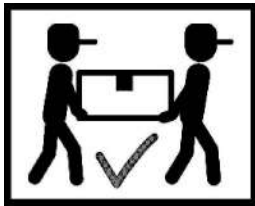

ASSEMBLY TIME

35 MINUTES

## PARTS IDENTIFICATION

### B1 ( BOX 1 )

A HEADBOARD PANEL



1PC

B1 LEFT HEADBOARD LEG



1PC

B2 RIGHT HEADBOARD LEG



1PC

H HEADBOARD BOTTOM RAIL



1PC

### B2 ( BOX 2 )

C STORAGE FOOTBOARD

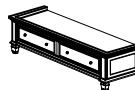

1PC

E CENTER RAIL SUPPORT WITH LEVELER



2PCS

F CENTER RAIL



1PC

G ROLL SLAT  
(12PCS)

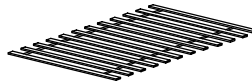

1SET

### B3 ( BOX 3 )

D1 LEFT BED RAIL



1PC

D2 RIGHT BED RAIL



1PC

HB 201309KE (B1)  
FROM BOX 1  
HEADBOARD COMPLETE



1PC

C 201309KE (B2)  
FROM BOX 2  
STORAGE FOOTBOARD

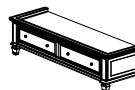

1PC

# ITEM: 201309KE (B1-B3)



## ASSEMBLY INSTRUCTIONS

### ASSEMBLY TIPS:

1. Remove hardware from box and sort by size.
2. Please check to see that all hardware and parts are present prior to start of assembly.
3. Please follow attached instructions in the same sequence as numbered to assure fast & easy assembly.















### WARNING!

1. Don't attempt to repair or modify parts that are broken or defective. Please contact the store immediately.
2. This product is for home use only and not intended for commercial establishments.

## HARDWARE IDENTIFICATION

### Z-B1 (BOX 1) - HARDWARE PACK IS LOCATED IN 201309KE (B1)

1	<b>ALLEN WRENCH</b> (M4 x 110mm - BLK)		1PC
2	<b>SHORT BOLT</b> (M6 x 35mm - RBW)		8PCS
3	<b>LOCK WASHER</b> (5/16" - RBW)		22PCS
4	<b>FLAT WASHER</b> (5/16" x 18 x 1.2 - RBW)		22PCS
5	<b>WOOD DOWEL</b> (M8 x 30mm)		12PCS
6	<b>LONG FLAT HEAD SCREW</b> (#8 x 1 1/8" - BLK)		24PCS
7	<b>LONG BOLT</b> (M6 x 60mm - RBW)		10PCS
8	<b>MEDIUM BOLT</b> (M6 x 45mm - RBW)		6PCS
9	<b>SHORT FLAT HEAD SCREW</b> (M4 x 20mm - RBW)		8PCS
10	<b>WRENCH</b> (2 x 24.5 x 85 - RBW)		1PC
11	<b>HEX NUT</b> (M6 - RBW)		2PCS
12	<b>U BRACKET</b> (26 x 63 x 70mm - RBW)		2PCS

### NOTE:

Phillips head screw driver is required in the assembly process; however, manufacturer does not provide this item.

ITEM: **201309KE (B1-B3)**



## ASSEMBLY INSTRUCTIONS

### STEP 1

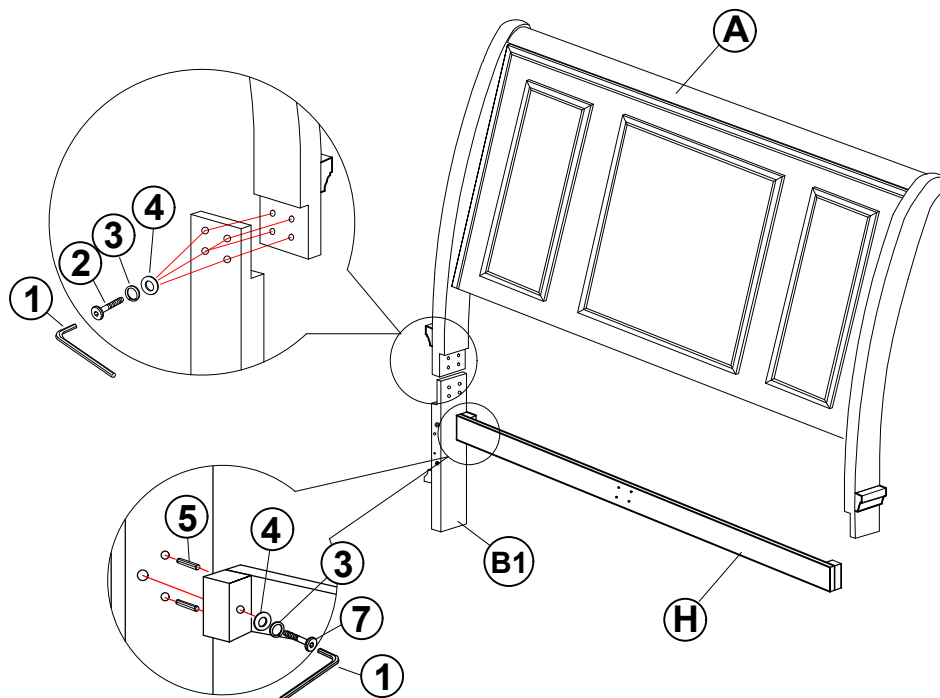

### STEP 2

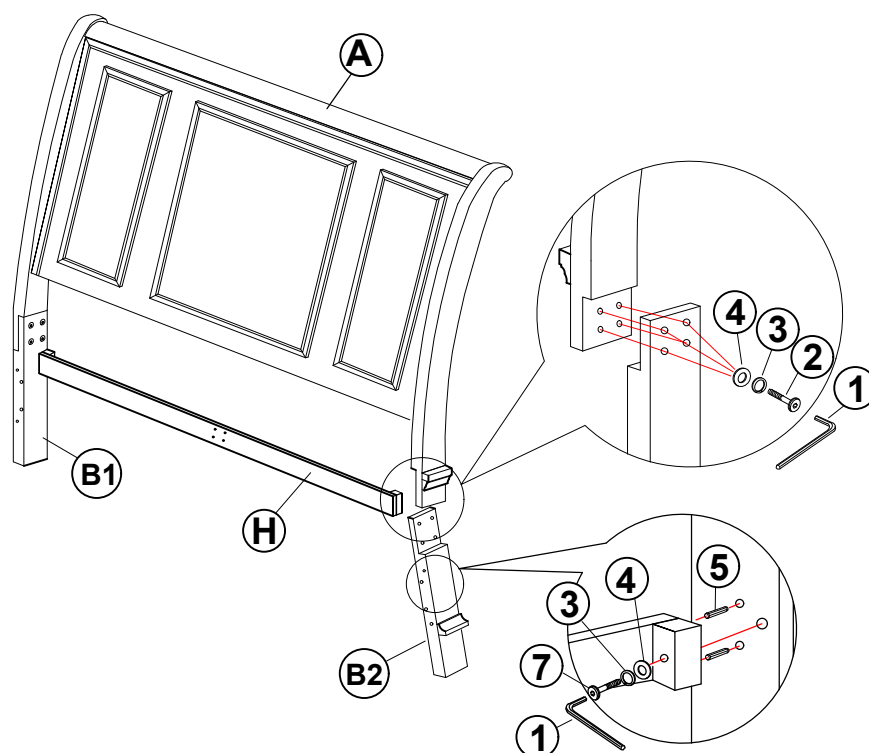

ITEM: **201309KE (B1-B3)**



**ASSEMBLY INSTRUCTIONS**  
**STEP 3**

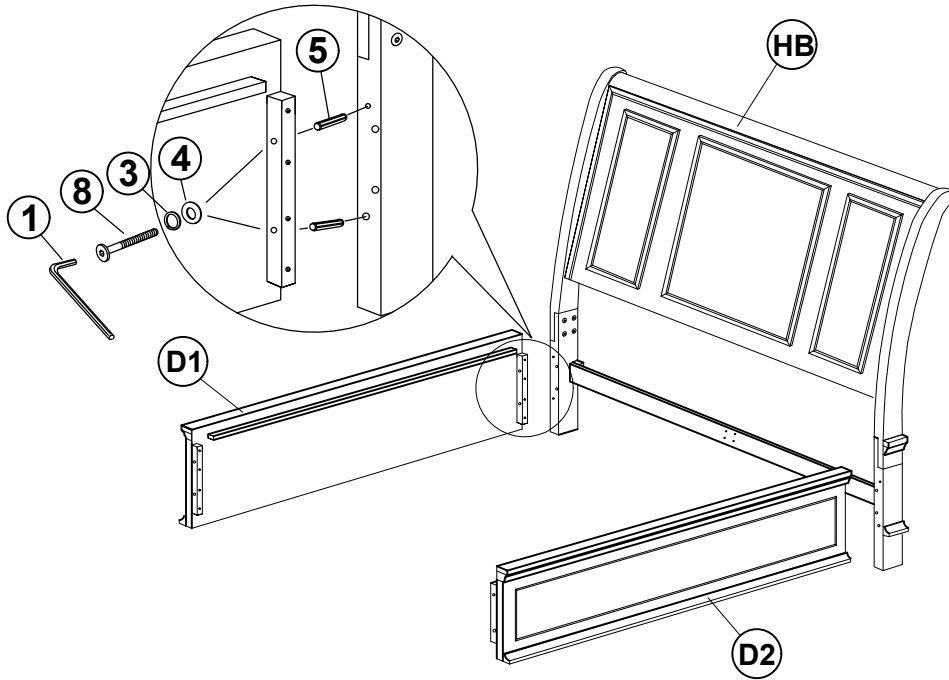

**STEP 4**

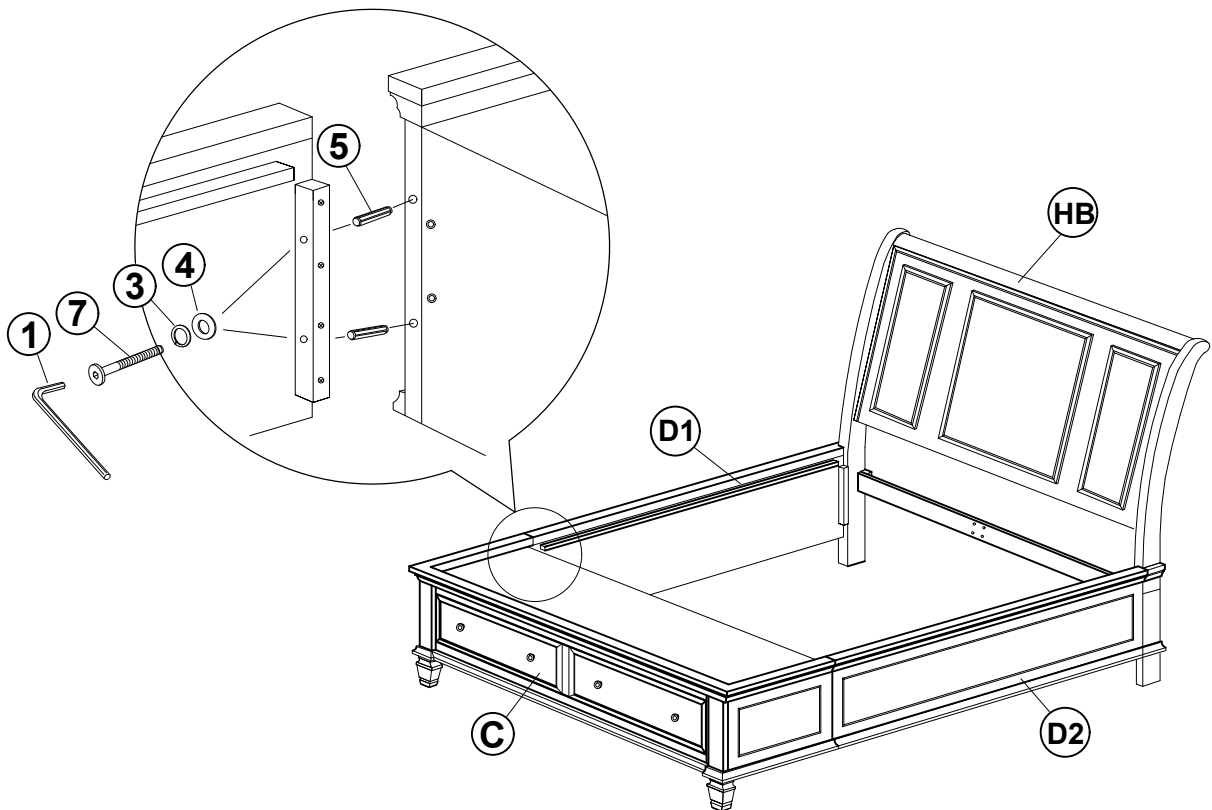

ITEM: 201309KE (B1-B3)



**ASSEMBLY INSTRUCTIONS**  
**STEP 5**

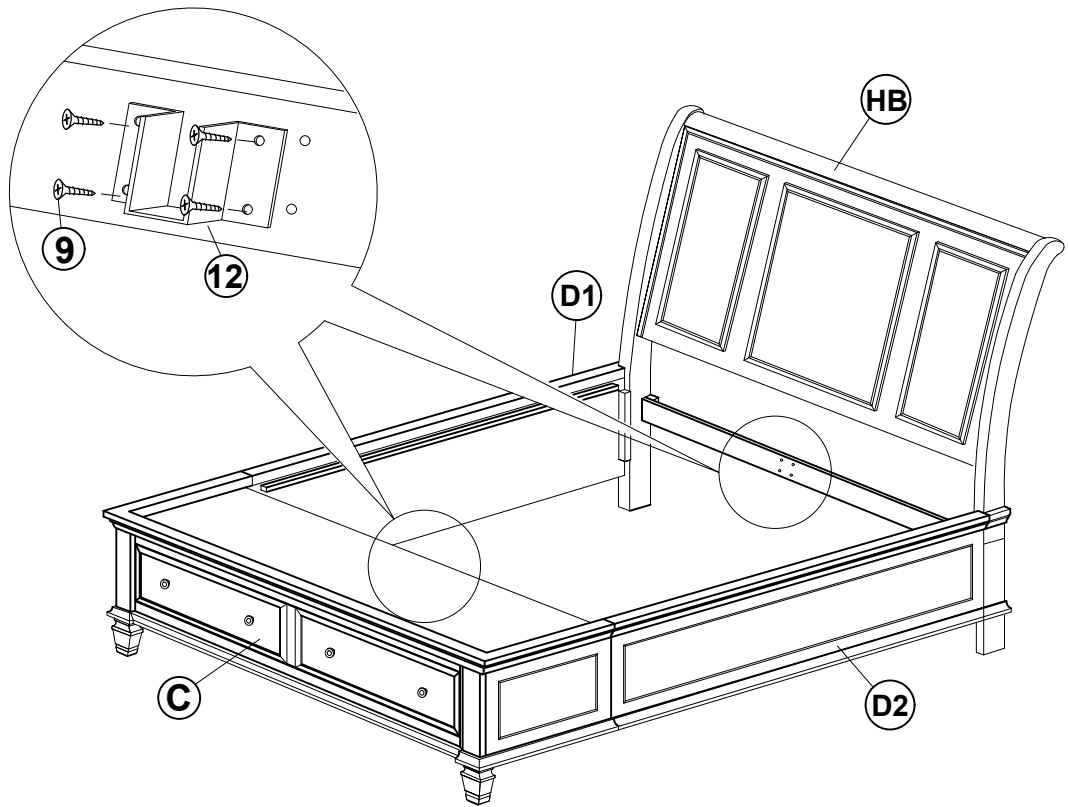

**STEP 6**

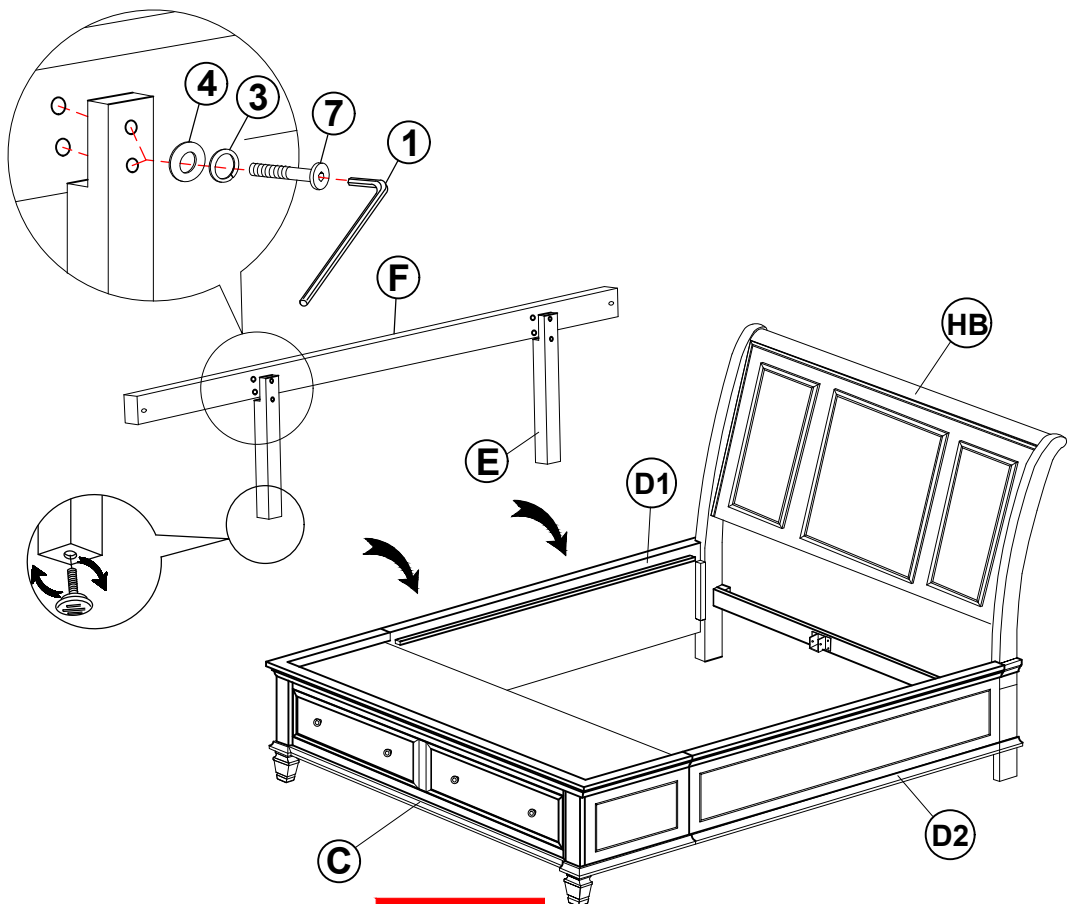

ITEM: 201309KE (B1-B3)



**ASSEMBLY INSTRUCTIONS**  
**STEP 7**

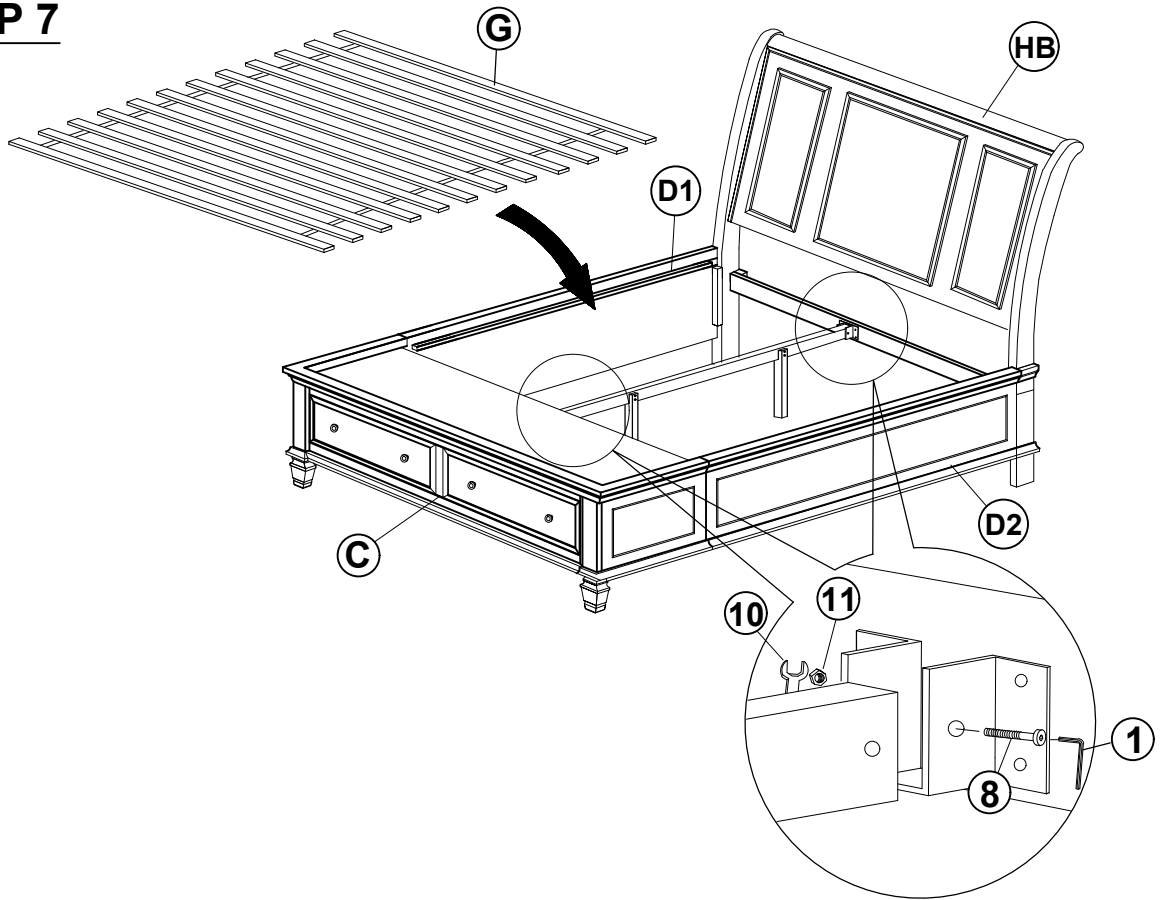

**STEP 8**

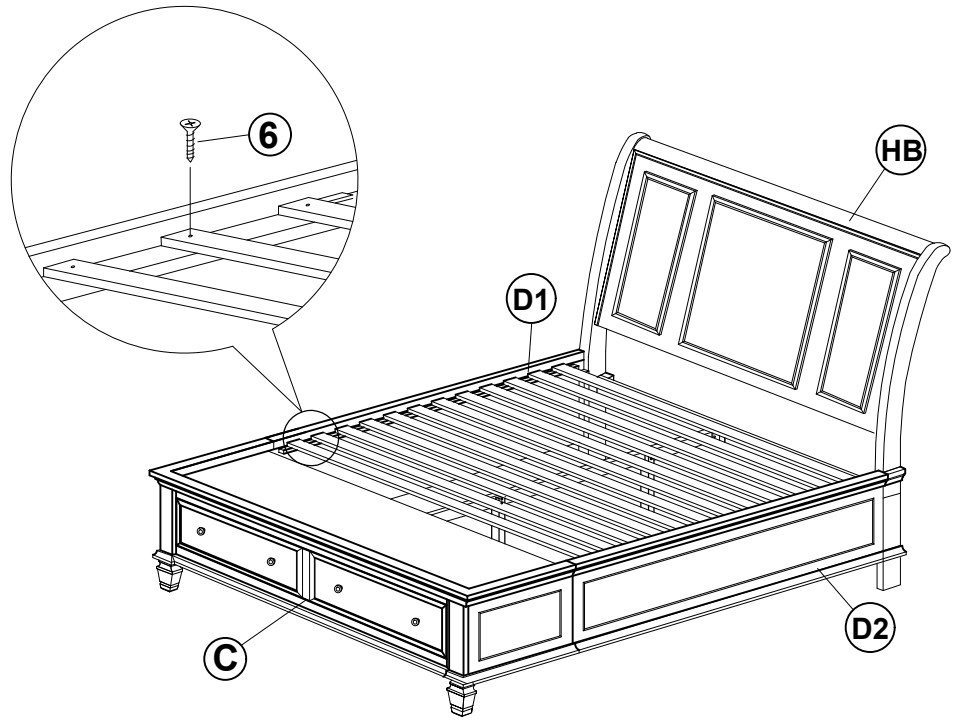

ITEM: **201309KE (B1-B3)**



**ASSEMBLY INSTRUCTIONS**

**STEP 9**

**COMPLETE**

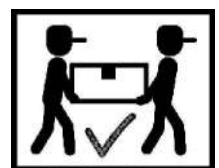
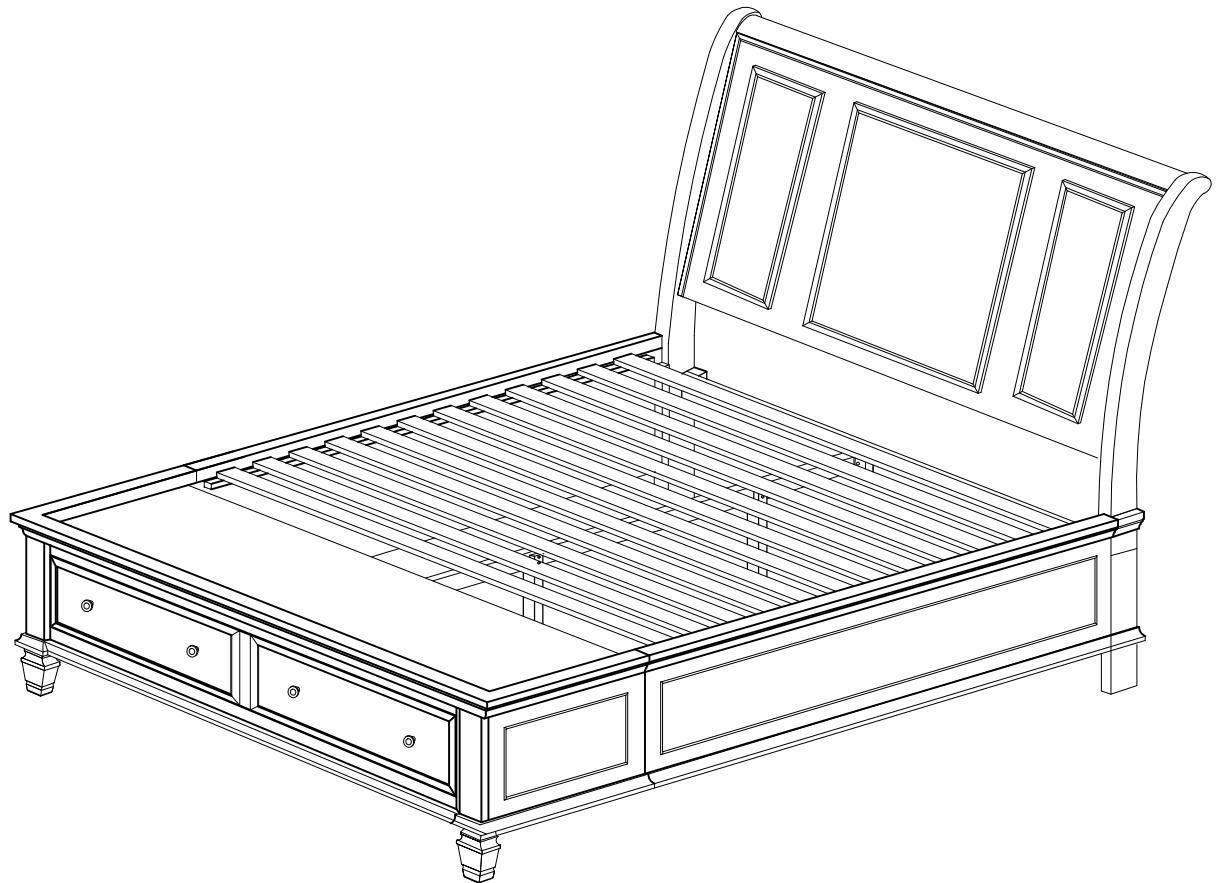



ITEM:201309KE (B1-B3)

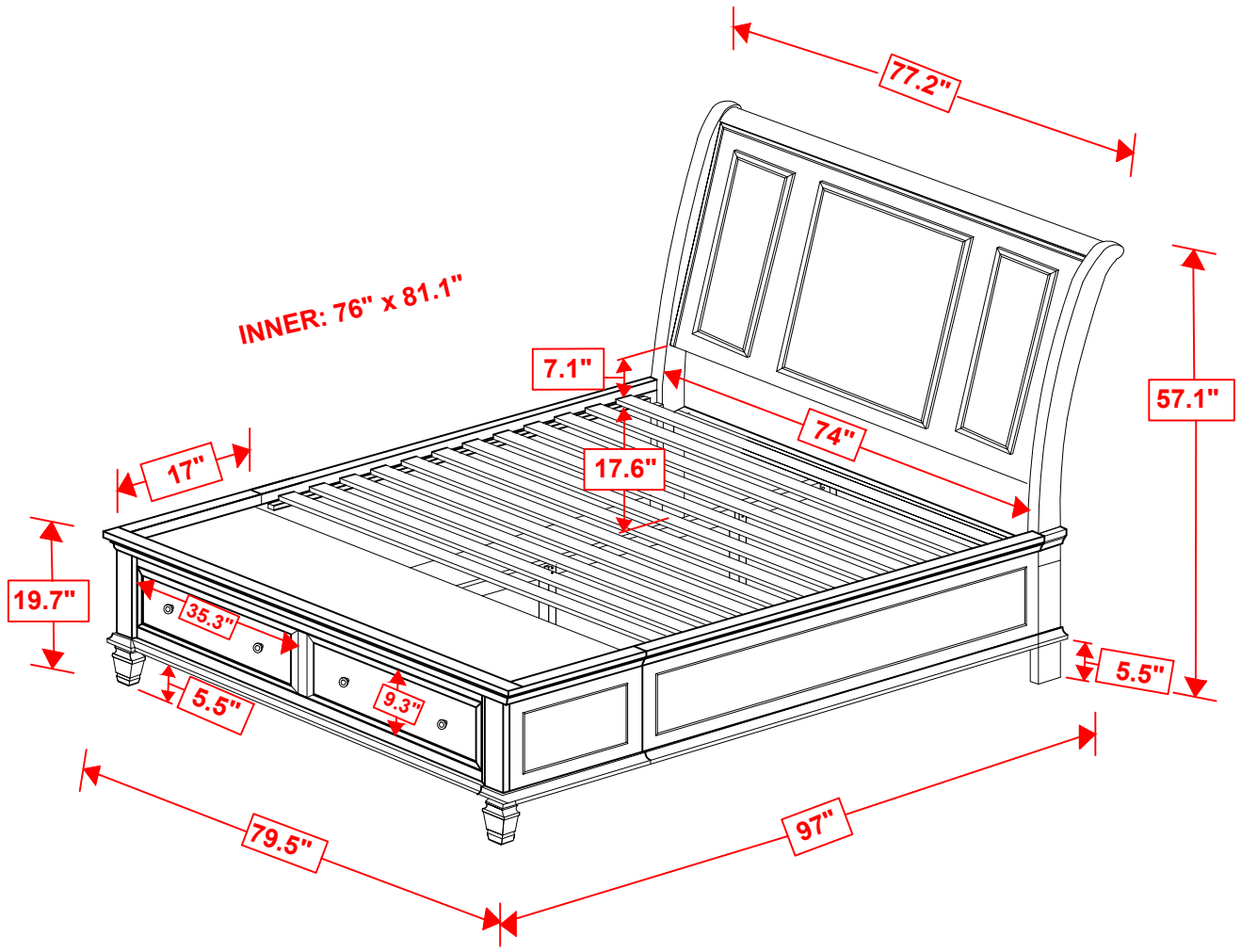

INNER SIZE OF DRAWER A : 5.6" x 14.8" x 33.2"

NOTE : DIMENSION TOLERANCE ± 5%

COASTERFURNITURE.COM