

# **COASTER**® 202411Q (B1 & B2)

*FINE FURNITURE*

**QUEEN BED**

---

## **ASSEMBLY INSTRUCTIONS COASTER FINE FURNITURE**



**[www.coastercompany.com](http://www.coastercompany.com)**

**ASSEMBLY TIPS:**

1. Remove hardware from box and sort by size.
2. Please check to see that all hardware and parts are present prior to start of assembly.
3. Please follow attached instructions in the same sequence as numbered to assure fast & easy assembly.



**Warning!**

1. Don't attempt to repair or modify parts that are broken or defective. Please contact the store immediately.
2. This product is for home use only and not intended for commercial establishments.

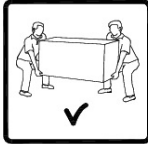

**ASSEMBLY TIME**

**20 MINUTES**

**PARTS IDENTIFICATION**

**B1 (BOX 1)**

	PART NAME	FIGURE	QTY
AN	HEADBOARD PANEL		1PC
BN	LEFT HEADBOARD LEG		1PC
CN	RIGHT HEADBOARD LEG		1PC
DN	FOOTBOARD PANEL		1PC
EN	LEFT FOOTBOARD LEG		1PC
FN	RIGHT FOOTBOARD LEG		1PC

**B2 (BOX 2)**

GN	BED RAIL		2PCS
HN	BED SLAT		4PCS
IN	BED SLAT SUPPORT WITH LEVELER		4PCS
HBN	202411Q (B1) * FROM BOX 1 HEADBOARD COMPLETE		1PC
FBN	202411Q (B1) * FROM BOX 1 FOOTBOARD		1PC

**HARDWARE IDENTIFICATION**

**Z-B1 (BOX 1) - HARDWARE PACK IS LOCATED IN 202411Q (B1)**

	HARDWARE NAME	FIGURE	QTY
1	BOLT (M6 x 35mm - BLK)		12PCS
2	LOCK WASHER (M6 - BLK)		12PCS
3	SMALL FLAT WASHER (M6 x 13mm - BLK)		4PCS
4	BIG FLAT WASHER (M6 x 19mm - BLK)		8PCS

5	ALLEN WRENCH (M4 x 65mm - BLK)		1PC
6	WOOD PLUG		4PCS
7	PAN HEAD SCREW (M4 x 32mm - BLK)		8PCS

**NOTE : PHILLIPS HEAD SCREW DRIVER IS REQUIRED IN THE ASSEMBLY PROCESS; HOWEVER, MANUFACTURER DOES NOT PROVIDE THIS ITEM.**

202411Q (B1) - BOX 1

STEP 1

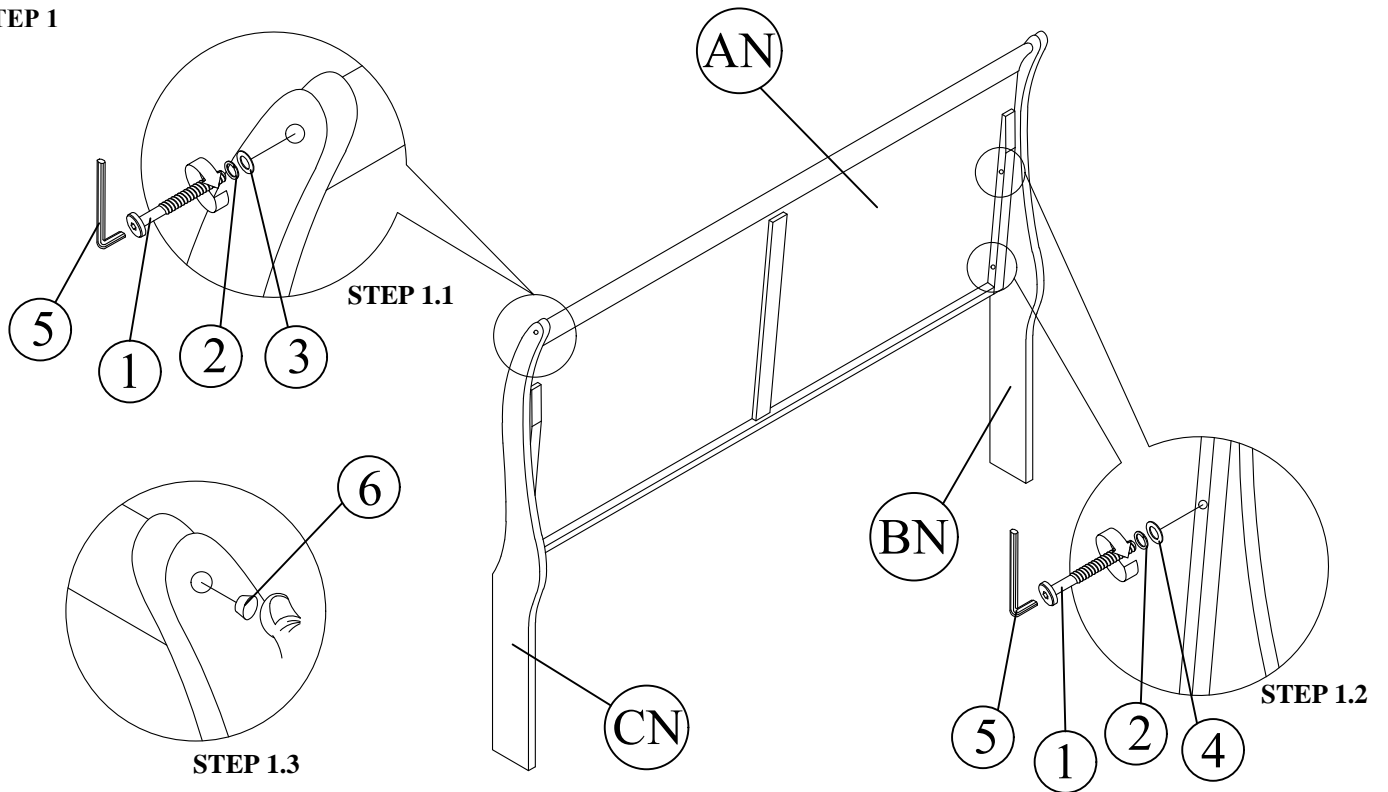

STEP 2

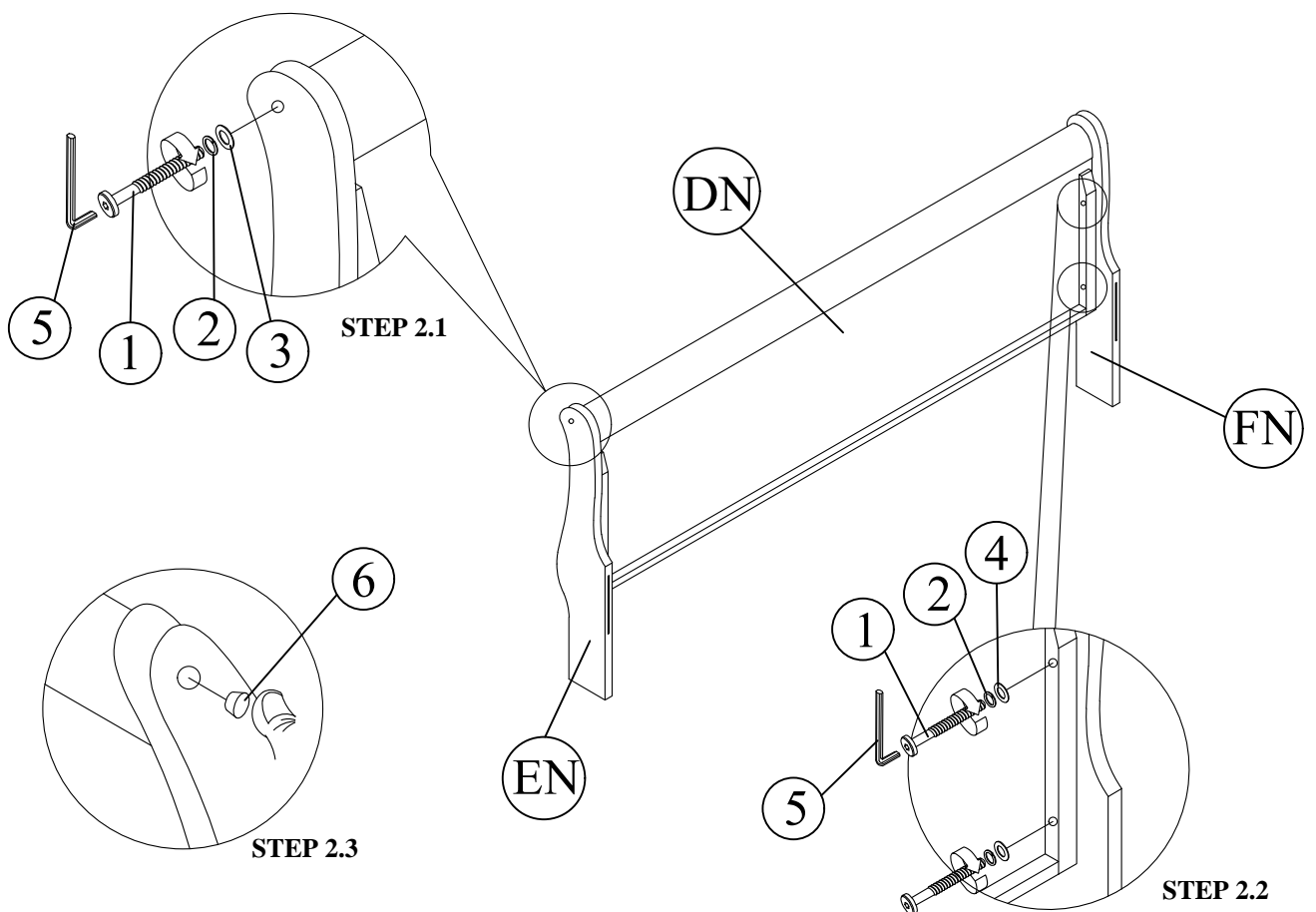

202411Q (B1 & B2) - BOX 1 & BOX 2

STEP 3

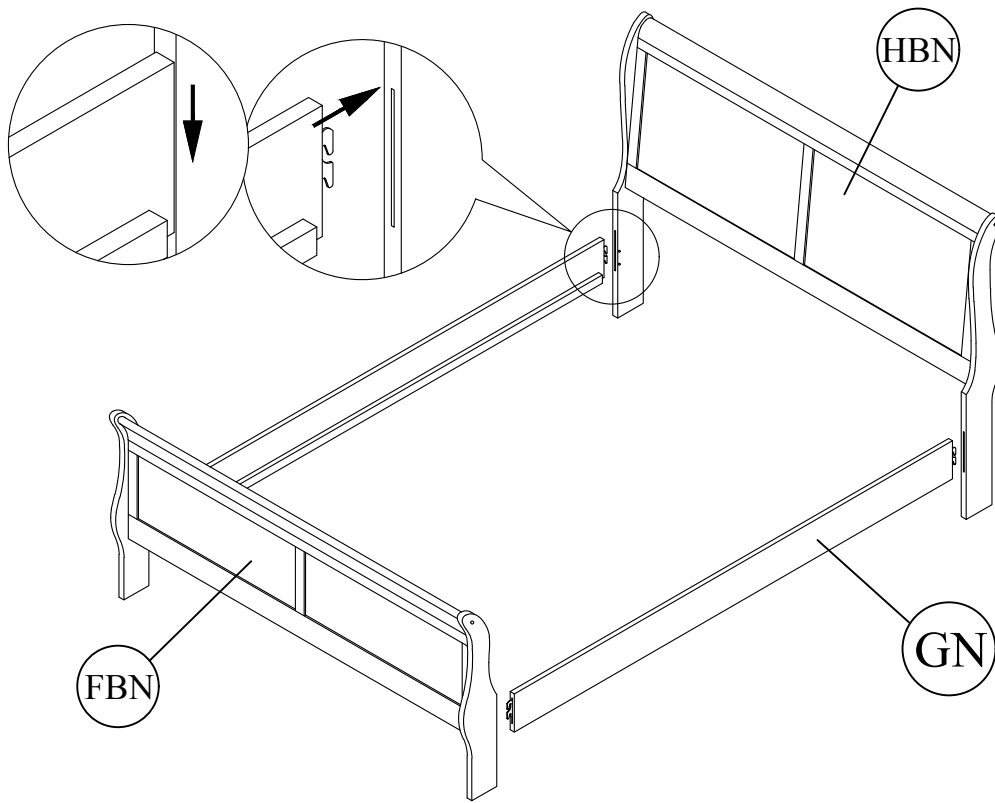

STEP 4

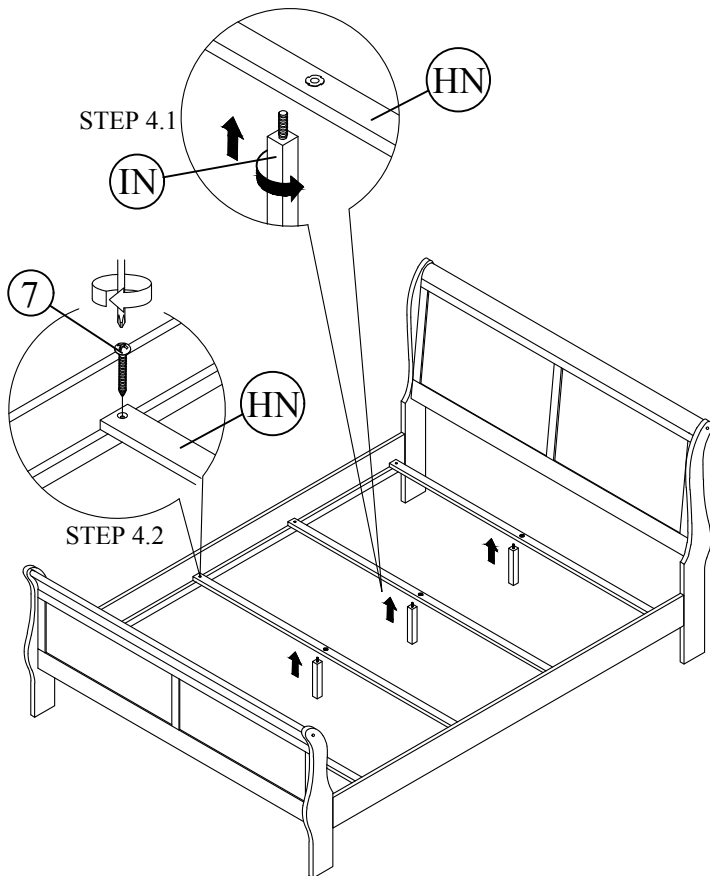

STEP 5  
COMPLETE

