



## ASSEMBLY INSTRUCTIONS COASTER FINE FURNITURE



**600416**

***POWER LIFT RECLINER***

RREVISION 0 : 02/14/2019

RREVISION 1 : 01/07/2020

**PAGE 1 OF 5**

COASTERFURNITURE.COM

ITEM : **600416**



**ASSEMBLY INSTRUCTIONS**

**ASSEMBLY TIPS:**

- 1. Remove hardware from box and sort by size.
- 2. Please check to see that all hardware and parts are present prior to start of assembly.
- 3. Please follow attached instructions in the same sequence as numbered to assure fast & easy assembly.



**Warning!**

- 1. Don't attempt to repair or modify parts that are broken or defective. Please contact the store immediately.
- 2. This product is for home use only and not intended for commercial establishment.



ASSEMBLY TIME PER UNIT:	10 MINUTES
-------------------------	------------

**PARTS IDENTIFICATION**

(A)

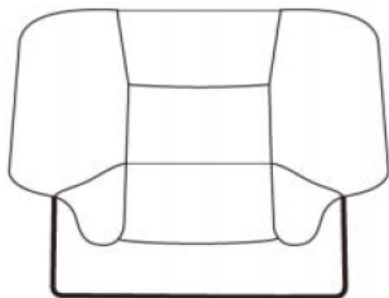

**BACK 1PC**

(B)

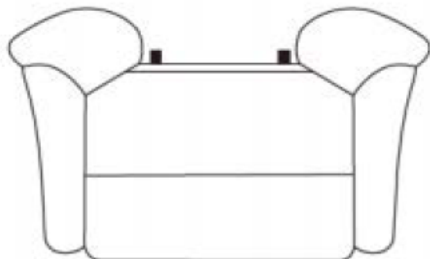





**BASE 1PC**

ITEM : 600416



**ASSEMBLY INSTRUCTIONS**

- |     |   |               |      |
|-----|---|---------------|------|
| (C) |  | POWER ADAPTER | 1PC  |
| (D) |  | POWER CABLE   | 1PC  |
| (E) |  | LINK CABLE    | 1PC  |
| (F) |  | SUPPORT LEG   | 2PCS |

**Z**

**HARDWARE IDENTIFICATION**

1  BOLT 1/4"×38mm 4PCS

2  BUTTERFLY NUT 4PCS

**STEP1**

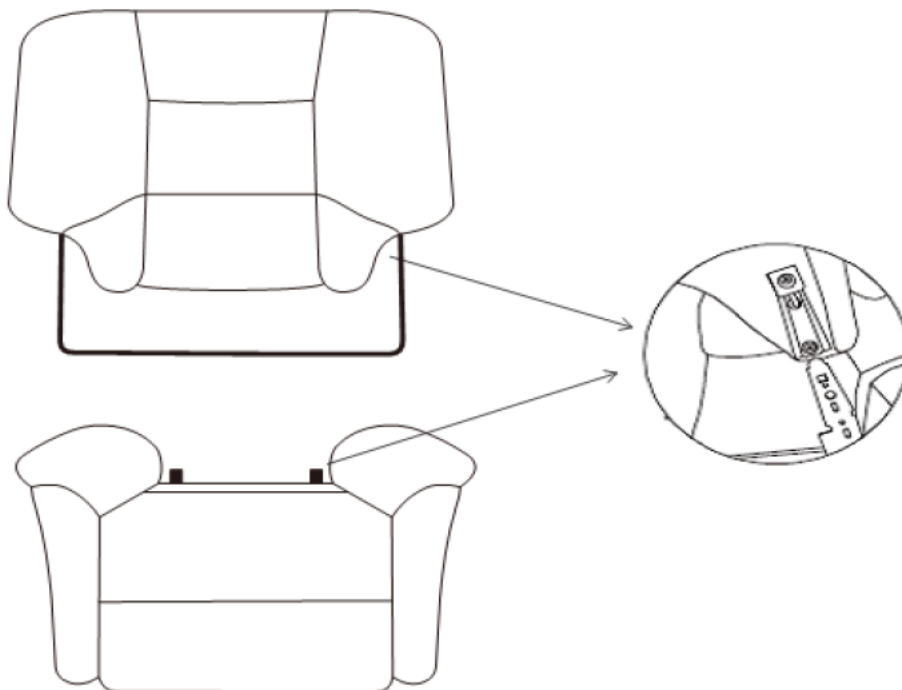

ITEM : 600416



ASSEMBLY INSTRUCTIONS

STEP2

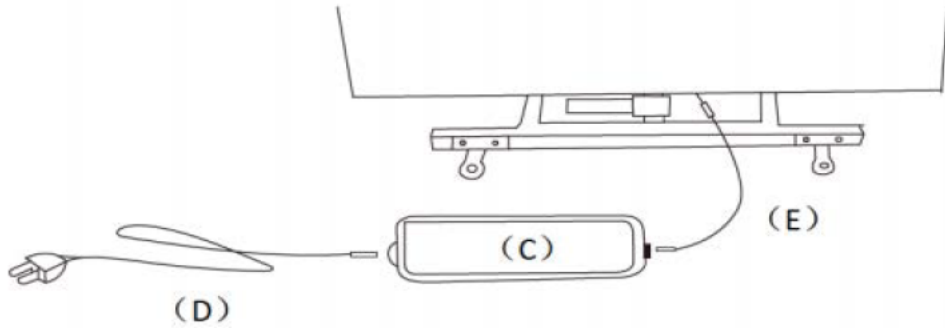

STEP3

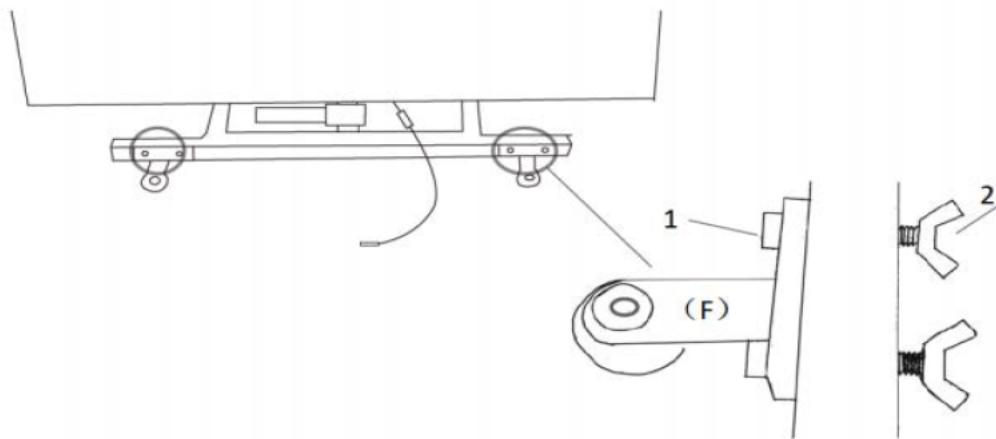

STEP4

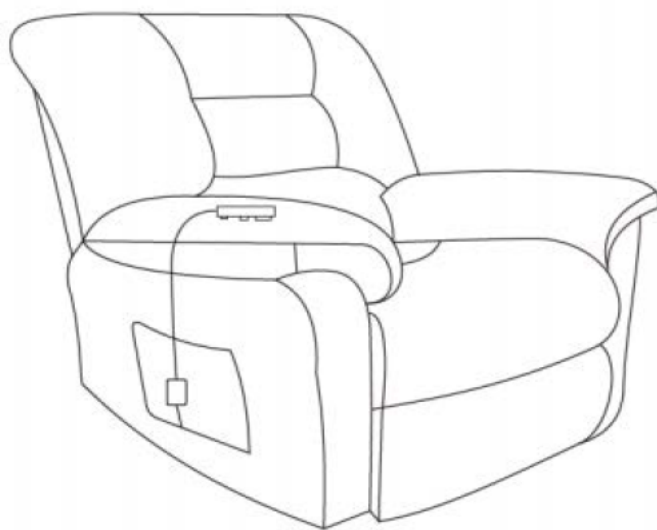

ITEM: 600416



ASSEMBLY INSTRUCTIONS  
STEP 5

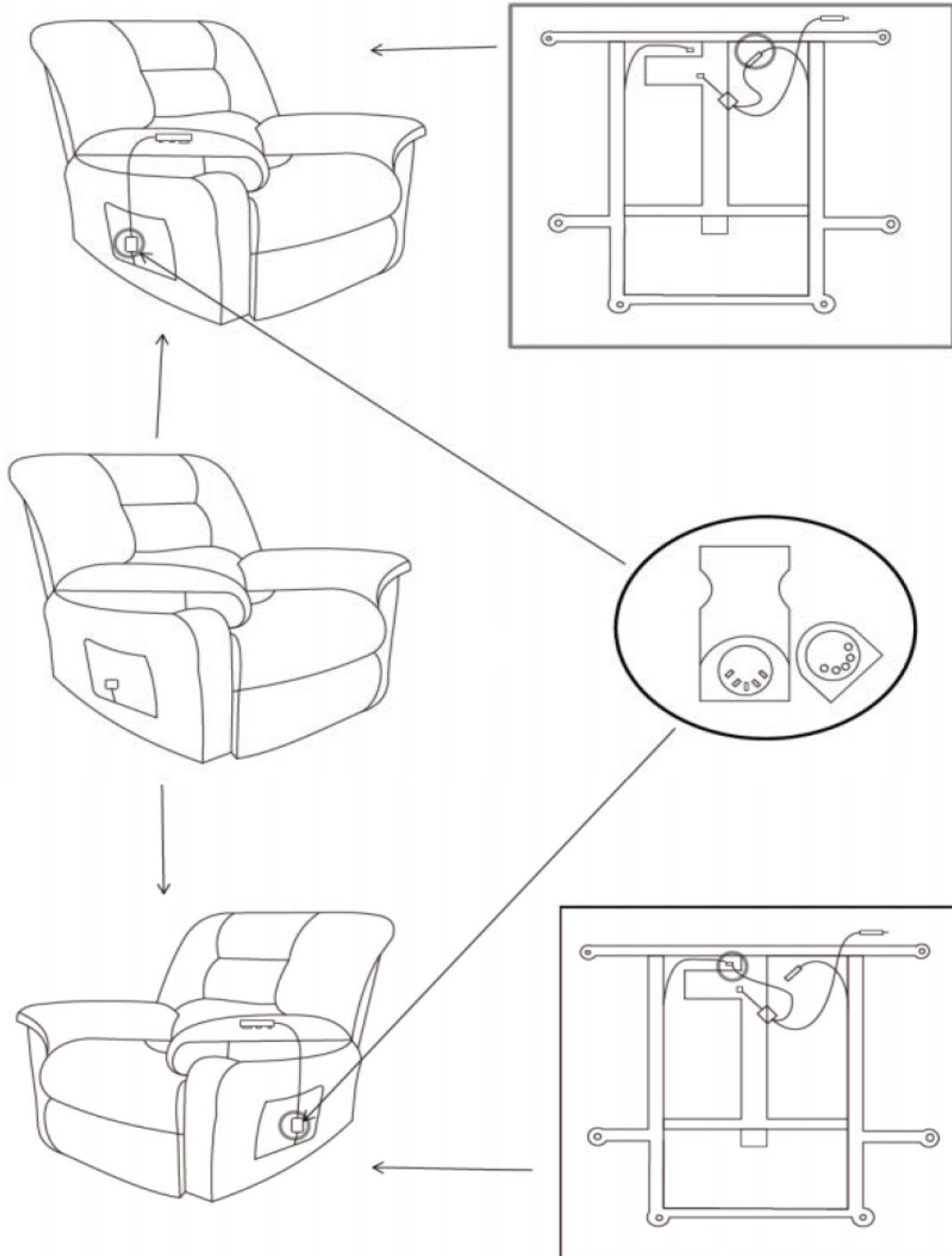



Note : Dimension tolerance  $\pm 5\%$