

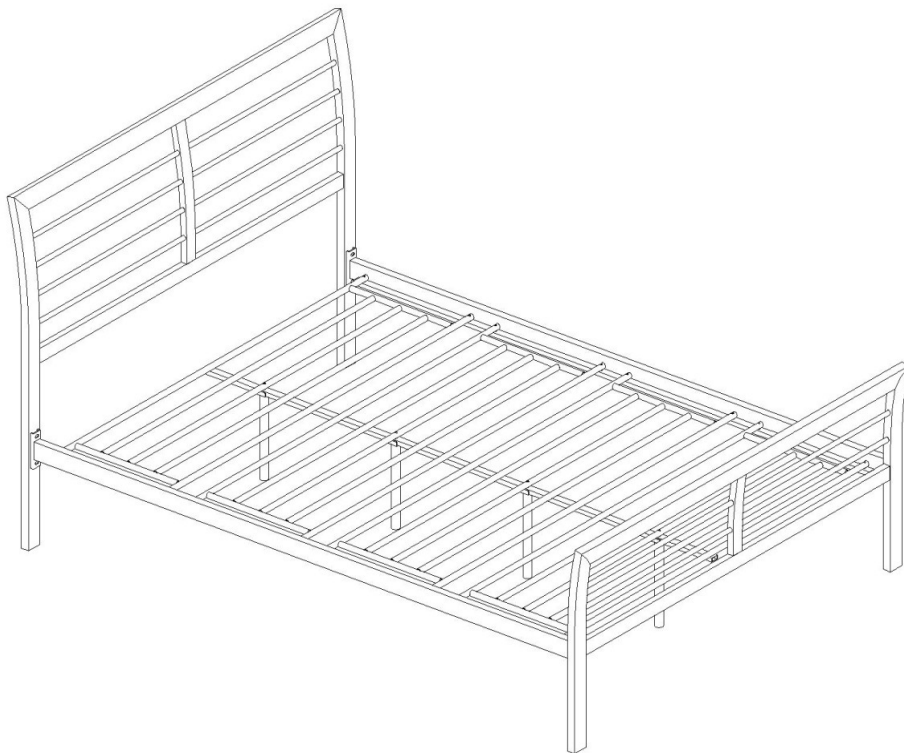

# ASSEMBLY INSTRUCTIONS

## COASTER FINE FURNITURE



*Fine Furniture for every stage of life*

# 300201Q(B1-B2)

## Queen Bed

REVISION 0 : 05/30/2019  
REVISION 1 : 10/21/2019

# ITEM: 300201Q(B1-B2)



## ASSEMBLY INSTRUCTIONS

### ASSEMBLY TIPS:

1. Remove hardware from box and sort by size.
2. Please check to see that all hardware and parts are present prior to start of assembly.
3. Please follow attached instructions in the same sequence as numbered to assure fast & easy assembly.

### WARNING!

1. Don't attempt to repair or modify parts that are broken or defective. Please contact the store immediately.
2. This product is for home use only and not intended for commercial establishments.





**ASSEMBLY TIME**



**15 MINUTES**

## PARTS IDENTIFICATION

### B1 ( BOX 1 )







A	HEADBOARD		1PC	C	PLATFORM		4PCS
B	FOOTBOARD		1PC				

### B2 ( BOX 2 )

D	SIDE RAIL		2PCS	F	SUPPORT LEG		4PCS
E	PLATFORM SUPPORT		1PC				

## HARDWARE IDENTIFICATION

### HARDWARE PACK IS LOCATED IN 300201QB1

1	BOLT M6X25mm		8PCS	5	NUT M6		16PCS
2	BOLT M6X38mm		16PCS	6	ALLEN KEY 4mm		1PC
3	BOLT M6X45mm		4PCS	7	WRENCH 10mm		1PC
4	WASHER 6.5mm		24PCS				

### NOTE:

Phillips head screw driver is required in the assembly process; however, manufacturer does not provide this item.

ITEM: **300201Q(B1-B2)**



**ASSEMBLY INSTRUCTIONS**

**STEP 1**

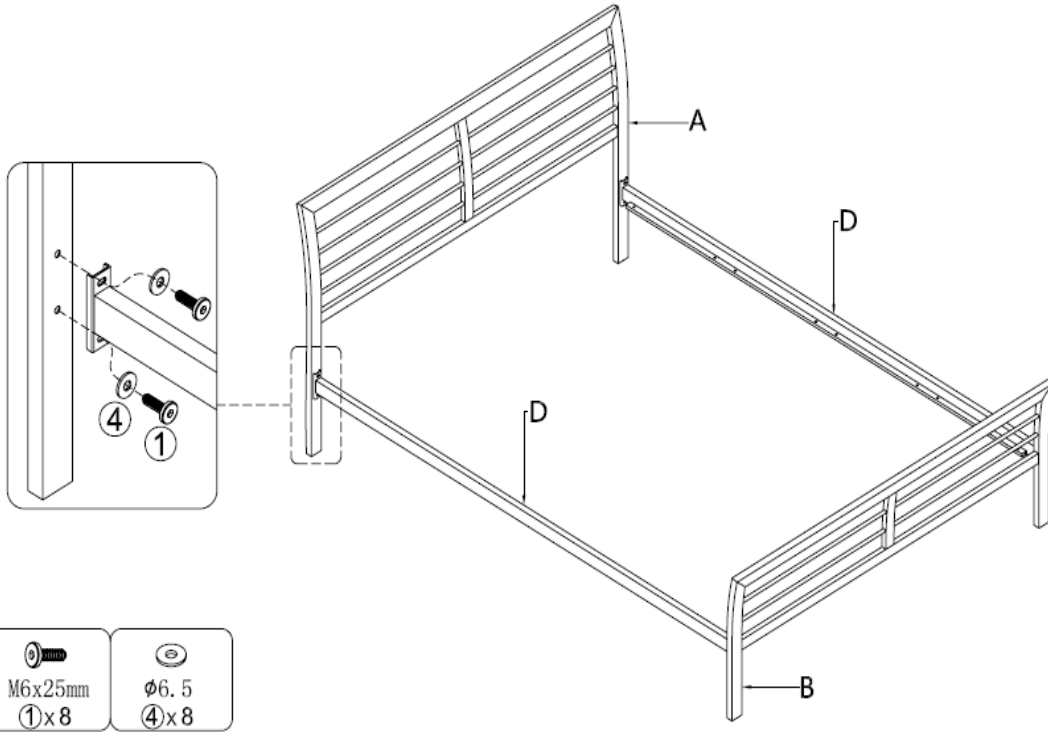

**STEP 2**

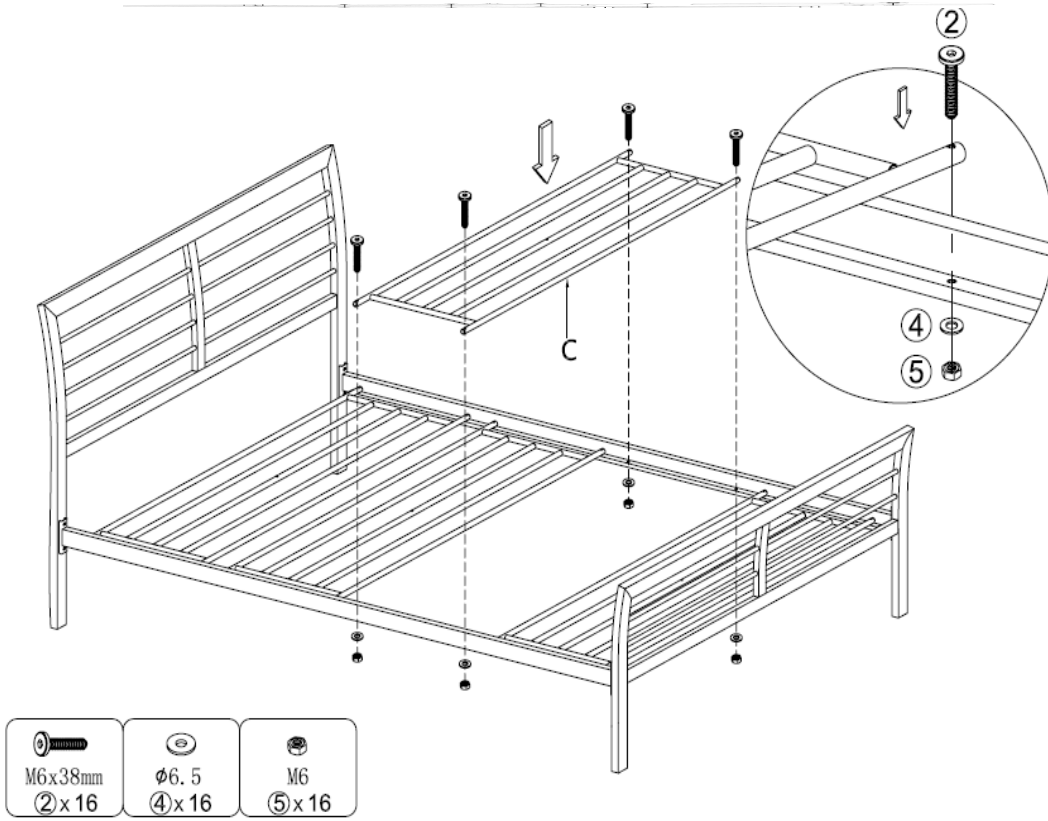

ITEM: **300201Q(B1-B2)**



**ASSEMBLY INSTRUCTIONS**  
**STEP 3**

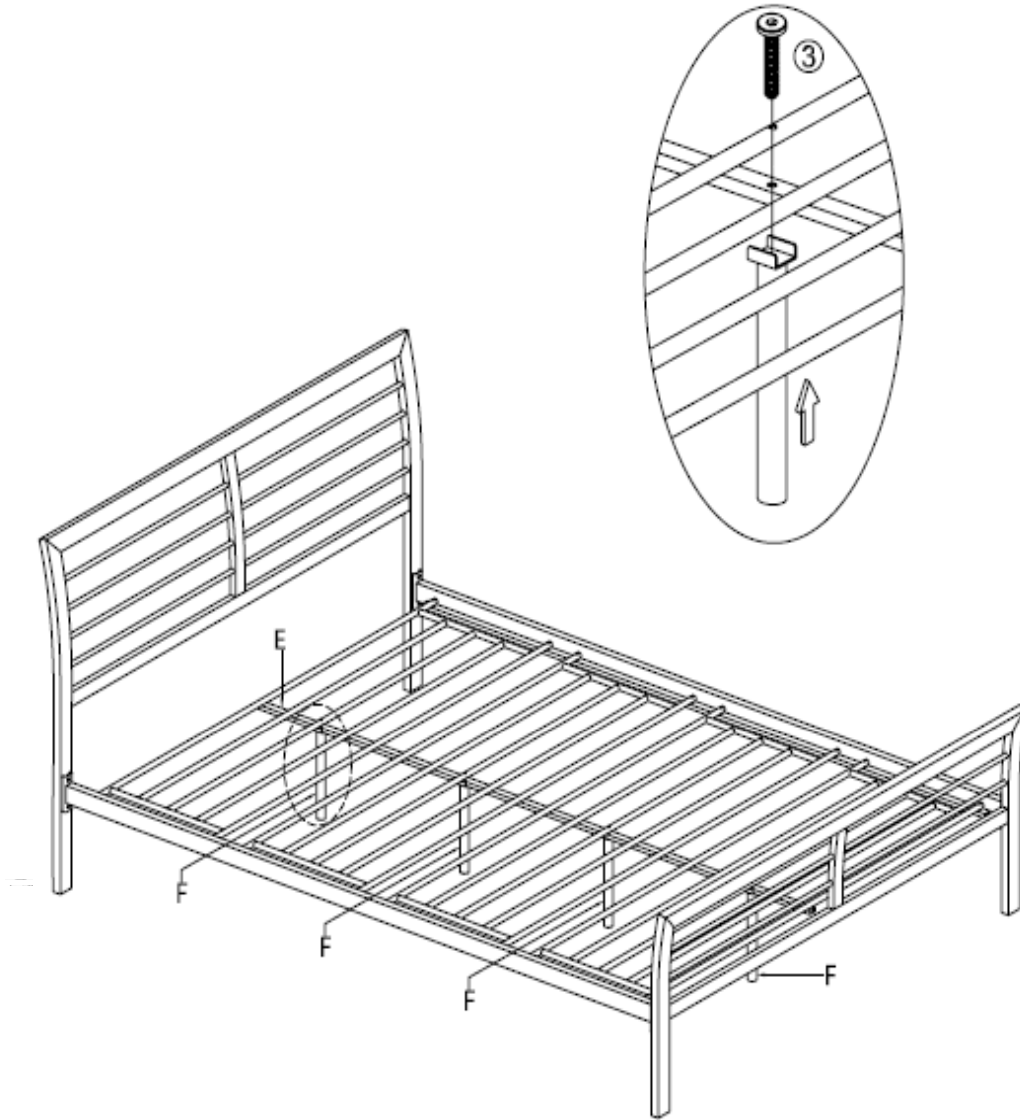

ITEM: **300201Q(B1-B2)**

PRODUCT DIMENSION:

