

SERVER CART

**ASSEMBLY INSTRUCTION
COASTER FINE FURNITURE**



www.coastercompany.com

ASSEMBLY INSTRUCTION

ASSEMBLY TIPS:

- 1.Remove hardware from box and sort by size.
- 2.Please check to see that all hardware and parts are present prior to start of assembly.
- 3.Please follow attached instructions in the same sequence as numbered to assure fast & easy assembly.









Warning!!

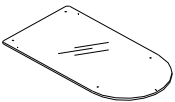

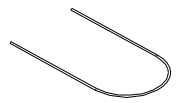
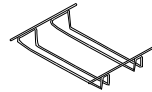
- 1.Don't attempt to repair or modify parts that are broken or defective. Please contact the store immediately.
- 2.This product is for home use only and not intended for commercial establishment.

ASSEMBLY TIME PER UNIT: 45 MINUTES

PARTS IDENTIFICATION

<p>A</p> <p>HAND RAIL</p>  <p>1PC</p>	<p>B</p> <p>GLASS</p>  <p>2PCS</p>
<p>CL</p> <p>LEFT SIDE FRAME</p>  <p>1PC</p>	<p>CR</p> <p>RIGHT SIDE FRAME</p>  <p>1PC</p>
<p>D</p> <p>U FRAME</p>  <p>2PCS</p>	<p>E</p> <p>GLASS HOLDER</p>  <p>1PC</p>
<p>F</p> <p>BOTTLE HOLDER</p>  <p>1PC</p>	<p>G</p> <p>CASTER</p>  <p>2PCS</p>
<p>H</p> <p>CASTER WITH LOCK</p>  <p>2PCS</p>	

HARDWARE PACKAGE

Z	DESCRIPTION	FIGURE	Q'TY
1	PLASTIC SPACER (φ 12x30mm)		6PCS
2	BOLT CAP (φ 35mm)		2PCS
3	LONG CROSS HEAD BOLT (3/16" x38mm)		6PCS

4	SHORT BOLT (1/4"x12mm)		2PCS
5	LARGE BOLT (1/4"x38mm)		2PCS
6	SMALL WASHER (φ 12mm)		6PCS
7	LARGE WASHER (φ 25mm)		4PCS
8	SMALL PLASTIC WASHER (φ 23mm)		12PCS
9	CAP (φ 25mm)		2PCS
10	SHORT CROSS HEAD BOLT (3/16"x12mm)		2PCS
11	LARGE PLASTIC WASHER (φ 25x5mm)		2PCS
12	ALLEN KEY (4mm)		1PC
13	HEXAGONAL KEY (8mm)		1PC

STEP 1

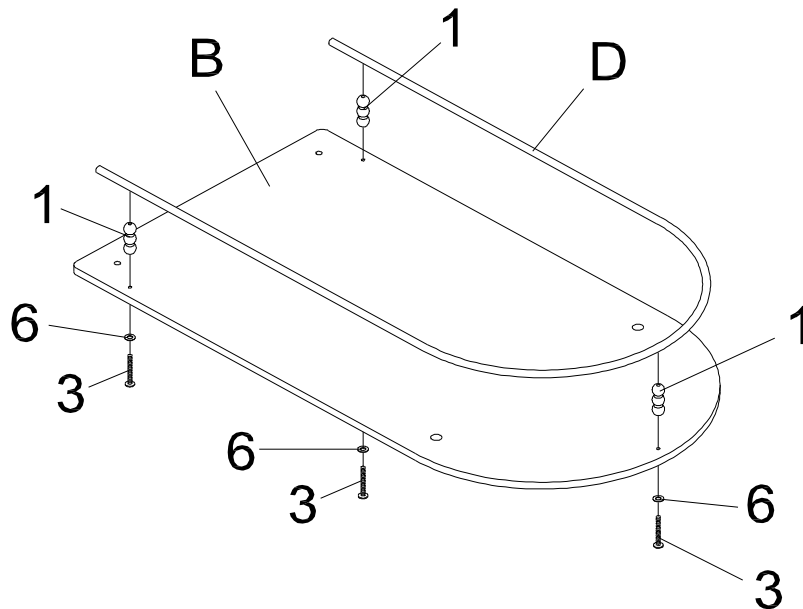

STEP 2

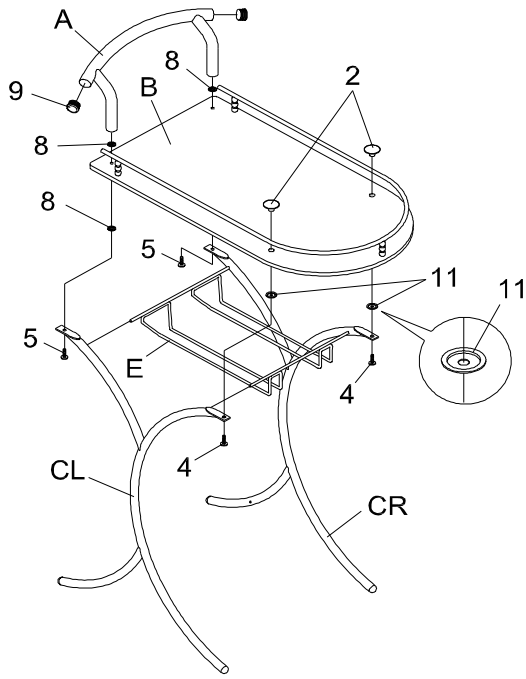

STEP 3

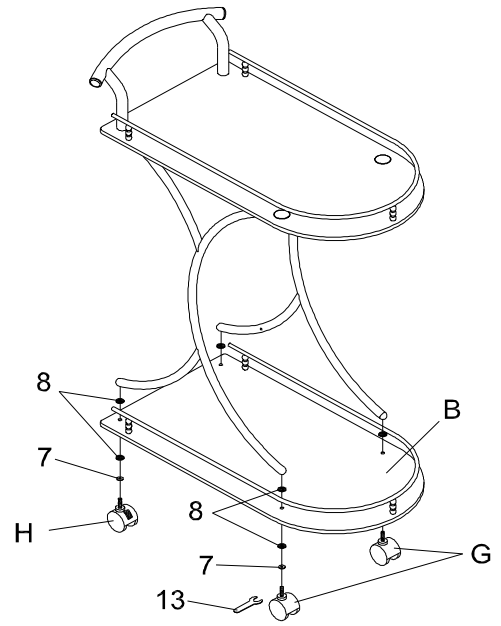

STEP 4

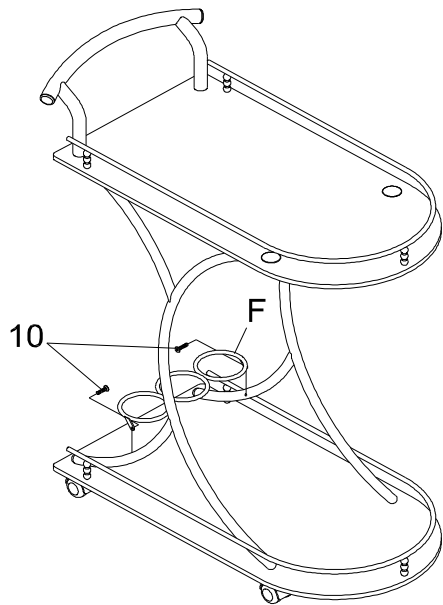

FINISH

