ASSEMBLY INSTRUCTIONS



ASSEMBLY INSTRUCTION

ASSEMBLY TIPS:

- 1.Remove hardware from box and sort by size.
- 2.Please check to see that all hardware and parts are present prior to start of assembly.
- 3.Please follow attached instructions in the same sequence as numbered to assure fast & easy assembly.



Warning!!

- 1.Don't attempt to repair or modify parts that are broken or defective. Please contact the store immediately.
- 2.This product is for home use only and not intended for commercial establishment.

ASSEMBLY TIME PER UNIT: 30 MINUTES

PARTS IDENTIFICATION

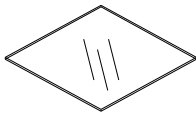
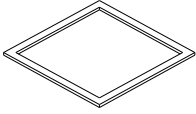
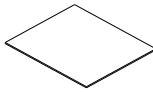
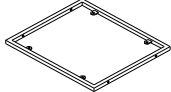
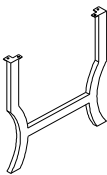
<p>A</p> <p>GLASS</p>  <p>1PC</p>	<p>B</p> <p>TOP FRAME</p>  <p>1PC</p>
<p>C The mirror part provided in this package is not a tempered mirror. Please handle with care. Mirror part may explode.</p> <p>MIRROR</p>  <p>1PC</p>	<p>D</p> <p>BOTTOM FRAME</p>  <p>1PC</p>
<p>E</p> <p>SIDE FRAME</p>  <p>2PCS</p>	

HARDWARE PACKAGE

Z	DESCRIPTION	FIGURE	Q'TY
1	SHORT BOLT (1/4"x12mm)		8PCS
2	LONG BOLT (1/4"x28mm)		4PCS
3	SUCTION CUP (φ 12mm)		4PCS
4	ADHESIVE (φ 15x1mm)		4PCS

5	LEVELER (1/4"x12mm)		4PCS
6	ALLEN WRENCH (4mm)		1PC

STEP 1

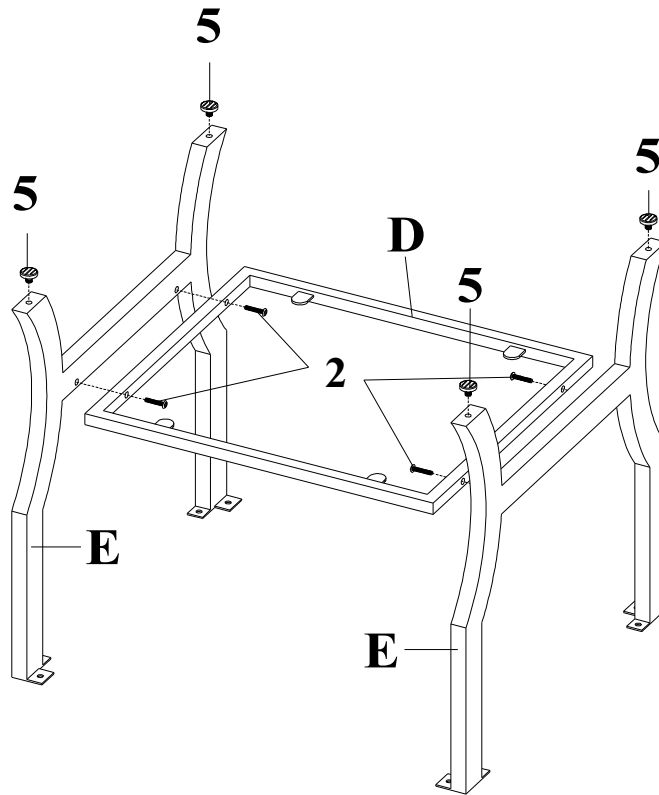

STEP 2

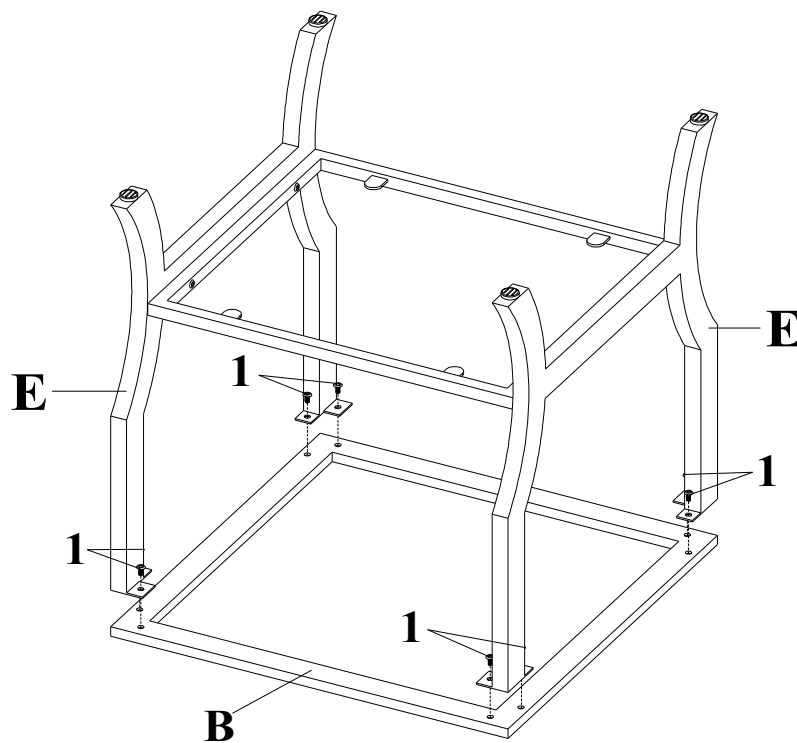

STEP 3

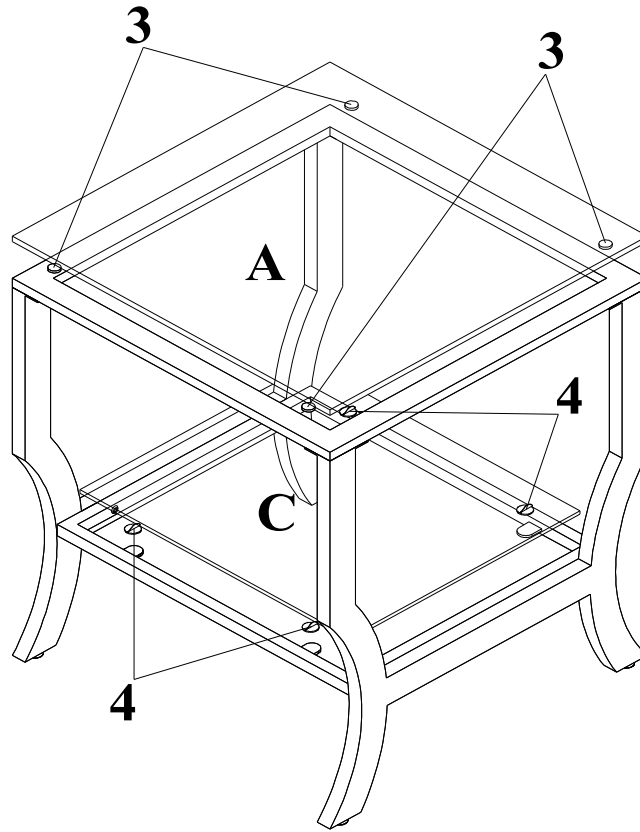

FINISH

