

ASSEMBLY INSTRUCTIONS
COASTER FINE FURNITURE



Fine Furniture for every stage of life

100654
BAR TABLE

REVISION 0 : 08/22/2017
REVISION 1 : 09/09/2019

ITEM: 100654



ASSEMBLY INSTRUCTIONS

ASSEMBLY TIPS:

1. Remove hardware from box and sort by size.
2. Please check to see that all hardware and parts are present prior to start of assembly.
3. Please follow attached instructions in the same sequence as numbered to assure fast & easy assembly.





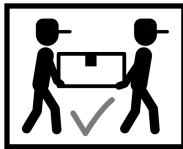

WARNING!

1. Don't attempt to repair or modify parts that are broken or defective. Please contact the store immediately.
2. This product is for home use only and not intended for commercial establishments.

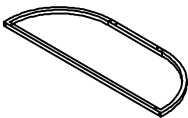
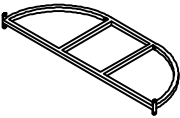

ASSEMBLY TIME 60 MINUTES

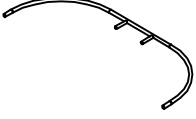
PARTS IDENTIFICATION

A	TOP FRAME		1PC
B	MIDDLE FRAME		1PC
C	BOTTOM REST BAR		1PC
D	FOOT REST BAR		1PC
E	LEFT CROSS BAR		1PC
F	RIGHT CROSS BAR		1PC

ITEM:100654

ASSEMBLY INSTRUCTIONS

PARTS IDENTIFICATION



G FOOT REST SIDE PLATE 2PCS



H FRONT FRAME 1PC



I TOP GLASS 1PC

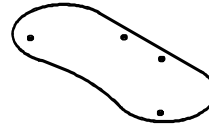

J SHELF GLASS 1PC

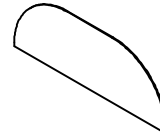

K FRONT GLASS 1PC



L SIDE ACRYLIC 2PCS

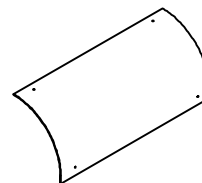

M BOTTOM LEG SUPPORT 4PCS

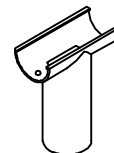

ITEM:100654

ASSEMBLY INSTRUCTIONS



PARTS IDENTIFICATION

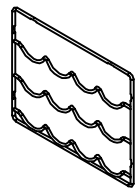
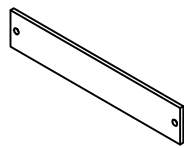
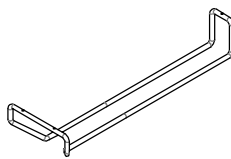

















N	BOTTLE RACK		2PCS
O	BOTTLE RACK BOTTOM BAR		2PCS
P	GLASS HOLDER		3PCS

ITEM:100654

ASSEMBLY INSTRUCTIONS



HARDWARE IDENTIFICATION

1	BOLT (ϕ 26 x 12mm SR)		10PCS	10	ALLEN KEY (4mm)		1PC
2	SMALL ALLEN BOLT (1/4" x 12mm SR)		14PCS	11	PLASTIC WASHER (ϕ 25mm)		2PCS
3	ALLEN BOLT (1/4" x 25mm SR)		6PCS	12	SUCTION CUP (ϕ 12mm)		4PCS
4	MEDIUM ALLEN BOLT (1/4" x 32mm BLK)		10PCS	13	SMALL NUT (3/16" SR)		4PCS
5	NUT (1/4" SR)		8PCS	14	WASHER (ϕ 25mm SR)		2PCS
6	FLOOR LEVELER (ϕ 30 x 20mm BLK)		4PCS	15	SMALL BOLT (3/16" x 10mm SR)		17PCS
7	ROUND CAP (ϕ 25 BLK)		4PCS	16	LARGE ALLEN BOLT (1/4" x 2" SR)		2PCS
8	CAP (18 x 18mm BLK)		4PCS	17	LARGE HEXAGONAL KEY (3/16")		1PC
9	SMALL WASHER (ϕ 18mm SR)		8PCS	18	HEXAGONAL KEY (3/16")		1PC

ITEM: 100654 ASSEMBLY INSTRUCTIONS



STEP 1 Do not tighten until each step is completed or instructed.

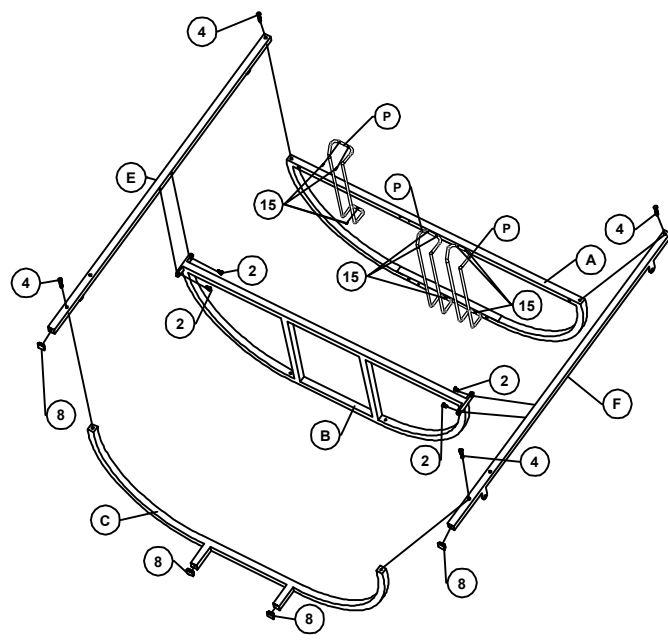

STEP 2

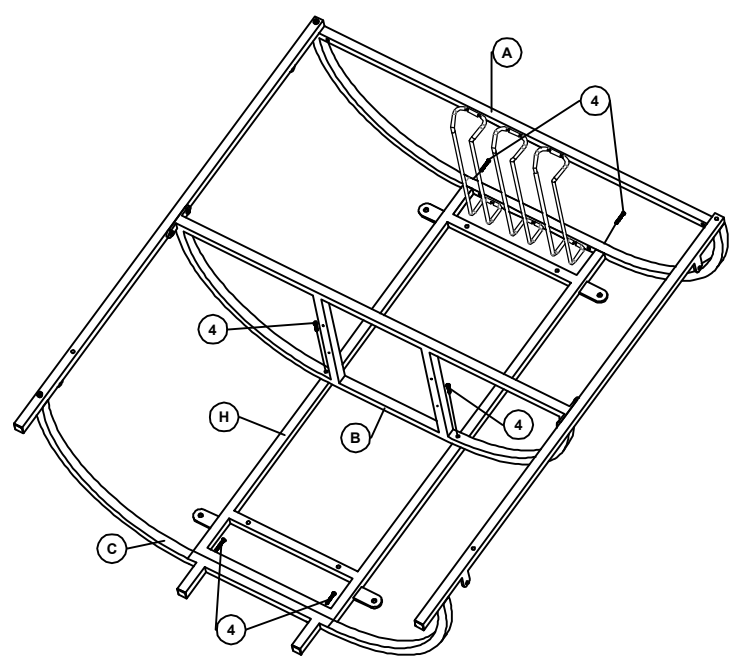

ITEM: 100654
ASSEMBLY INSTRUCTIONS
STEP 3

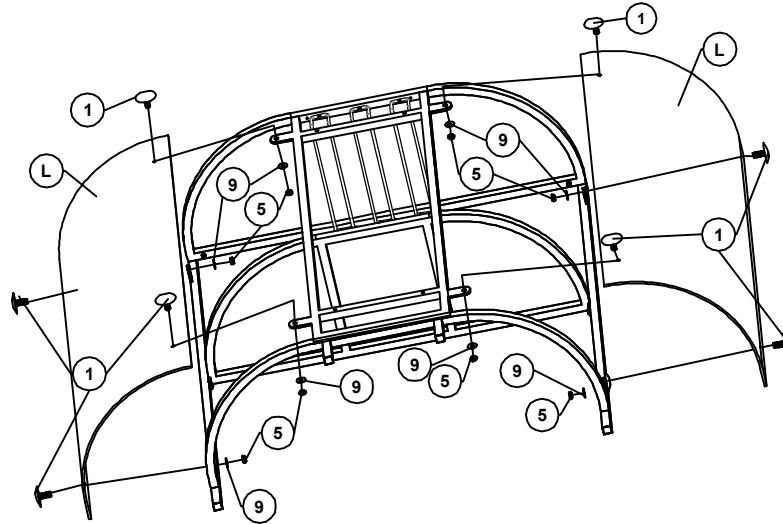

STEP 4

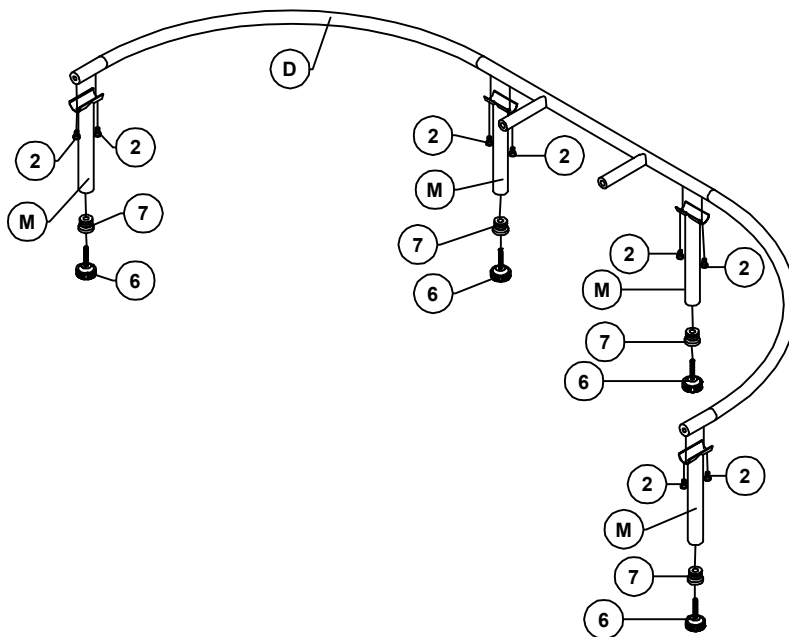

ITEM: 100654
ASSEMBLY INSTRUCTIONS
STEP 5

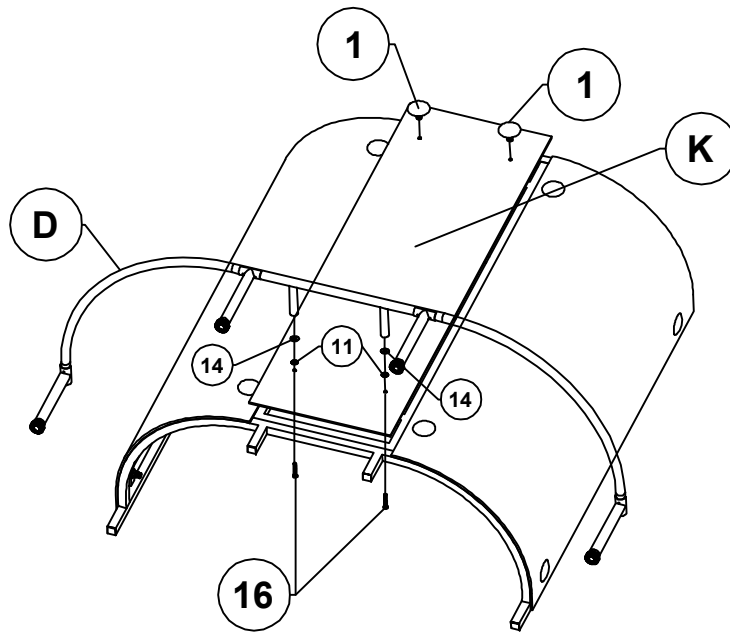

STEP 6

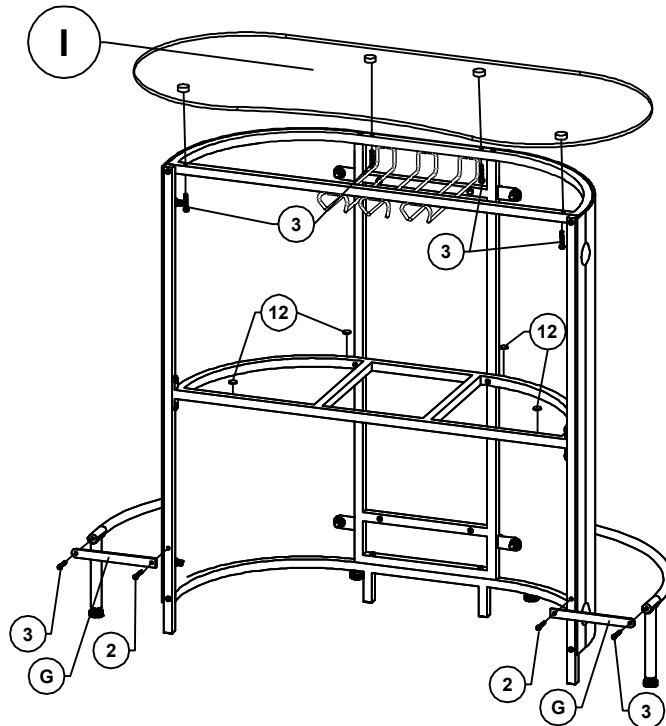

ITEM: 100654
ASSEMBLY INSTRUCTIONS
STEP 7

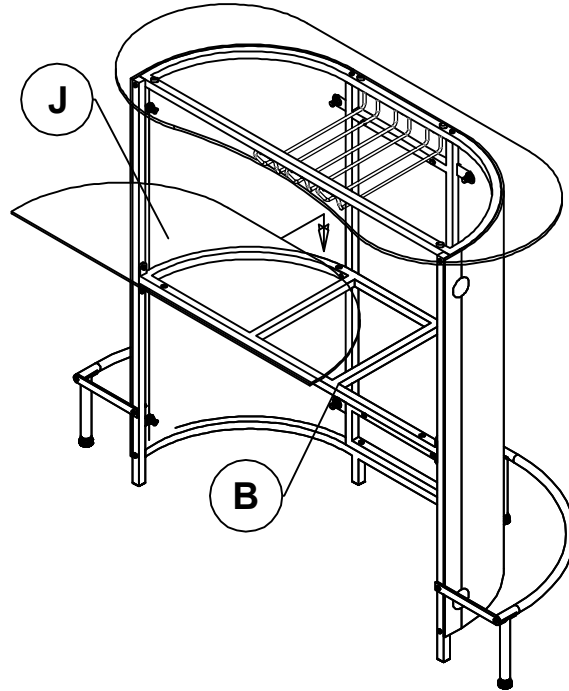

STEP 8

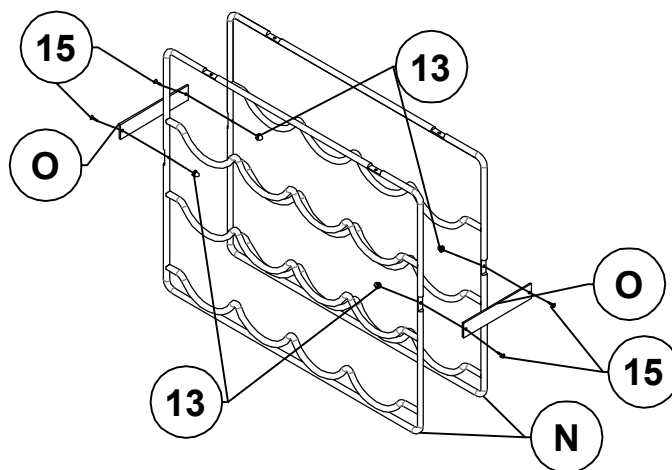

ITEM: 100654
ASSEMBLY INSTRUCTIONS
STEP 9

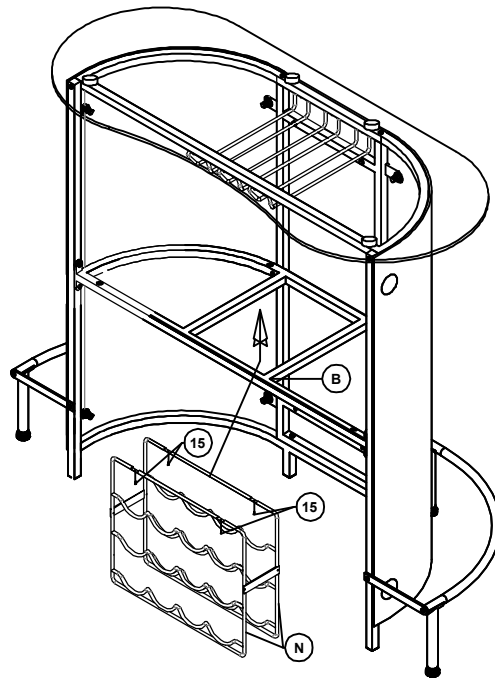

STEP 10
COMPLETE

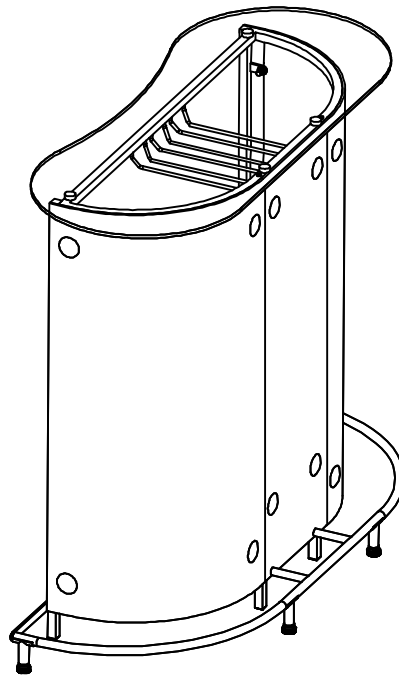

How to clean Acrylic product:
Using a dry soft microfiber cloth, lightly brush off any dust.
For additional care, dampen the cloth with warm water.
For deepest cleaning, use an Acrylic cleaner.

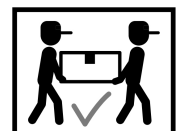

ITEM: 100654 ASSEMBLY INSTRUCTIONS

Product Size : 1226 X 510 X 1100 H (MM)

Product Size : 48 $\frac{1}{4}$ " X 20" X 43 $\frac{1}{4}$ "

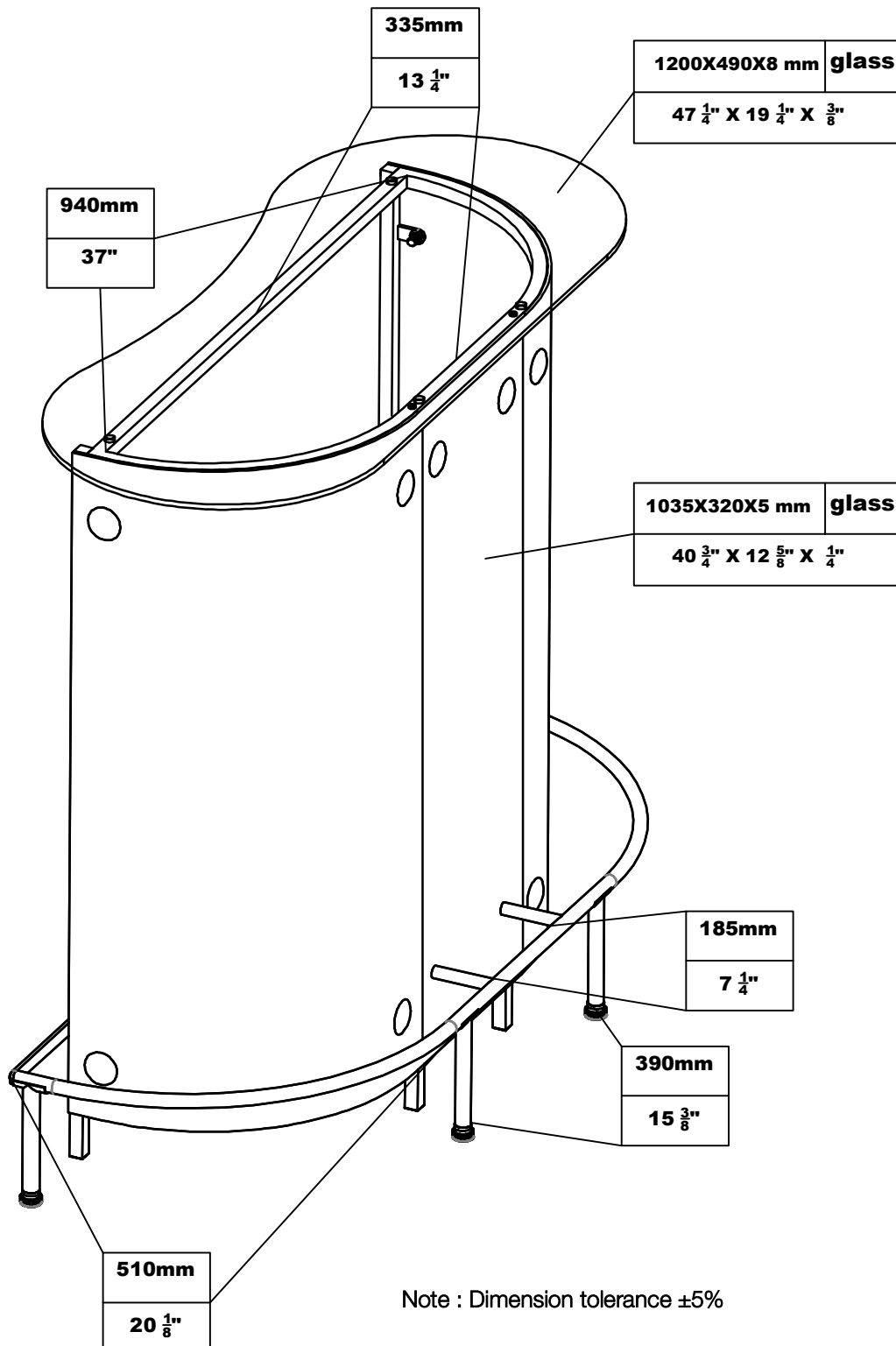

ITEM: 100654 ASSEMBLY INSTRUCTIONS

