

*ASSEMBLY INSTRUCTIONS*  
*COASTER FINE FURNITURE*



*Fine Furniture for every stage of life*

101065  
**BAR TABLE**

REVISION 0 : 11/13/2017  
REVISION 1 : 08/07/2019

ITEM:101065



# ASSEMBLY INSTRUCTIONS

## ASSEMBLY TIPS:

1. Remove hardware from box and sort by size.
2. Please check to see that all hardware and parts are present prior to start of assembly.
3. Please follow attached instructions in the same sequence as numbered to assure fast & easy assembly.



### WARNING!

1. Don't attempt to repair or modify parts that are broken or defective. Please contact the store immediately.
2. This product is for home use only and not intended for commercial establishments.

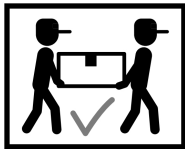

ASSEMBLY TIME 60 MINUTES

## PARTS IDENTIFICATION







A	RIGHT FRONT		1PC
B	LEFT FRONT		1PC
C	BOTTOM CROSSBAR		1PC
D	HANGER BRACKET		3PCS
E	SHELF WOOD CROSSBAR		3PCS
F	LEG SUPPORT BAR		3PCS

ITEM:101065

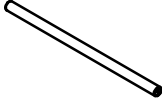
# ASSEMBLY INSTRUCTIONS

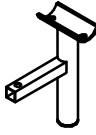
## PARTS IDENTIFICATION

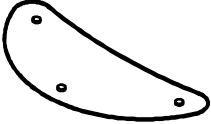

G	LARGE CROSSBAR		2PCS
H	SHELF CROSSBAR		2PCS
I	CONNECTION PICEC		1PC
J	BOTTOM CENTER SUPPORT		1PC
K	BOTTOM SUPPORT BAR		2PCS
L	TOP GLASS		1PC
M	SHELF GLASS		1PC

ITEM:101065

# ASSEMBLY INSTRUCTIONS



## PARTS IDENTIFICATION











N	BOTTOM WOOD		1PC
O	TOP WOOD		1PC
P	METAL		2PCS
Q	BOTTOM WOOD CENTER SUPPORT		1PC

ITEM:101065

# ASSEMBLY INSTRUCTIONS

## HARDWARE IDENTIFICATION



1	LARGE ALLEN BOLT (1/4"x35mm)		5PCS
2	MEDIUM ALLEN BOLT (1/4"x25mm)		5PCS
3	SMALL ALLEN BOLT (1/4"x13mm)		25PCS
4	BOLT (3/16"x12mm)		2PCS
5	LARGE BOLT (10x33mm)		7PCS
6	SCREW (4x12mm)		9PCS
7	GLASS BOLT (5/16")		1PC
8	ALLEN KEY (4mm)		1PC
9	PLASTIC ( $\phi$ 25mm)		4PCS
10	FLOOR LEVELER (5/16"x25mm)		3PCS
11	HEXAGONAL KEY (1/4")		1PC

# ITEM: 101065 ASSEMBLY INSTRUCTIONS



**STEP 1** Do not tighten until each step is completed or instructed.

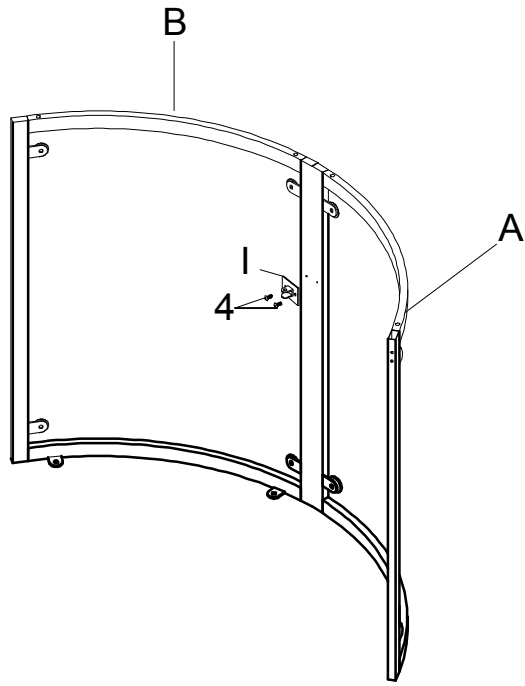

**STEP 2** Put bottom side up to assemble

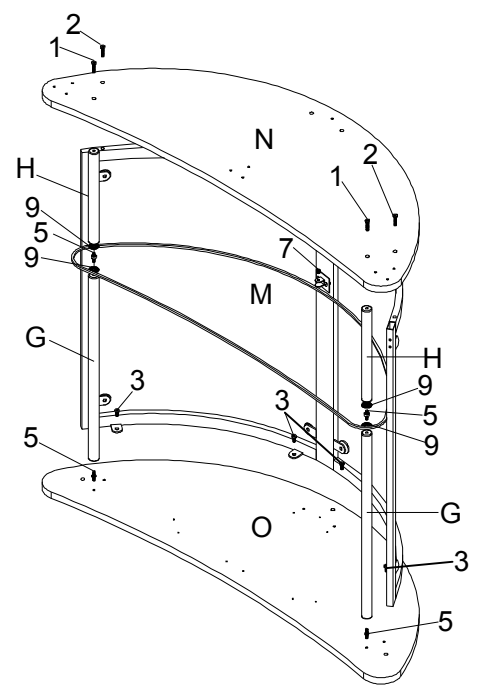

ITEM: 101065  
ASSEMBLY INSTRUCTIONS



STEP 3

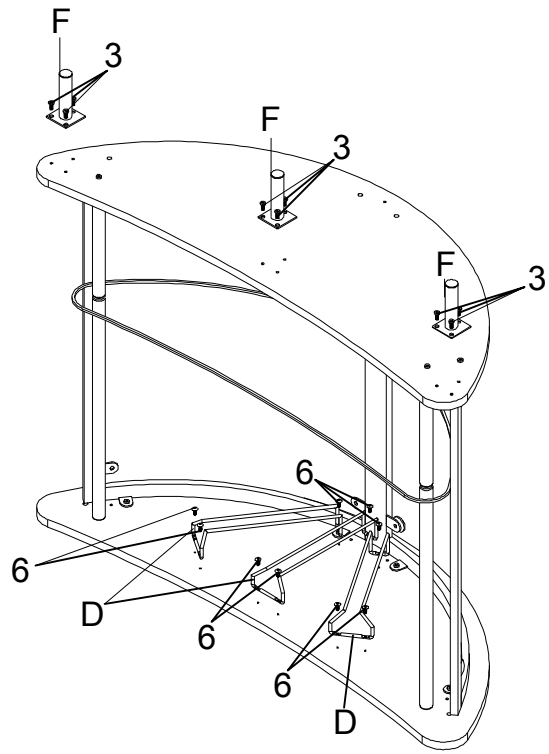

STEP 4

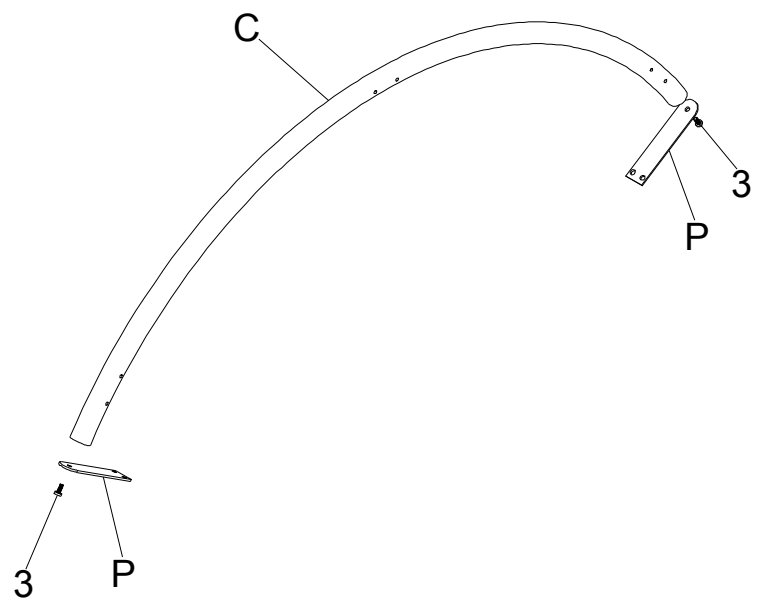

ITEM: 101065  
ASSEMBLY INSTRUCTIONS  
STEP 5

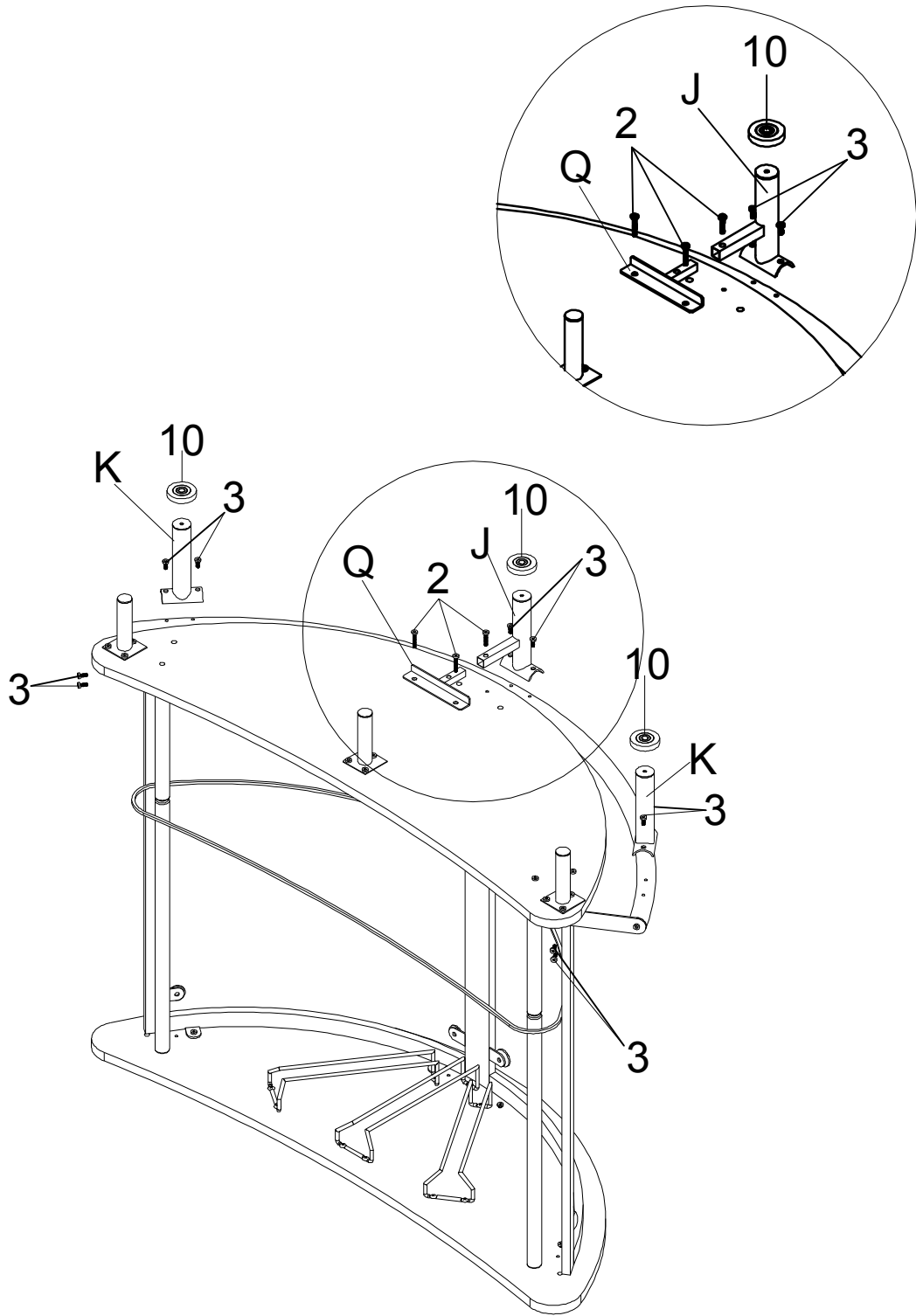



ITEM: 101065  
ASSEMBLY INSTRUCTIONS  
STEP 6

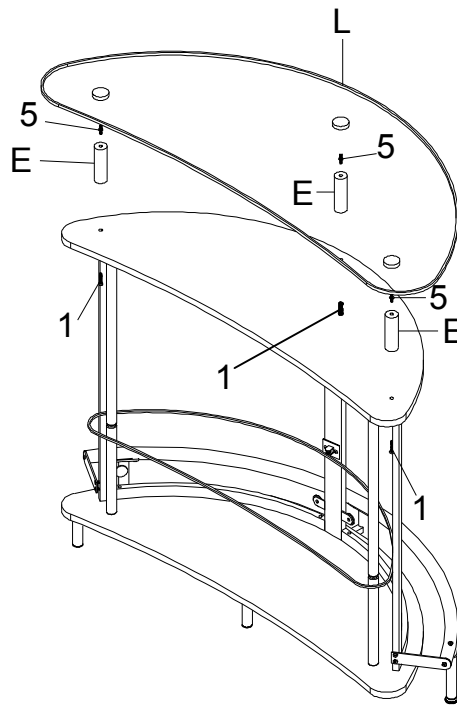

STEP 7  
COMPLETE

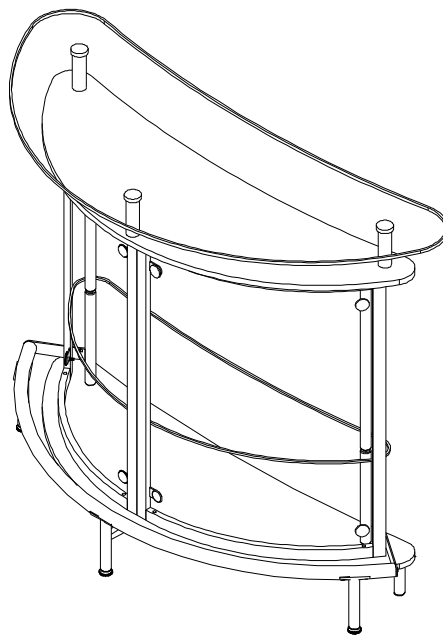

How to clean Acrylic product:  
Using a dry soft microfiber cloth, lightly brush off any dust.  
For additional care, dampen the cloth with warm water.  
For deepest cleaning, use an Acrylic cleaner.

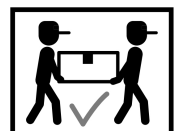

# ITEM:101065 ASSEMBLY INSTRUCTIONS



**Product Size : 1289 X 508 X 1041 H (MM)**

**Product Size : 50  $\frac{3}{4}$ " X 20" X 41"**

**The thickness of the metal is:1.0mm**

