

**ASSEMBLY INSTRUCTIONS**  
**INSTRUCCIONES**

**2723S-24 CHAIR**  
**2723S-24 SILLA**

No.	DESCRIPTION	Q'TY
A	CHAIR BACK SILLA DE LA	1pc/pieza
B	SEAT FRAME & CUSHION BASTIDOR DE ASIENTO	1pc/pieza
C	LEG PIERNA	2pcs/piezas
D	FRONT STRETCHER CAMILLA DELANTERA	1pc/pieza
E	LEFT SIDE STRETCHER CAMILLA LATERAL IZQUIERDA	1pc/pieza
F	RIGHT SIDE STRETCHER CAMILLA LATERAL DERECHA	1pc/pieza

No.	DESCRIPTION	Q'TY
①	SPRING WASHER ARANDELA $\odot$ 5/16"*13mm	11pcs/piezas
②	METAL WASHER ARANDELA DE PRESION $\odot$ 5/16"*19mm	11pcs/piezas
③	BOLT TORNILLO $\odot$ $\Phi$ 5/16"*18*1-3/4" (Chair Back Center)	3pcs/piezas
④	BOLT TORNILLO $\odot$ $\Phi$ 5/16"*18*2-3/8" (Front Leg)	4pcs/piezas
⑤	BOLT TORNILLO $\odot$ $\Phi$ 5/16"*18*3-1/4" (Chair Back Leg Corner)	4pcs/piezas
⑥	ALLEN KEY LLAVE L M5"*2-1/4"L	1pc/pieza
⑦	SCREW TORNILLO $\odot$ M3*1-1/2"	6pcs/piezas

step 1 / paso 1

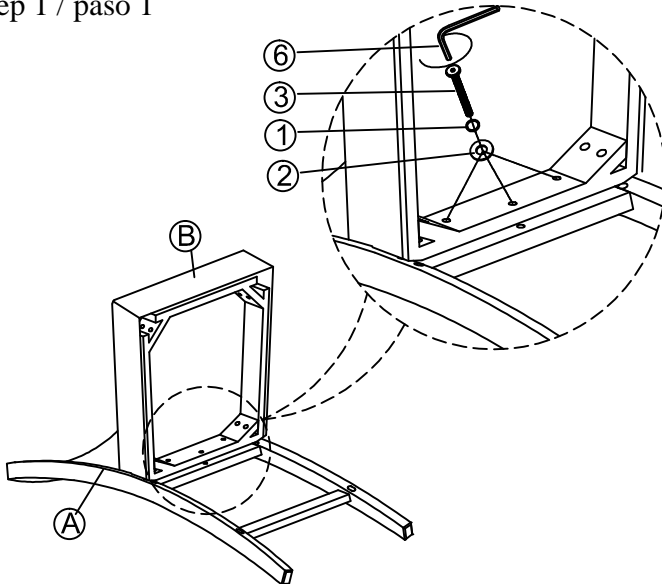

step 2 / paso 2

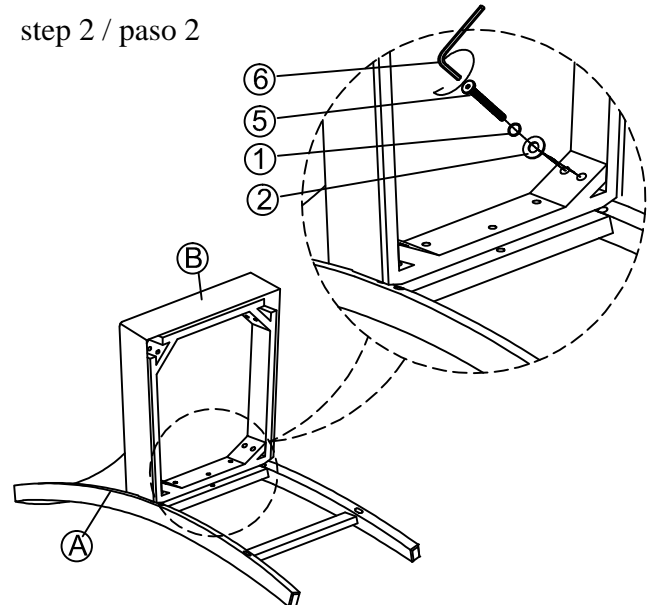

step 3 / paso 3

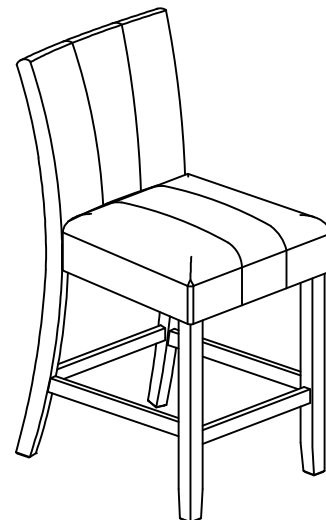
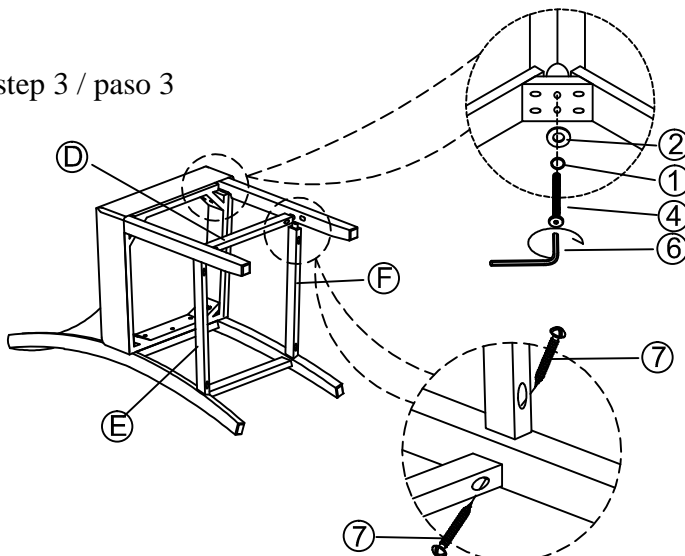

**DO NOT TIGHTEN SCREWS UNTIL COMPLETELY ASSEMBLED !**  
**NO APRETAR LOS TORNILLOS HASTA ARMAR COMPLETAMENTE**