







# ASSEMBLY INSTRUCTIONS

2222S CHAIR

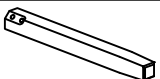
# INSTRUCCIONES

2222S SILLA

No.	DESCRIPTION	Q'TY
A	CHAIR BACK 	1pc/pieza
B	SEAT FRAME & CUSHION 	1pc/pieza
C	LEG 	2pcs/piezas

No.	DESCRIPTION	Q'TY
①	BOLT  $\Phi 5/16''-18 \times 1-3/4''L$ (Chair back center)	2pcs/piezas
②	BOLT  $\Phi 5/16''-18 \times 2-3/8''L$ (Front leg)	4pcs/piezas
③	BOLT  $\Phi 5/16''-18 \times 3-1/4''L$ (Chair back leg corner)	4pcs/piezas
④	ALLEN KEY  M5"×2-1/4"L	1pc/pieza

step 1 / paso 1

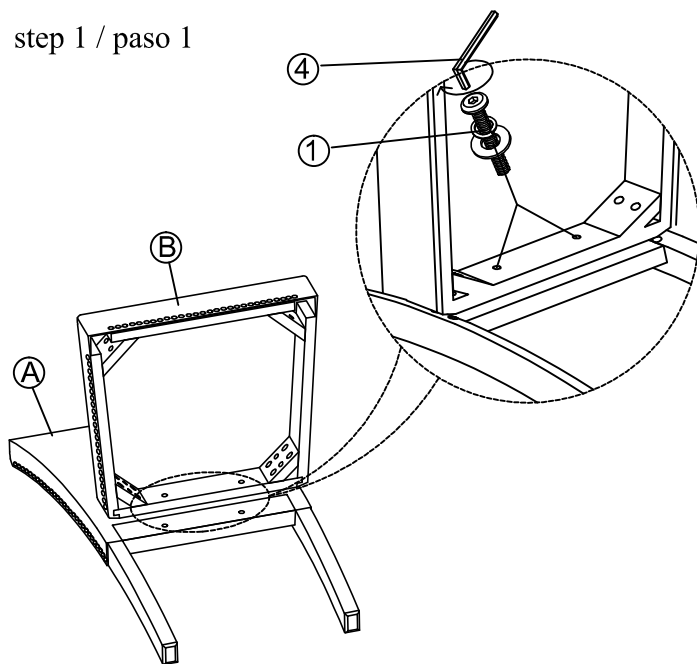

step 2 / paso 2

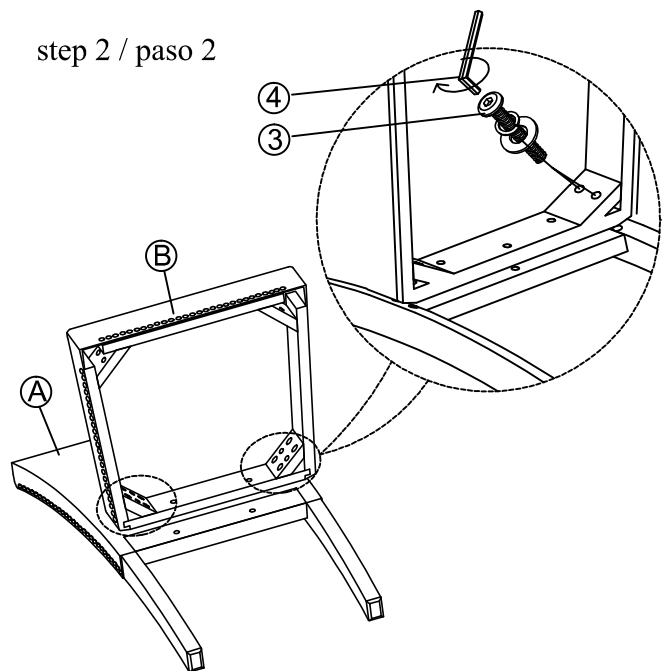

step 3 / paso 3

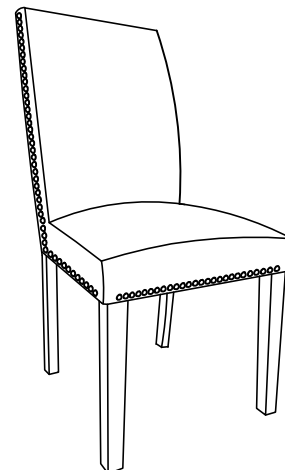
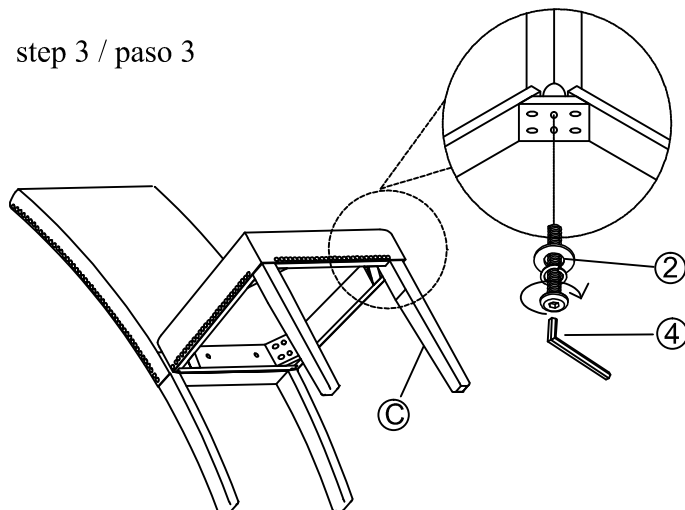

**DO NOT TIGHTEN SCREWS UNTIL COMPLETELY ASSEMBLED !**  
**NO APRETAR LOS TORNILLOS HASTA ARMAR COMPLETAMENTE**