

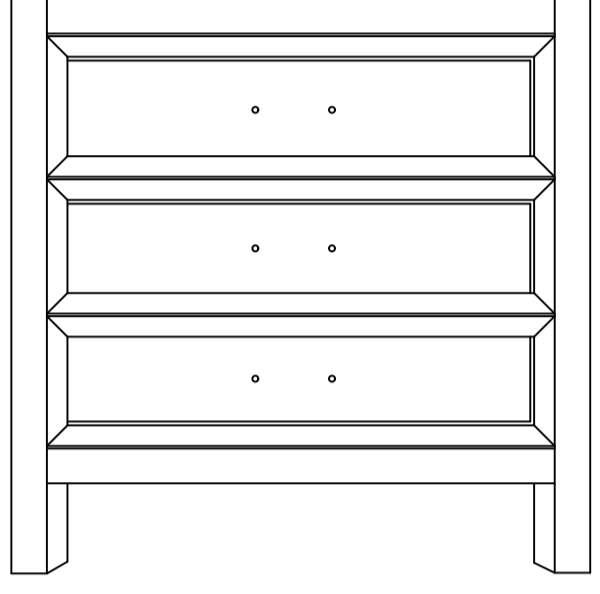

ASSEMBLY INSTRUCTIONS

CVFNR 5027

PARTS

HARDWARE

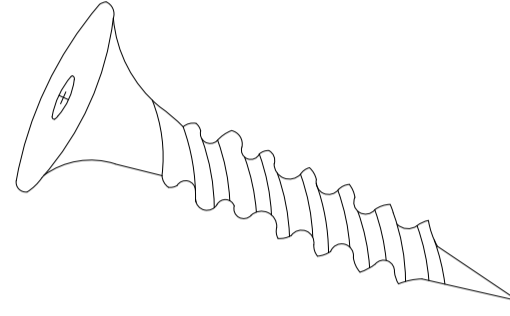
S.NO.	DESCRIPTION	QTY.
E	 BASE	1 Pc

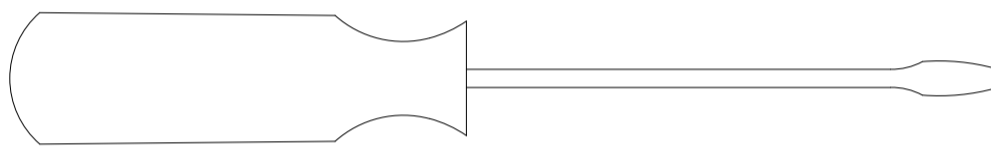
S.NO.	DESCRIPTION	QTY.
A	 SCREW	6 Pcs
B	 HANDLE	3 Pcs
C	 SCREW DRIVER	1 Pc

STEP-1

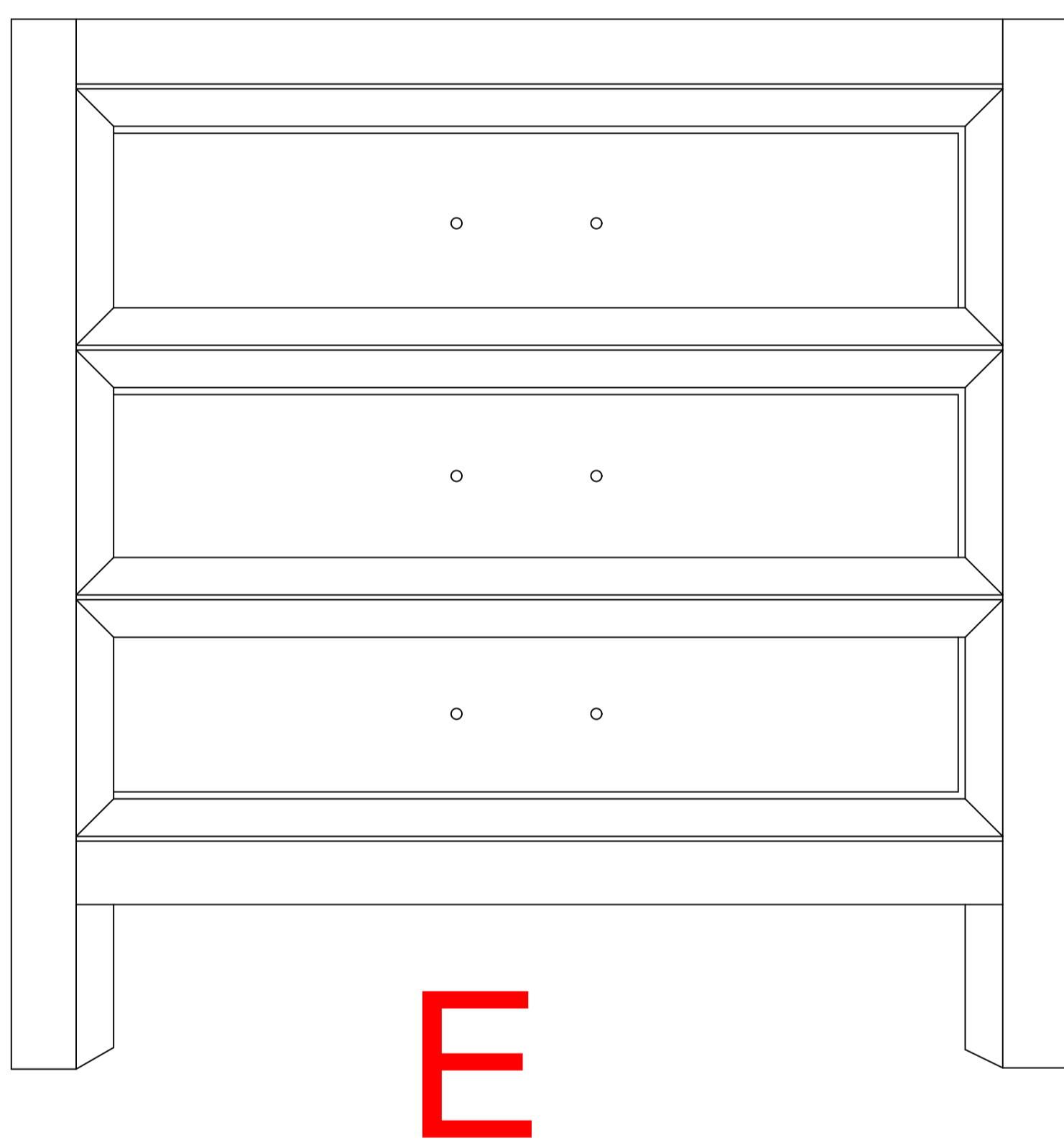

STEP-2

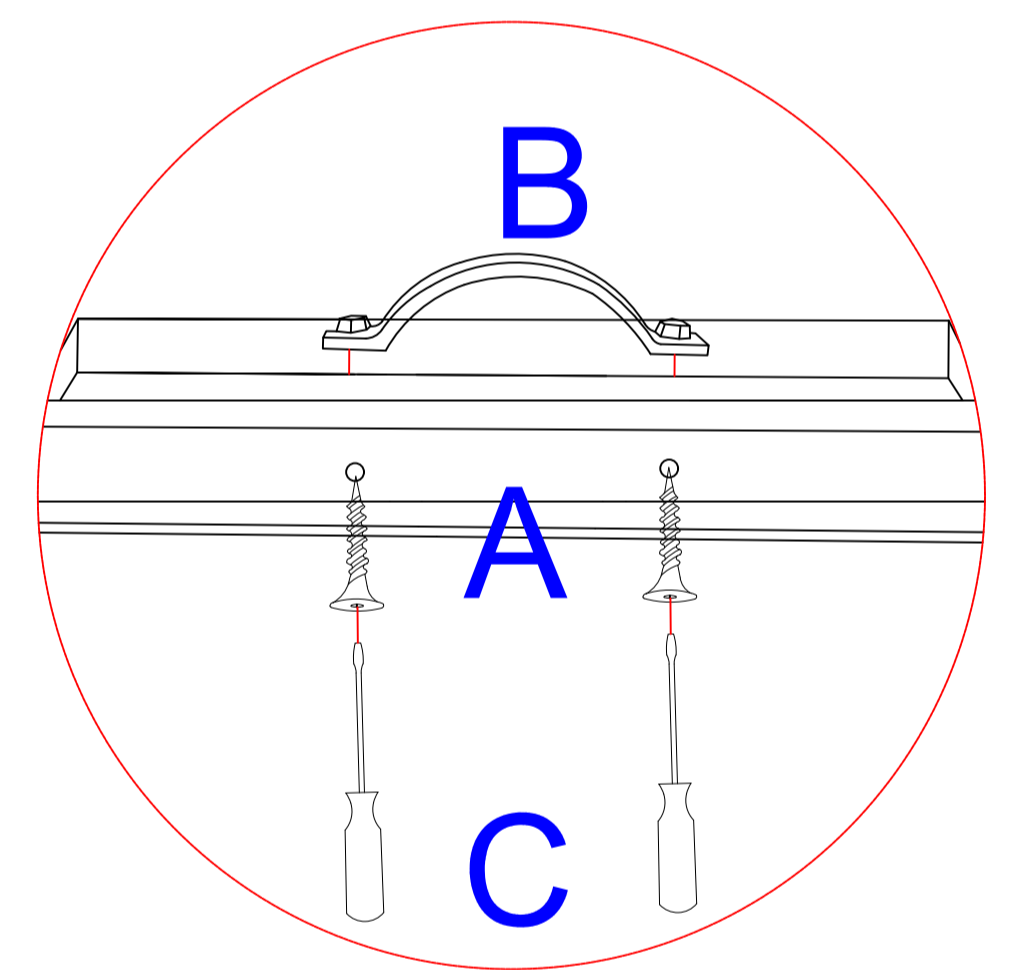
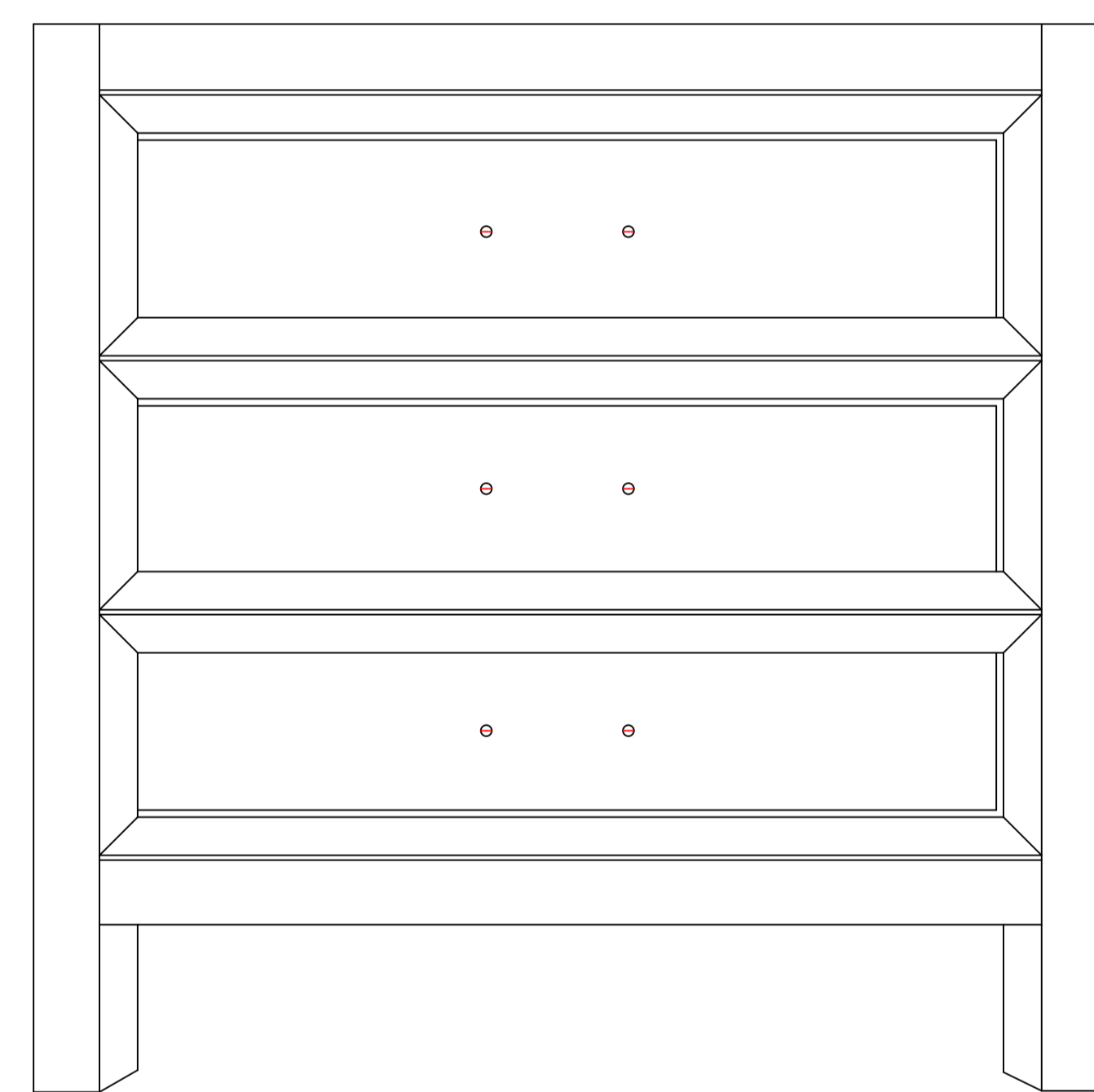

STEP-3

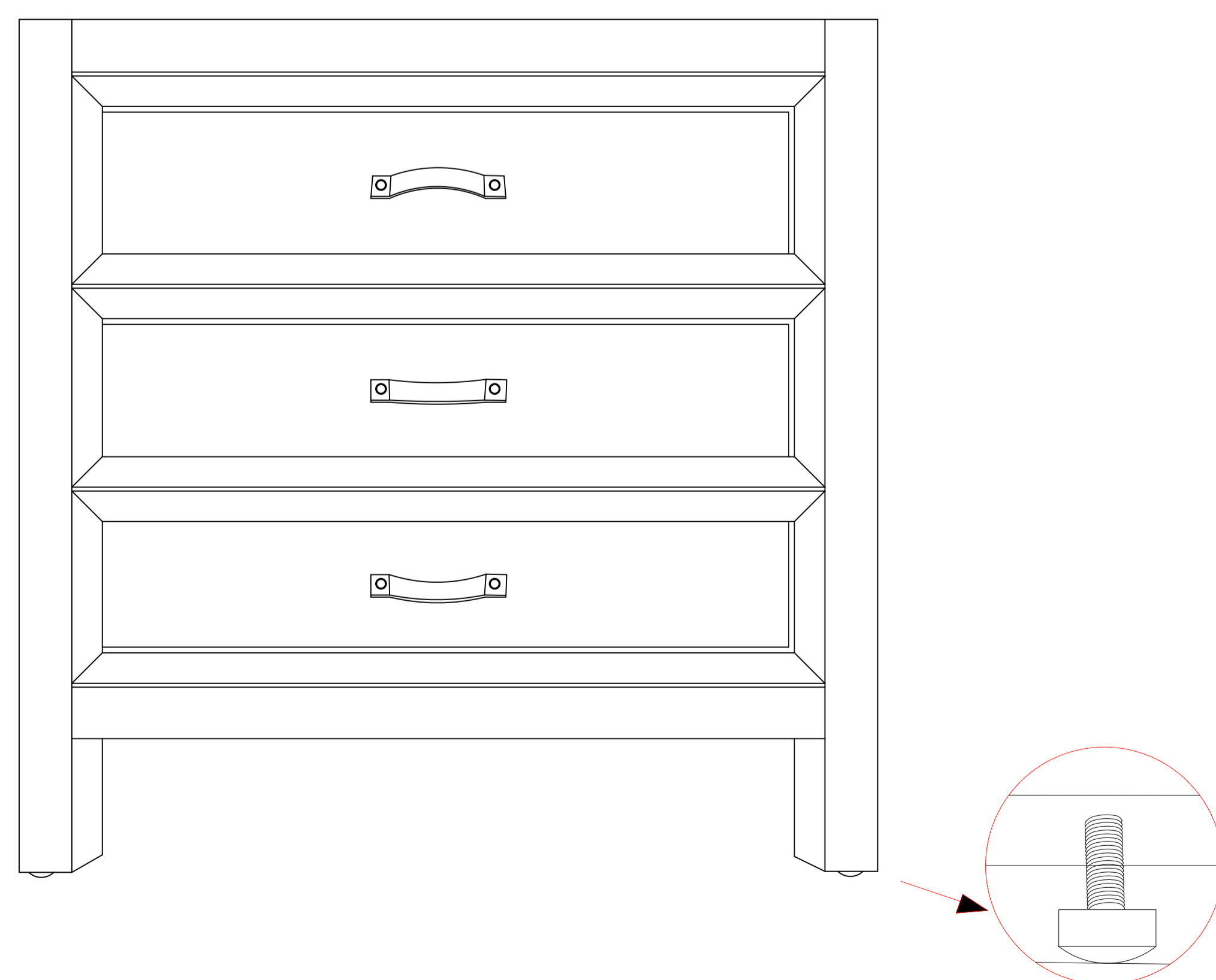

Note: Levellers are provided at bottom to balance the product on uneven surface.