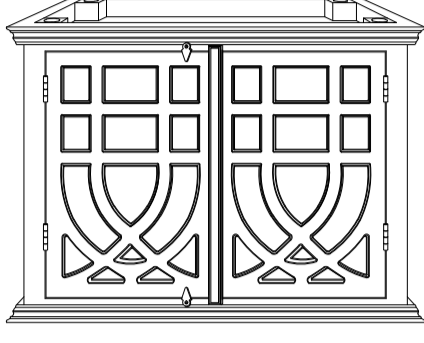
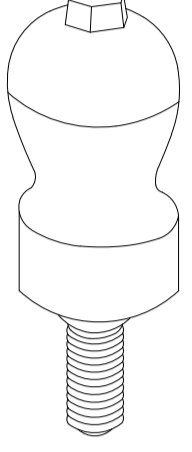

ASSEMBLY INSTRUCTIONS

CVFNR332

PARTS

HARDWARE

S.NO.	DESCRIPTION	QTY.
E	 BASE	1 Pc
F	 LEG F1/F2/F3/F4	4 Pcs

S.NO.	DESCRIPTION	QTY.
A	 HANDLE A1/A2	2 Pcs
B	 SCREW	12 Pcs
C	 SCREW DRIVER	1 Pc

STEP-1

E

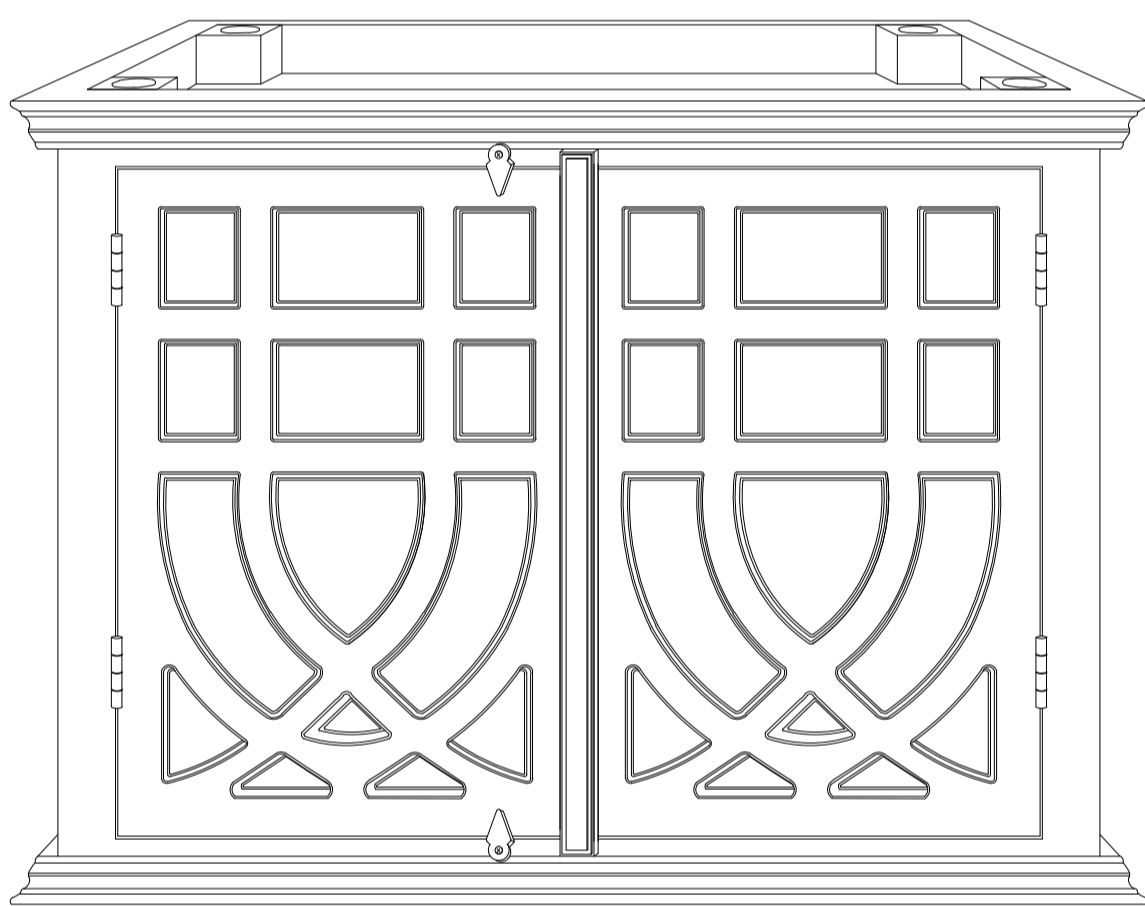

STEP-2

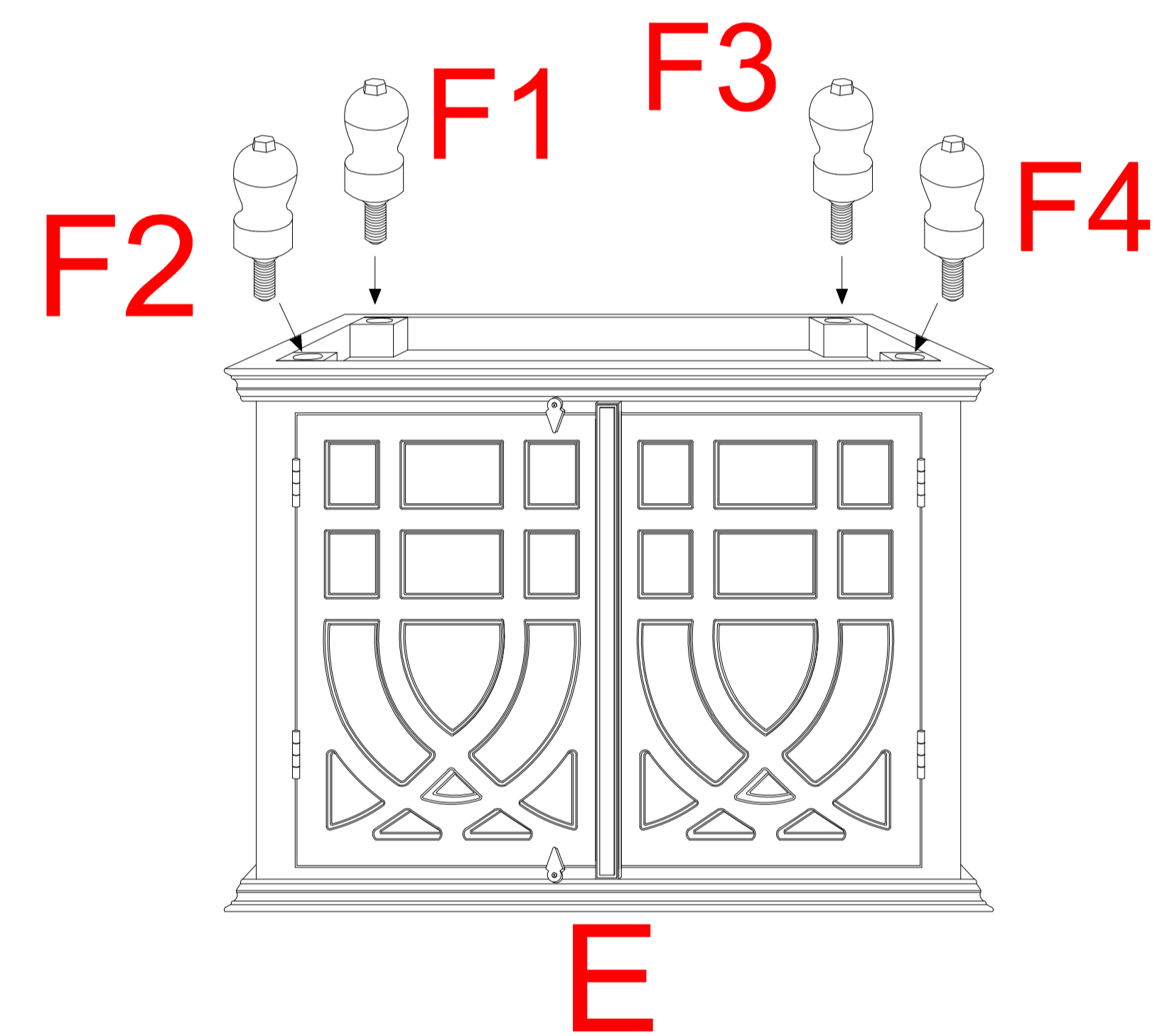

Note: Make sure that legs 100% screwed.

STEP-3

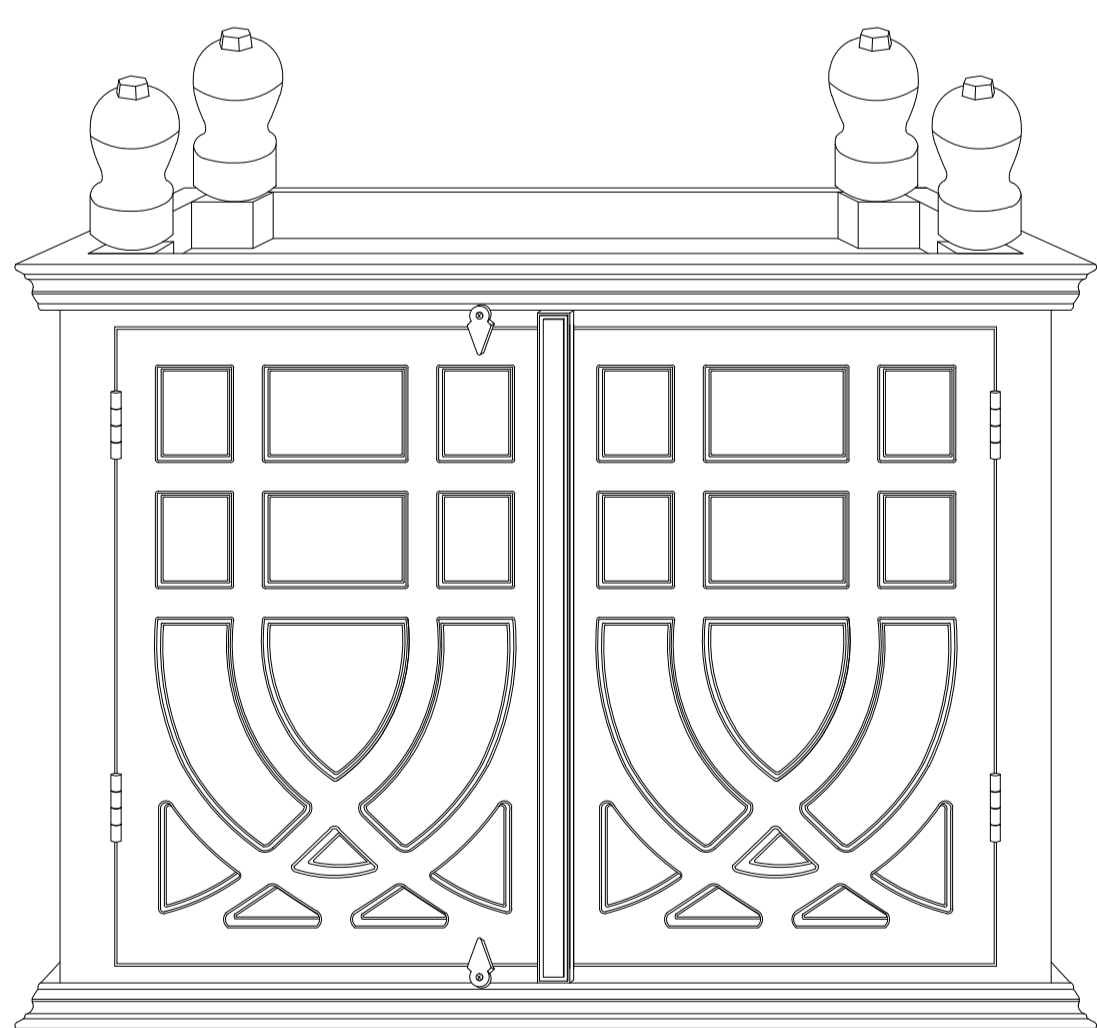

STEP-4

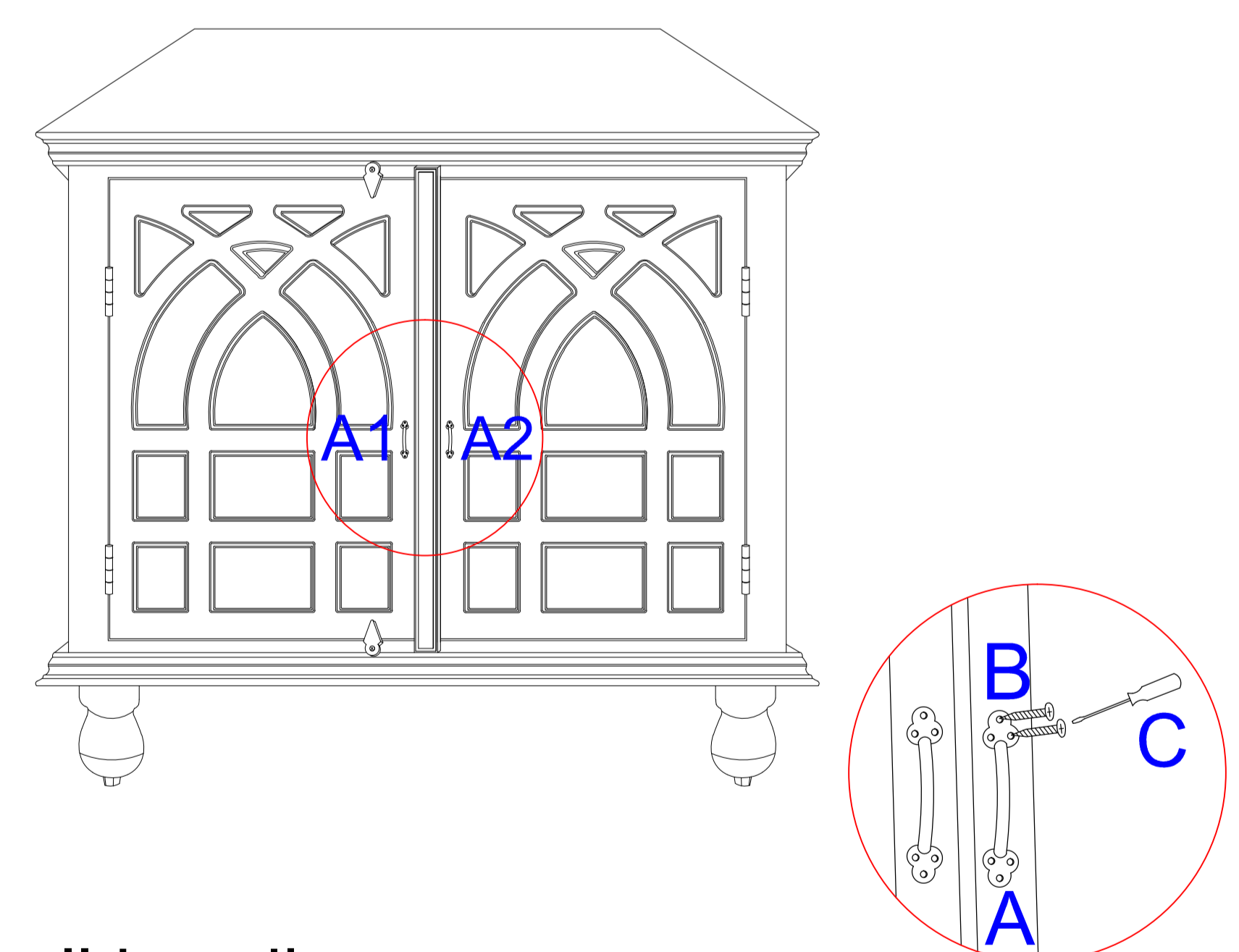

Note: Install all handles

STEP-5

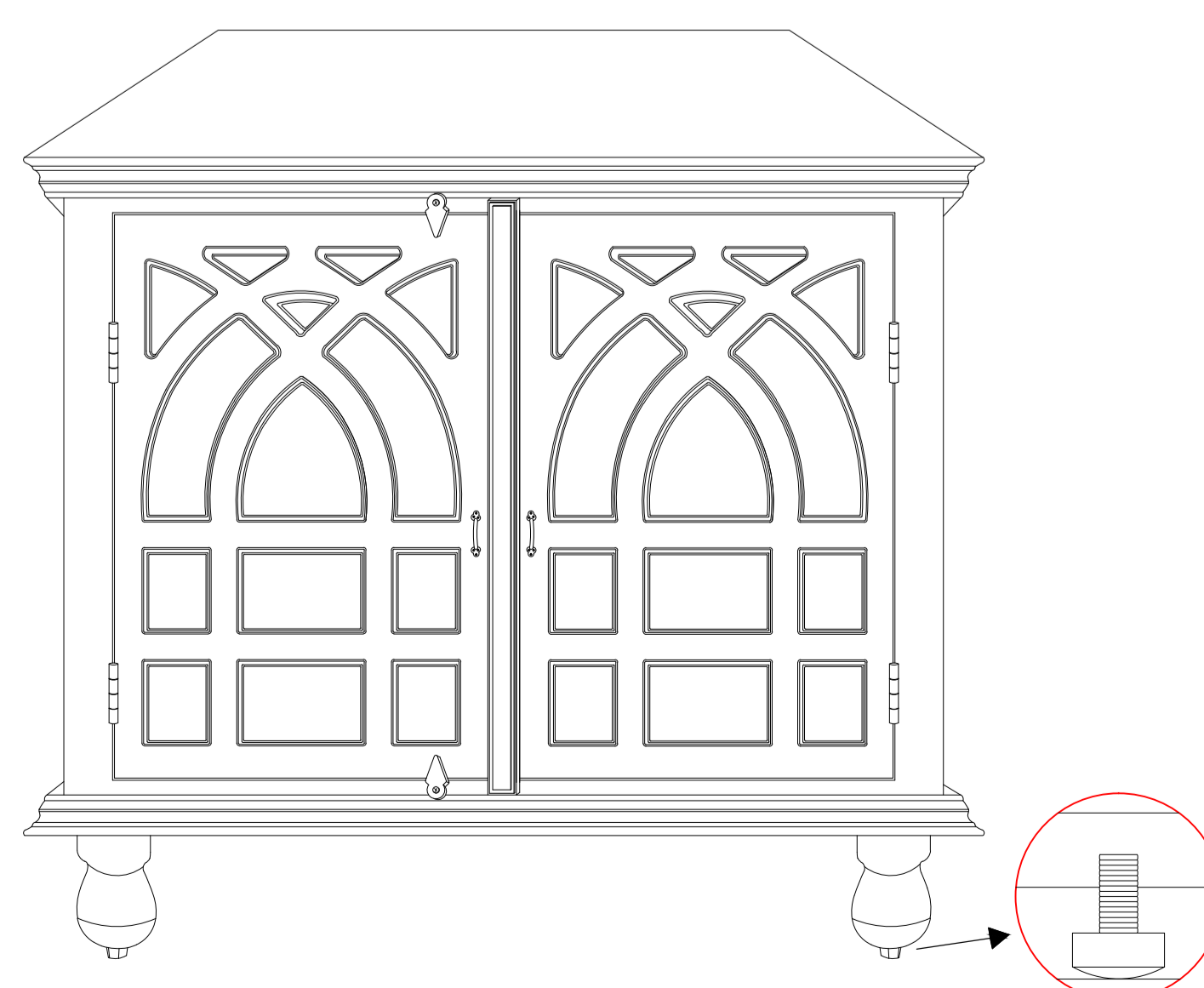

Note: Levellers are provided at bottom to balance the product on uneven surface.